

## STEAM TRAPS

**WFT Series**

## Float &amp; Thermostatic Steam Trap

Watson McDaniel reserves the right to change the designs and/or materials of its products without notice.  
©2010 Watson McDaniel Company

Model	<b>WFT</b>
Sizes	<b>3/4", 1", 1 1/4", 1 1/2", 2"</b>
Connections	<b>NPT</b>
Body Material	<b>Cast Iron</b>
PMO Max. Operating Pressure	<b>250 PSIG</b>
TMO Max. Operating Temperature	<b>Saturated Steam Temperature</b>
PMA Max. Allowable Pressure	<b>250 PSIG up to 450°F</b>
TMA Max. Allowable Temperature	<b>450°F @ 250 PSIG</b>



**WFT  
3/4" & 1"**



**WFT  
2"**



**WFT  
1 1/4" & 1 1/2"**

## TYPICAL APPLICATIONS

**PROCESS:** The **WFT Series** float and thermostatic steam traps are used for HVAC and industrial process applications. The excellent air handling capabilities of these traps make them a better choice than bucket traps for applications requiring quick start-up. Used on unit heaters, textile machines, heat exchangers, and other process equipment.

## HOW IT WORKS

Float and thermostatic steam traps have a float and thermostatic element that work together to remove both condensate and air from the steam system. The valve, which is attached to a float, rises and opens the valve when condensate enters the trap. Air is discharged through the thermostatic air vent to the outlet side of the trap. The thermostatic air vent closes when steam enters the trap.

## FEATURES

- All stainless steel internals with hardened seat and wear parts
- In-line repairability is simplified by having all internals attached to the cover
- Welded stainless steel thermostatic air vent resists shock from water hammer. Live orifice air vent is available for superheated applications
- Excellent air handling capability allowing air to be discharged rapidly and steam to enter the system quickly during start-up
- F & T traps discharge condensate immediately as it is formed (no condensate will back-up into the system)

## SAMPLE SPECIFICATION

The trap shall be of float and thermostatic design with cast iron body and in-line piping configuration. Thermostatic air vent to be welded stainless steel. All internals must be stainless steel with hardened seat area. Trap must be in-line repairable.

## INSTALLATION

Isolation valves should be installed with trap to facilitate maintenance. The trap must be level and upright for the float mechanism to operate. Trap must be sized and located properly in the steam system.

## MAINTENANCE

Close isolation valves prior to performing any maintenance. All internal components can be replaced with the trap body remaining in-line. Repair kits include thermostatic air vent, float, valve seat and disc, and gaskets. For full maintenance details see Installation and Maintenance Manual.

## OPTIONS

Live orifice air vent for superheated steam applications.

## WFT Series

Float & Thermostatic Steam Trap

Dimensions: inches

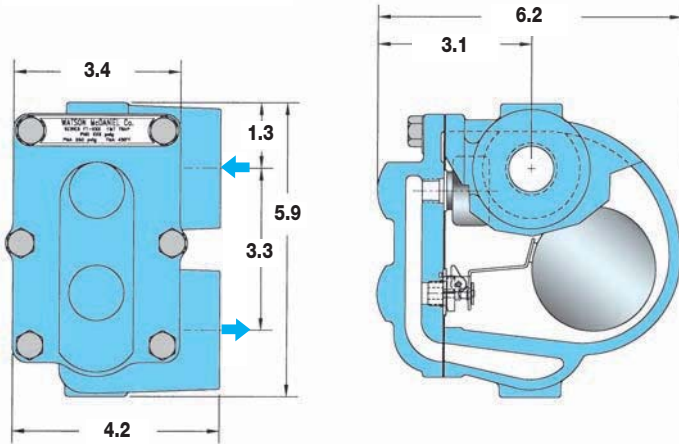

### SPECIFICATIONS

Model	Sizes	Connection	PMO (PSIG)	PMA (PSIG)	Weight (lbs)
WFT-15	3/4", 1", 1 1/4"	NPT	15	125	9
WFT-30	3/4", 1", 1 1/4"	NPT	30	125	9
WFT-75	3/4", 1"	NPT	75	125	9
WFT-125	3/4", 1"	NPT	125	125	9

Dimensions: inches

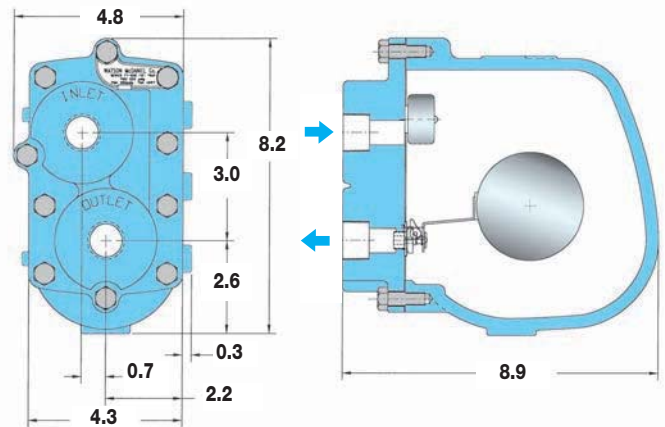

### SPECIFICATIONS

Model	Sizes	Connection	PMO (PSIG)	PMA (PSIG)	Weight (lbs)
WFT-175	3/4", 1", 1 1/4"	NPT	175	250	20
WFT-250	3/4", 1", 1 1/4"	NPT	250	250	20

Dimensions: inches

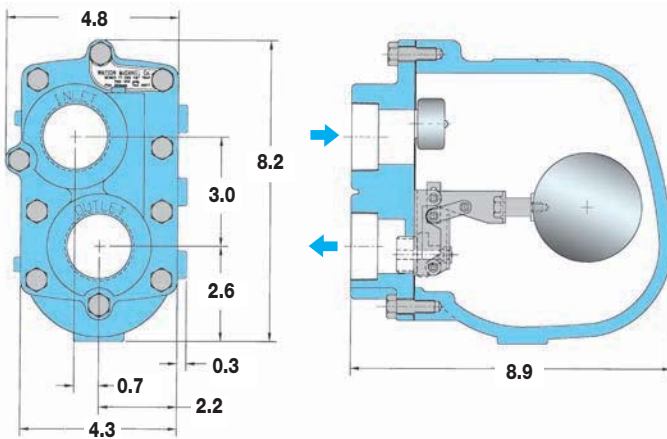

### SPECIFICATIONS

Model	Sizes	Connection	PMO (PSIG)	PMA (PSIG)	Weight (lbs)
WFT-15	1 1/2"	NPT	15	250	21
WFT-30	1 1/2"	NPT	30	250	21
WFT-75	1 1/4", 1 1/2"	NPT	75	250	21
WFT-125	1 1/4", 1 1/2"	NPT	125	250	21
WFT-175	1 1/4", 1 1/2"	NPT	175	250	21
WFT-250	1 1/4", 1 1/2"	NPT	250	250	21

Dimensions: inches

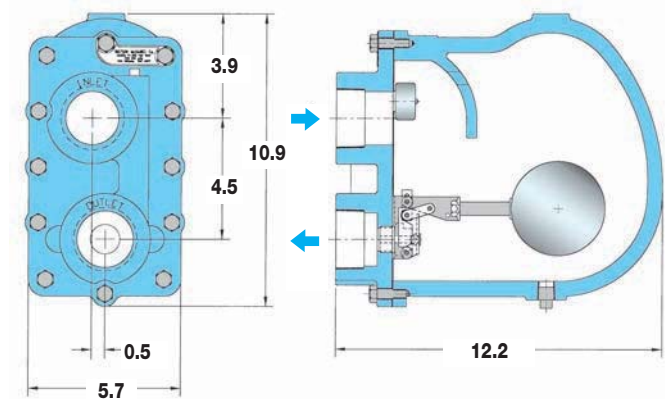

### SPECIFICATIONS

Model	Sizes	Connection	PMO (PSIG)	PMA (PSIG)	Weight (lbs)
WFT-15	2"	NPT	15	250	53
WFT-30	2"	NPT	30	250	53
WFT-75	2"	NPT	75	250	53
WFT-125	2"	NPT	125	250	53
WFT-175	2"	NPT	175	250	53
WFT-250	2"	NPT	250	250	53

# STEAM TRAPS

## WFT Series

### Float & Thermostatic Steam Trap

Watson McDaniel reserves the right to change the designs and/or materials of its products without notice.  
©2010 Watson McDaniel Company

#### MATERIALS

Body & Cover	Cast Iron
Gasket	Grafoil
Cover Screws	Steel, GR5
Float	Stainless Steel, AISI 304
Internals	Stainless Steel, 300 Series
Thermostat	Stainless Steel
Valve Seat	Stainless Steel, 17-4 PH
Valve Disc	Stainless Steel, AISI 420F

#### HOW TO SIZE/ORDER

From the capacity chart, select the model that can handle the working pressure of the system (PMO). Select the trap that will meet the capacity requirements at the differential pressure. Example:

Application: 1,910 lbs/hr at 30 PSIG working pressure and 1/2 PSI differential pressure

Size/Model: 2" WFT-030-17, 0.500" Orifice, NPT connections

#### CAPACITIES – Condensate (lbs/hr)

Model	PMO (PSIG)	Pipe Size	Orifice Size	Differential Pressure (PSI)																				
				1/4	1/2	1	2	5	10	15	20	30	40	50	75	100	125	150	175	200	225	250		
WFT-015-13	15	3/4"	0.250	390	490	620	780	1050	1320	1500														
WFT-015-14	15	1"	0.250	390	490	620	780	1050	1320	1500														
WFT-015-15	15	1 1/4"	0.312	610	770	960	1210	1630	2040	2330														
WFT-015-16	15	1 1/2"	0.500	1420	1910	2570	3460	5120	6890	8190														
WFT-015-17	15	2"	0.625	2260	2950	3860	5040	7170	9360	10930														
WFT-030-13	30	3/4"	0.228	330	420	530	670	930	1180	1350	1500	1720												
WFT-030-14	30	1"	0.228	330	420	530	670	930	1180	1350	1500	1720												
WFT-030-15	30	1 1/4"	0.228	330	420	530	670	930	1180	1350	1500	1720												
WFT-030-16	30	1 1/2"	0.390	930	1240	1650	2190	3210	4280	5060	5700	6750												
WFT-030-17	30	2"	0.500	1420	1910	2570	3460	5120	6890	8190	9260	11020												
WFT-075-13	75	3/4"	0.166	175	225	295	385	545	705	825	920	1075	1200	1305	1525									
WFT-075-14	75	1"	0.166	175	225	295	385	545	705	825	920	1075	1200	1305	1525									
WFT-075-15	75	1 1/4"	0.312	640	850	1130	1500	2180	2900	3420	3850	4540	5110	5600	6610									
WFT-075-16	75	1 1/2"	0.312	640	850	1130	1500	2180	2900	3420	3850	4540	5110	5600	6610									
WFT-075-17	75	2"	0.422	1020	1340	1760	2310	3330	4380	5140	5760	6770	7590	8290	9730									
WFT-125-13	125	3/4"	0.128	105	135	180	235	340	445	525	585	690	770	845	990	1110	1210							
WFT-125-14	125	1"	0.128	105	135	180	235	340	445	525	585	690	770	845	990	1110	1210							
WFT-125-15	125	1 1/4"	0.250	410	540	710	930	1340	1770	2070	2320	2730	3050	3340	3920	4390	4790							
WFT-125-16	125	1 1/2"	0.250	410	540	710	930	1340	1770	2070	2320	2730	3050	3340	3920	4390	4790							
WFT-125-17	125	2"	0.332	720	960	1270	1690	2460	3270	3860	4340	5130	5770	6320	7460	8390	9190							
WFT-175-13	175	3/4"	0.166	190	250	320	420	590	770	900	1010	1180	1310	1430	1670	1870	2030	2180	2310					
WFT-175-14	175	1"	0.166	190	250	320	420	590	770	900	1010	1180	1310	1430	1670	1870	2030	2180	2310					
WFT-175-15	175	1 1/4"	0.250	410	540	710	930	1340	1770	2070	2320	2730	3050	3340	3920	4390	4790	5150	5470					
WFT-175-16	175	1 1/2"	0.250	410	540	710	930	1340	1770	2070	2320	2730	3050	3340	3920	4390	4790	5150	5470					
WFT-175-17	175	2"	0.281	520	680	900	1180	1700	2230	2620	2930	3440	3860	4210	4950	5540	6050	6510	6920					
WFT-250-13	250	3/4"	0.128	115	145	190	245	345	450	520	580	675	755	820	955	1060	1155	1235	1310	1375	1440	1495		
WFT-250-14	250	1"	0.128	115	145	190	245	345	450	520	580	675	755	820	955	1060	1155	1235	1310	1375	1440	1495		
WFT-250-15	250	1 1/4"	0.203	270	350	450	590	820	1070	1240	1380	1600	1780	1940	2250	2500	2720	2910	3080	3240	3380	3520		
WFT-250-16	250	1 1/2"	0.203	270	350	450	590	820	1070	1240	1380	1600	1780	1940	2250	2500	2720	2910	3080	3240	3380	3520		
WFT-250-17	250	2"	0.250	410	540	710	930	1340	1760	2060	2310	2710	3040	3320	3890	4360	4760	5110	5430	5730	6000	6250		