



Pulse Point™ Series models sense when a material reaches or leaves a particular point. These point level switches use electronic vibratory technology to sense the material, which is a mechanical principle and is not affected by the dielectric constant of the material being measured.

The LP-2000 Model does not require calibration, saving time and resources for an easy, quick installation. With build-up detection, various fork options and a universal power supply, the Bindicator® LP-2000 can provide a solution to meet your needs in many materials and applications.

FEATURES AND BENEFITS

- Liquid/solid interface for materials submerged in liquid
- Lights quickly show condition of system
- To save time, testing can be done without removing cover
- Less susceptible to vibration for harsh conditions
- Dual tines prevent rat holing for dependable measurements
- Remote configuration available

Optional 90° SS Fork

Commonly used in hopper, funnel area to sense material or lack of during filling processes; can also be mounted on the side of a vessel to allow forks to be pointing downward if top mounting not an option.

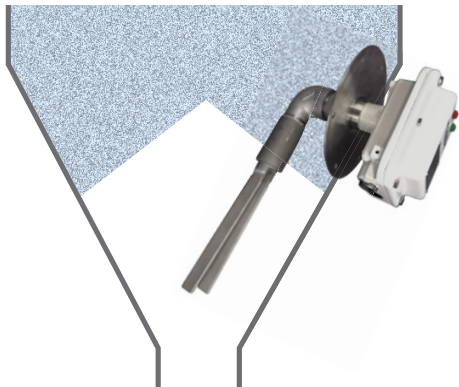

Unit is not proportional to silo size.

APPLICATIONS

General	Light weight or heavily aerated powders
	Granular solids
	Materials that do not coat or build up
Food	Beans, Nuts, Seeds
	Salt, Flour, Grains, Powdered Milk
	Spices, Animal Foods, Tobacco
Chemicals	Carbon Black
	Styrofoam, Plastics, Rubber
	Clays, Chalk
Construction	Sand
	Wood Chips, Sawdust, Cellulose
	Paper Products, Glass
	Cement, Flyash

PULSE POINT™ LP-2000

MOUNTING OPTIONS INTEGRAL & PIPE EXTENDED UNITS

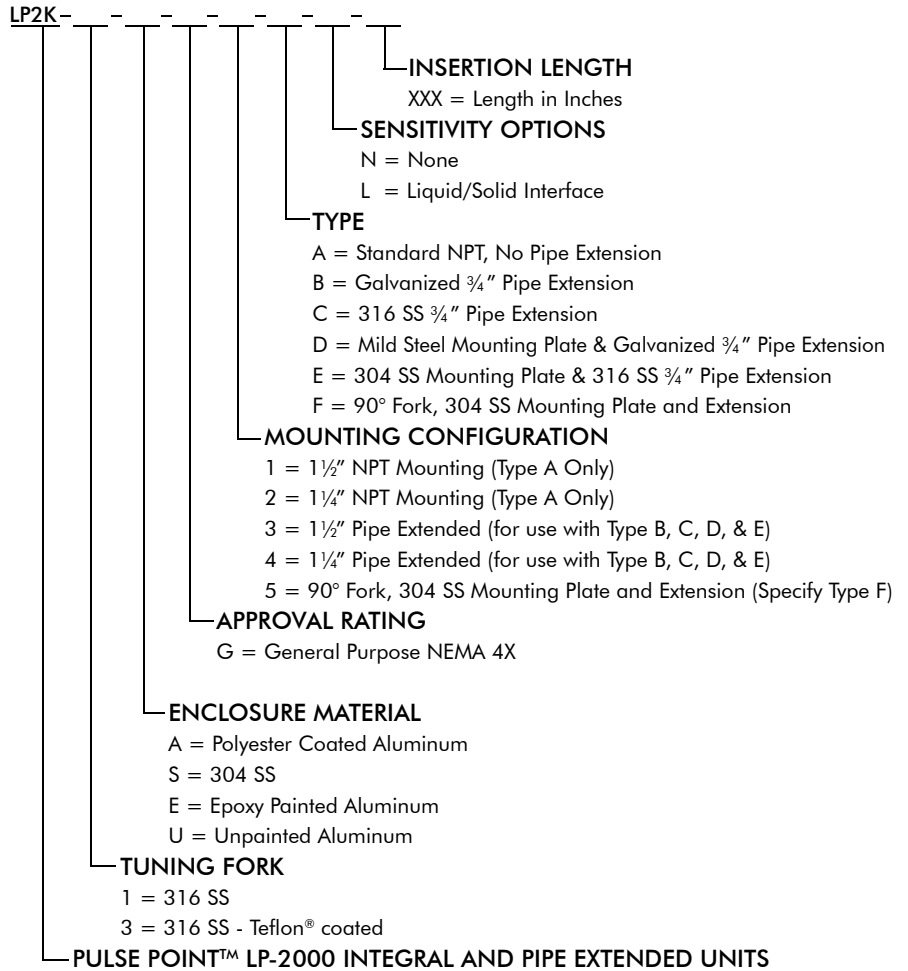
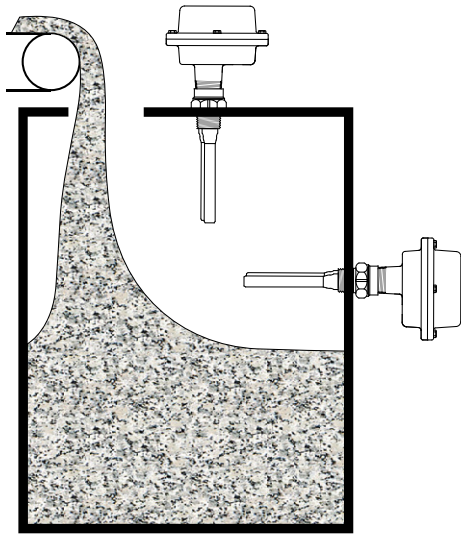

MOUNTING TYPE

Mounting Type	Maximum Insertion Length
A	NA
B	180 in
C	180 in
D	180 in
E	180 in
F	40 in

DIMENSIONS - STANDARD UNIT

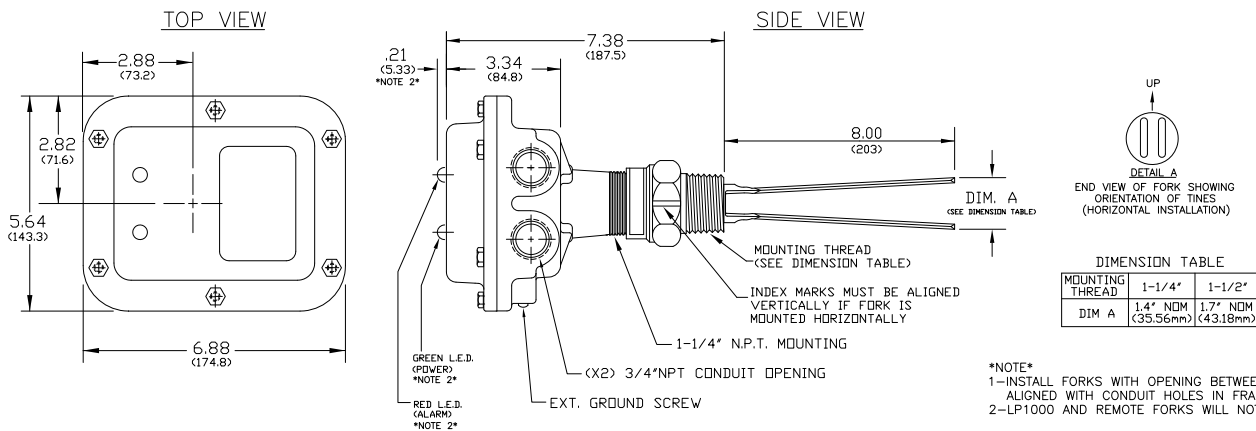

ADDITIONAL DIMENSION DRAWINGS

See Pulse Point™ LP-2000 Installation & Operation Manual or visit www.bindicator.com/LPSeries

REMOTE MOUNT ELECTRONICS

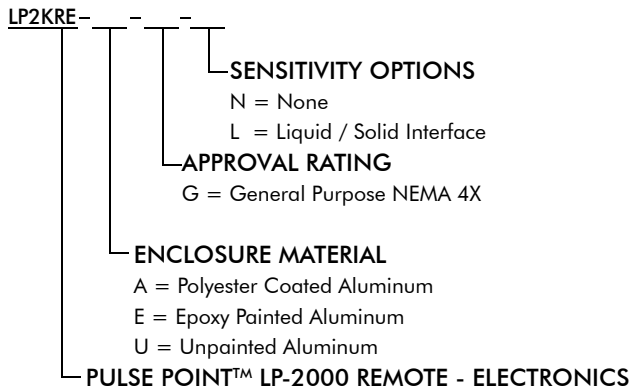

REMOTE DIMENSIONS

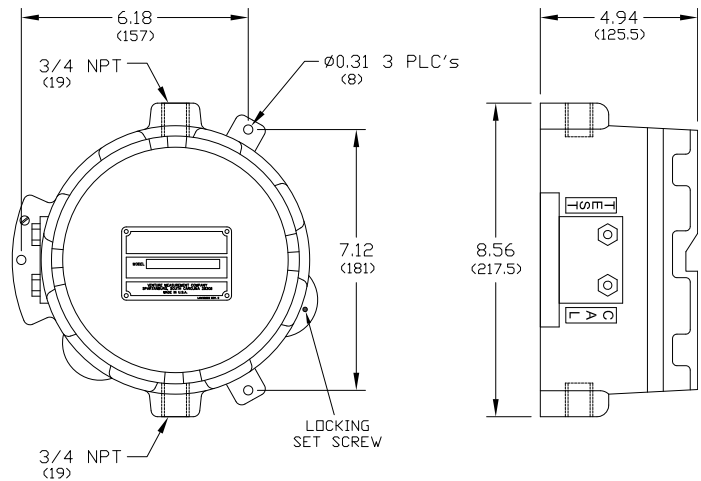

REMOTE PROBE TUNING FORKS

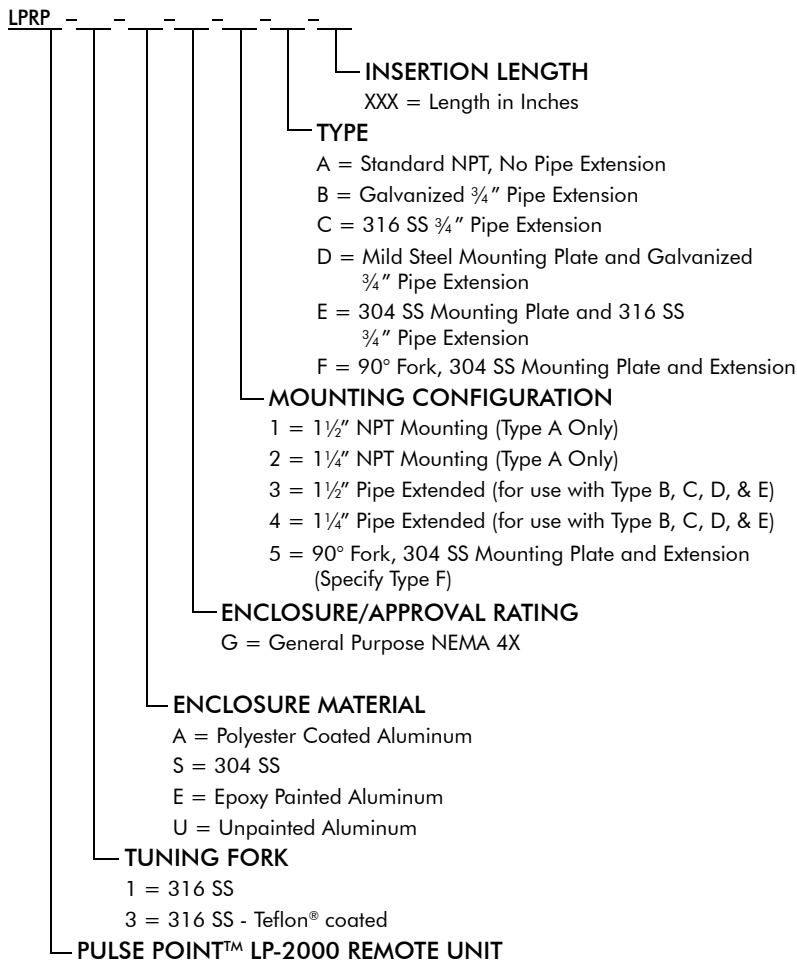

OPTIONAL REMOTE UNIT CONFIGURATIONS

For high temperature applications, a remote unit can be installed to limit direct contact with the unit. The remote unit cannot be mounted more than 100 feet away.



AGENCY APPROVALS

CE

- Electromagnetic Compatibility
- Low Voltage Directive 2006/95/EC

SPECIFICATIONS

FUNCTIONAL	
Power Requirements	Universal, (+/- 10%) 100-240 VAC 50/60 Hz or 22-65 VDC
Power Consumption	11 W AC; 4 W DC
Operating Temperature Electronics Tuning Fork	-40° to 158° F (-40° to 70° C) -55° to 302° F (-48° to 150° C)
Outputs Main Relay Auxillary Relay	8A DPDT @ 277 VAC or 30 VDC (resistive) 0.46 @ 150 VAC or 1A SPDT @ 30 VDC
PERFORMANCE	
Pressure Rating	150 psi (10.5 kg/cm ²) with 1 1/2" NPT; 5 psi (0.35 kg/cm ²) with mounting plate
Time Delay	Field Adjustable; 1-150 seconds
Fail Safe	Field Selectable high/low level
Sensitivity	Minimum 0.5 lbs/ft ³ (8 kg/m ³); Field Adjustable
Maximum Particle Size	3/8" (9.5 mm)
PHYSICAL	
Dual Conduit Entry	3/4" NPT
Process Connections	1 1/4" or 1 1/2" NPT; Extended forks can be mounted directly through 1 1/4" or 1 1/2" NPT half coupling
Maximum Insertion Length	15 ft (4.6m)
Shipping Weight	Integral, non-extended 10 lb (4.5 kg)
OPTIONS	
Remote Electronics	
Mounting Plates	8" Diameter; Various materials
Flanges	2 to 4"; Various materials

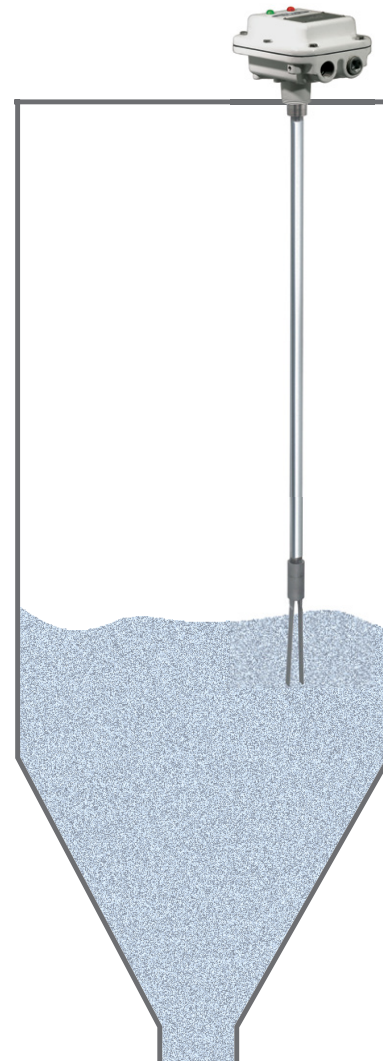

Optional Pipe Extension

When only top mounting is available, the pipe extension can be used to reach the desired depth in order to be in contact with material.

Unit is not proportional to silo size.



150 Venture Boulevard · Spartanburg, SC 29306
Tel: (800) 778-9242 · (864) 574-8060
Fax: (864) 574-8063
E-mail: sales@bindicator.com
www.bindicator.com

venture
MEASUREMENT

LVP180450 Rev. B

2012 All rights reserved.
All data subject to change without notice.