

# AE1800/1800R Series

Air Eliminator

Model	AE1800, AE1800R
Sizes	1/2", 3/4"
Connections	NPT
Body Material	Stainless Steel
PMO Max. Operating Pressure	400 PSIG
TMO Max. Operating Temperature	500°F
PMA Max. Allowable Pressure	400 PSIG up to 500°F
TMA Max. Allowable Temperature	500°F @ 400 PSIG



AE1800  
(Non-Repairable)



AE1800R  
(Repairable)

## TYPICAL APPLICATION

The **AE1800** Air Eliminator is used for the removal of air and other gases from vessels or piping systems without allowing the contained liquid to escape.

## HOW IT WORKS

The valve and seat assembly inside the air eliminator is connected to a stainless steel float. When there is no liquid in the body of the air eliminator, the float will be in the down position allowing air or other gases in the vessel or piping system to escape. When liquid enters the body, it will lift the float and the valve will be closed off before any liquid can escape.

## FEATURES

- All stainless steel body & internals
- Hardened SST seat (55 Rc) for longer service life
- Repairable units available (AE1800R Series)

## INSTALLATION & MAINTENANCE

The AE1800 should be located at a high point in the system or vessel. The unit must be installed level and upright with flow upward for the float mechanism to operate properly. Isolation valves should be installed for ease of maintenance.

## DIMENSIONS – inches / pounds

Model & Orifice Size			Size (Inlet x Outlet)	Height A	Weight (lbs)
.078"	.101"	.125"			
AE1811	AE1821	AE1831	3/4" x 1/2"	7.5	4
AE1811R	AE1821R	AE1831R		7.9	5
AE1812	AE1822	AE1832		3/4" x 3/4"	7.5
AE1812R	AE1822R	AE1832R	7.9		5
AE1813	AE1823	AE1833	1/2" x 1/2"		7.5
AE1813R	AE1823R	AE1833R		7.9	5

## CAPACITIES – Air (SCFM)

Series	Orifice Size	PMO* (PSIG)	Inlet Pressure (PSIG)																						
			5	7	9	12	15	20	25	30	40	50	60	70	80	90	100	110	120	125	150	180	265	300	400
AE1810	.078"	400	1.0	1.1	1.3	1.5	1.7	1.9	2.2	2.5	3.1	3.4	3.7	4.2	5.4	6.0	6.8	7.2	7.5	7.9	9.4	11.2	16.3	18.4	24.4
AE1820	.101"	265	1.7	1.9	2.1	2.4	2.6	3.1	3.5	4.0	4.8	5.3	5.7	6.6	8.4	9.3	10.2	11.1	12	12.4	14.5	17.3	24.8	-	-
AE1830	.125"	180	2.5	3.0	3.4	3.9	4.3	5.1	5.8	6.5	8.0	8.7	9.5	10.9	13.9	15.4	16.9	18.4	19.9	20.5	24.4	29.6	-	-	-

Note: Specify Model Number when ordering. Example: **AE1812R** (.078" Orifice, 3/4" x 3/4", 400 PSIG max, Repairable unit)

\* PMO based on liquids with specific gravity of 1. Consult factory for PMO for liquids of other specific gravity values.

## MATERIALS

Body & Shell	Stainless Steel, AISI 304
Float Assembly	Stainless Steel, AISI 304
Valve & Lever Assembly	Hardened Stainless Steel, 55 Rc
Seat	Stainless Steel, AISI 420
Washer, Seat	302 SS
*Gasket	Grafoil
*Bolt, Hex, HD	Stainless Steel, AISI 316
*Nut	Stainless Steel, 18-8

\* AE1800R Repairable models only.

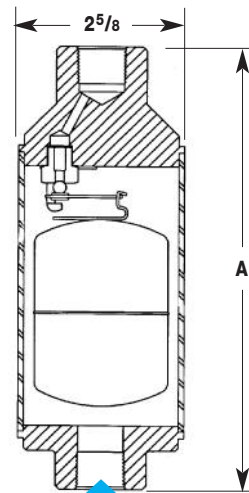

AE1800  
(Non-Repairable)

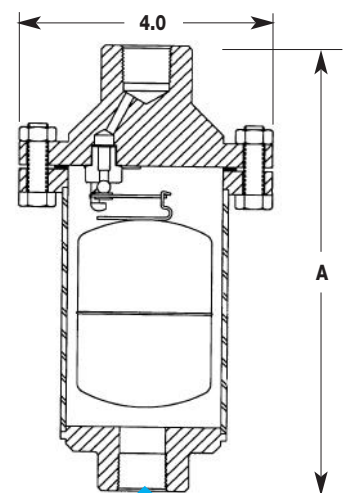

AE1800R  
(Repairable)

SPECIALTY  
PRODUCTS