



Portable Carts

- Portable wheeled carts come furnished with a flow-efficient, built-in 4" manifold
- Wheels feature pneumatic tires and wheel locks
- The monitors have stop positions at 45° on either side of center and 25° above horizontal.
- Cart specific highlights include:
 - The two wheel cart attaches with a 1 7/8" or 2" coupler (*please specify*); to the vehicle for extra stability during flow; two hose beds each capable of holding 100' of 2 1/2" or 3" hose
 - The four wheel cart has a detachable "tee" handle, optional hose racks above the wheels — each capable of holding a 50' "donut roll" of 2 1/2" hose, and an optional 1 1/2" gated outlet
- Liquid-filled pressure gauge

5-61

Pneumatic tires
and wheel locks

Red urethane
finished

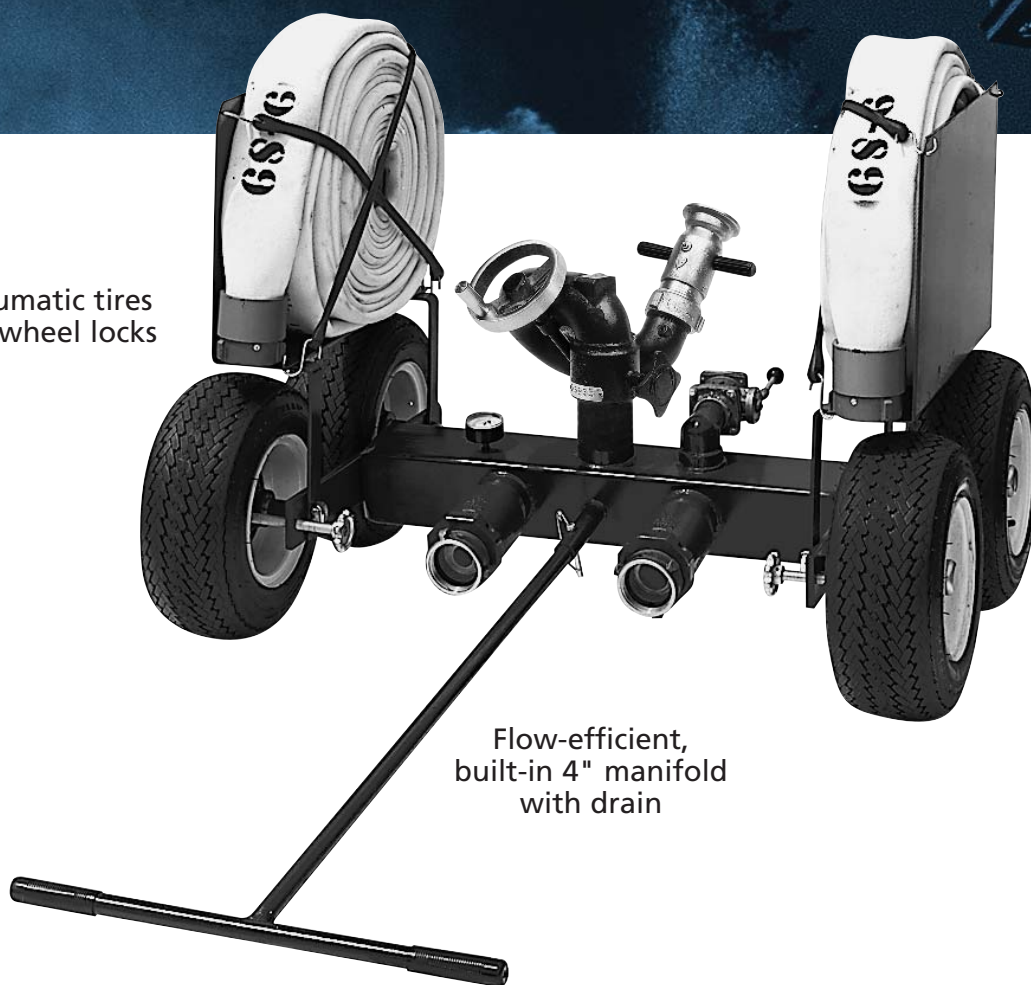

Flow-efficient,
built-in 4" manifold
with drain

1000
GPM

SPECIFICATIONS			
Max. GPM (LPM)	1000 (3785) (See table for specifics)		
Inlet Sizes/Types	2 x 2.5" NHT (F)		
	Optional Additional Cart Inlets		
	1 x 5" Storz		
	1 x 4" Storz		
	2 x 2.5" NHT (F) (Swivel)		
Outlet Size	2.5" NHT		
Controls	Single hand-wheel		
	Tiller		
Material/Finish	Brass with red urethane enamel		
Friction Loss	GPM	Stingray® Carts (8393)	Python® Carts (299-11)
	1000	56 psi	35 psi
	750	34 psi	20 psi
	500	12 psi	9 psi
Travel	V Variable (see chart for specifics)		
	H L45° to R45° (90°)		
Weight	See selection chart for specifics		
Ratings and Certifications			

KEY CONFIGURATIONS (ACCESSORIES)

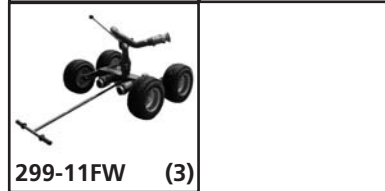
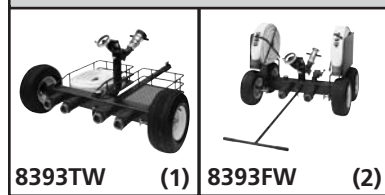

ADDITIONAL INFORMATION

- These monitor types are also available in monitor only and hydrant versions.
- Please see page 5-23 for Stingray® (8393 series) details or page 5-39 for Python® (299-11 series) versions.
- When flowing 1000 gpm, the cart must be attached to vehicle for safety.

Portable Cart Selector Guide

Cart Type/ GPM (LPM)	Monitor	INLET OPTIONS				OUT-LET	CART FEATURES							VERTICAL TRAVEL		CONTROLS				DIMENSIONS (Inches)			Weight (Lbs.)	ILLUSTRATION	MODEL
		2 x 2.5" NHT*	2 x 2.5" NHT* +4" Storz	2 x 2.5" NHT* +5" Storz	4 x 2.5" NHT*		2.5" NHT	T Handle	1.875" Hitch	2" Hitch	1.5" NHT Manifold Outlet	Pressure Gauge	Hose Beds	Hose Racks**	+20° to 70° (50°)	+20° to 90° (70°)	Single Hand-wheel	Steering Wheel	Tiller Bar	Width	Depth	Height			
2-Wheel/ 1000 (3785)	Stingray® 8393	s	o	o	o	•		s	o	o	s	s		•		s			67.00	72.00	34.00	310.0	1	8393TW	
	Python® 299-11	s	o	o	o	•		s	o	o	o	s		•		o	s		44.00	68.00	23.75	307.5		299-11TW	
4-Wheel/ 750 (2839)	Stingray® 8393	s	o	o	o	•	s			o	s		o	•	s			67.00	72.00	34.00	230.0	2	8393FW		
	Python® 299-11	s	o	o	o	•	s			o	o		o	•	o	s		44.00	68.00	23.75	227.5	3	299-11FW		
											1	2												Illustration	

KEY s = standard o = option
 * Clappered female swivel inlets.
 ** This feature will change the height of the end product.

Recommended Products

SM-1000HF – SELF-EDUCTING	CSW-C-HF – SELF-EDUCTING	IMS-500 – SELECT-O-STREAM®	J – MYSTERY®	181 – DELUGE TIP	282B – STREAM SHAPER
Page 6-14	Page 6-14	Page 6-10	Page 6-12	Page 1-29	Page 1-27