



4 Turnkey State-Of-The-Art Systems to Improve Operating Efficiencies in Plastic Extrusion Equipment

Designed for Durability, Ease of Installation and Trouble-Free Service . . .

These highly engineered heating and cooling systems are an innovative concept in product design, offering a very efficient means to heat and cool the barrels of plastic extruders. They provide cooling efficiencies equal to or better than conventional liquid cooled cast-in aluminum band heaters.

These shroud designs are made with stainless steel sheet metal, cast aluminum, or an aluminum sheet metal/cast aluminum hybrid construction.

These systems are self-contained and can be supplied as turnkey ready-to-go, requiring minimum labor and installation cost, and drastically reducing downtime and maintenance upkeep compared to conventional liquid cooling and heating cast-in band heaters.

Experience all the advantages offered by Tempco's exclusive Cool TO-THE Touch High-Efficiency shroud and aluminum finned cast-in band heater designed system.





The engineering of these two components is perfectly matched to work in tandem, offering thermally efficient heating and air cooling characteristics and eliminating the shortcomings of liquid cool cast-in aluminum band heaters

Improve Efficiencies in Extrusion Processing.

Need Assistance Selecting a System? We Welcome Your Inquiries.

If you have a special application requiring a custom manufactured system or need assistance selecting one of our standard systems for a new or existing installation, consult Tempco with your requirements. We offer complete engineering services and support, working with you every step of the way, to ensure customer satisfaction.

Selection Guide — Plastic Extruder Heating and Cooling Shroud Design Systems

Shroud Style Construction	Recommended Heater Types	Barrel Diameter Range		Zone Length Range	
		Min.	Max.	Min.	Max.
 <p>1 Cool TO-THE Touch™, Page 3-23 Inner Stainless Steel Solid Layer; Outer Stainless Steel Perforated Layer</p>	Tempco Finned Cast Aluminum Heaters, Vented Ceramic Band or Maxiband Heaters	3" 76 mm	16" 406 mm	5" 127mm	30-1/2" 775 mm
 <p>2 Multi-Versal, Page 3-29 Single Stainless Steel Solid Layer</p>	Tempco Finned Cast Aluminum Heaters, Vented Ceramic Band or Maxiband Heaters	3" 76 mm	16" 406 mm	3-3/4" 95 mm	30-1/2" 775 mm
 <p>3 Polar Cast, Page 3-36 Inner Stainless Steel Solid Layer; Outer Cast Aluminum Vented Layer</p>	Tempco Finned Cast Aluminum Heaters	4" 102 mm	16" 406 mm	8" 203 mm	30-1/2" 775 mm
 <p>4 Arctic Cast®, Page 3-39 Single Cast Aluminum Solid Layer</p>	Tempco Finned Cast Aluminum Heaters	4" 102 mm	16" 406 mm	6-1/2" 165 mm	30-1/2" 775 mm



Arctic Cast® Extruder Heat/Cool System

Our pioneer product in cast shroud designs, Tempco's Arctic Cast shroud systems provide vast improvements over standard water cooled castings for durability and performance. The Arctic Cast shroud features a vented 1/4" thick cast aluminum layer. The cast-in heaters are designed with a large fin surface area to maximize cooling efficiency. The blower port directs inlet air to

the hottest part of the heater, distributing it evenly over the entire cross section of the zone. The cooling efficiency of Tempco's Arctic Cast shroud system meets or exceeds that of water-cooled systems when used with our field proven high capacity blowers.

4 – Arctic Cast Construction

Arctic Cast Extruder

Single Layer Shroud – Vented Cast Aluminum layer bolted directly onto Tempco's Specially Designed Finned Cast-In Aluminum Band Heater

Usage Requirements

This rugged shroud design is recommended for installations where the shroud system could be exposed to physical damage, such as instances where the extruder barrel is low to the ground. It is suited to work with Tempco's Specially Designed Finned Cast-In Aluminum Heater and cannot be used on any existing finned cast-in heaters.

Ordering Information

See Page 3-42 for complete Ordering Information.

Arctic Cast Construction Details

Single Layer Shroud

- * Vented 1/4" thick Cast Aluminum layer – directs the cooling air flow over the heater

Shroud Assembly Features

- * Two Individual Halves bolted together (Two-Piece) and clamped directly to finned cast heater
- * Blower Options – See Pages 3-43 through 3-45 for complete details
 - Single or Dual Tempco Recommended Blowers available from 148 CFM up to 1210 CFM at 115V or 230V
 - Customer Specified blower
- * Blower Location
 - Vertical Orientation – at the bottom of the shroud
 - Custom location achieved only by rotating entire shroud system
- * Standard top Air Outlet
 - Custom location achieved only by rotating entire shroud system
- * Shroud Air-Inlet Baffle with built-in air deflector that breaks up incoming airflow, distributing it across the cast-in heater(s)



Arctic Cast shown with Dual Blower Mount Option

Heater Type and Components

- * Recommended Heater Types – Tempco Finned Cast-In Heaters with standard 1/4" gap between heater halves and bolt and nut clamping
- * Heater Strap Clamping is available
- * Power Input with Standard 10-32 stud termination with ceramic or mica insulator
 - Bus Wiring between halves is optional

Sensing and Controlling

- * Existing Zone Control Probe – Shroud System can be designed per customer specifications
- * Tempco supplied Zone Control Probe
- * Tempco customized Power Control Panel designed to complete Your Thermal Loop System



Selecting Standard (Non-Stock) Arctic-Cast® System Assembly

Extruder Size	Heater I.D. in	Assy. No. Shroud & Heater	Watts Each Half	Volts Each Half	Replacement Components		Dimensions			Shroud Style
					Heater	Shroud	"A" in	"B" in	"L" in	
2" to 2½"	4.500	FCS01001	1620	230	CBH02937	ASF01006	9.000	8.500	10.750	A
	4.500	FCS01002	1500	230	CBH05676	ASF01052	7.750	5.375	12.250	C
	5.000	FCS01003	2000	230	CBH05677	ASF01053	9.000	6.313	12.438	C
	5.500	FCS01004	2750	230	CBH03270	ASF01001	10.000	9.125	11.000	A
	4.725	FCS01005	1400	240	CBH03960	ASF01015	8.188	6.299	7.402	A
	4.940	FCS01006	2250	230	CBH05539	ASF01046	8.940	10.625	12.000	A
	5.500	FCS01007	2100	230	CBH02803	ASF01002	10.000	9.125	11.000	A
	5.500	FCS01008	1700	230	CBH02909	ASF01007	10.000	9.125	8.500	A
	5.500	FCS01009	4150	230	CBH03664	ASF01009	10.000	10.125	13.250	A
	5.500	FCS01010	1725	230	CBH04193	ASF01020	9.000	7.063	9.000	A
	5.750	FCS01011	2700	230	CBH05404	ASF01037	10.250	11.250	13.000	A
3½"	6.250	FCS01012	1400	260	CBH05153	ASF01029	10.250	7.688	8.250	A
	6.250	FCS01013	5000	480	CBH05648	ASF01051	10.500	10.125	15.000	A
	6.500	FCS01014	3600	230	CBH02802	ASF01003	11.000	9.750	17.500	A
	6.500	FCS01015	3000	240	CBH03699	ASF01010	10.500	9.375	12.000	A
	6.500	FCS01016	3000	240	CBH03700	ASF01011	10.500	10.125	15.000	A
	6.500	FCS01017	3600	230	CBH02802	ASF01014	11.000	9.750	17.500	A
	6.500	FCS01018	3750	230	CBH04953	ASF01026	10.500	10.500	13.000	A
	6.500	FCS01019	3600	230	CBH02802	ASF01050	11.000	9.750	17.500	A
	6.625	FCS01020	4625	480	CBH03606	ASF01008	11.000	9.750	17.500	A
	6.750	FCS01021	4800	230	CBH05405	ASF01038	11.250	11.250	16.000	A
	4"	7.500	FCS01022	6000	240	CBH04815	ASF01025	11.500	10.000	21.000
7.500		FCS01023	4500	240	CBH05092	ASF01028	11.500	10.000	18.000	A
7.500		FCS01024	3500	230	CBH05395	ASF01035	12.000	11.250	17.000	A
7.500		FCS01025	6000	230	CBH05396	ASF01036	12.000	11.250	22.000	A
7.500		FCS01026	4170	230	CBH05397	ASF01036	12.000	11.250	22.000	A
7.500		FCS01027	4170	230	CBH05573	ASF01047	12.000	12.250	22.000	A
7.500		FCS01028	6000	230	CBH05575	ASF01047	12.000	12.250	22.000	A
7.500		FCS01029	3500	230	CBH05574	ASF01048	12.000	12.250	18.000	A
7.625		FCS01030	5500	230	CBH04732	ASF01024	11.500	8.375	14.438	A
8.000		FCS01031	3250	230	CBH03738	ASF01013	12.000	8.438	14.000	A
8.250		FCS01032	3850	230	CBH03994	ASF01019	12.250	9.000	13.000	A
8.250		FCS01033	7000	190	CBH04426	ASF01021	12.250	11.430	16.000	A
8.500		FCS01034	5750	240	CBH05234	ASF01030	12.500	10.500	20.000	B
8.250		FCS01035	7000	480	CBH04629	ASF01012	13.000	10.500	19.000	A
8.500		FCS01036	7200	240	CBH03711	ASF01012	13.000	10.500	19.000	A
8.660	FCS01037	3000	230	CBH03508	ASF01004	13.125	10.875	8.000	A	
8.660	FCS01038	3000	230	CBH03508	ASF01005	13.125	10.875	16.000	A	
6"	9.313	FCS01039	7500	230	CBH05326	ASF01033	13.813	14.500	23.500	A
	9.313	FCS01040	9900	230	CBH05327	ASF01033	13.813	14.500	23.500	A
	9.313	FCS01041	7500	230	CBH05328	ASF01034	13.813	14.500	28.500	A
	9.313	FCS01042	7500	230	CBH05445	ASF01039	13.813	14.500	23.500	A
	9.313	FCS01043	9900	230	CBH05446	ASF01039	13.813	14.500	23.500	A
	9.313	FCS01044	7500	230	CBH05447	ASF01040	13.813	14.500	28.500	A
	9.313	FCS01045	9900	460	CBH05513	ASF01042	13.813	14.500	28.500	A
	9.313	FCS01046	7500	460	CBH05515	ASF01043	13.813	14.500	23.500	A
	9.750	FCS01047	9000	110	CBH04428	ASF01022	13.750	12.125	22.000	A
	9.750	FCS01048	9000	190	CBH04427	ASF01022	13.750	12.125	22.000	A
	9.750	FCS01049	5700	480	CBH05530	ASF01044	13.750	11.125	15.500	A
	9.750	FCS01050	5700	480	CBH05531	ASF01045	13.750	11.125	21.500	A
	9.750	FCS01051	5250	240	CBH05619	ASF01049	13.750	12.125	22.000	A
	9.750	FCS01052	7500	480	CBH05684	ASF01054	13.750	11.125	19.000	A
	9.750	FCS01053	7500	480	CBH05685	ASF01055	13.750	11.125	19.000	A
10.000	FCS01054	7850	240	CBH04996	ASF01027	14.000	11.250	24.500	B	
10.630	FCS01055	3450	240	CBH05238	ASF01031	16.875	14.065	29.000	B	
8"	11.000	FCS01056	11000	110	CBH04429	ASF01023	15.000	12.750	22.000	A
	13.000	FCS01057	6750	480	CBH05289	ASF01032	17.000	12.000	14.000	A

The typical Arctic Cast System consists of: A Cast-In Aluminum Finned Band Heater
A Cast Aluminum Shroud
An appropriately rated Forced Air Blower



Note: For additional information on sizing and selecting Cast-In Band Heaters for your application, see page 3-39. To order an Arctic-Cast system not shown in our Standard Sizes and Ratings, consult Tempco or send us your specifications and/or drawing.

Page 3-37 illustrates the system complete as well as the components that make up each assembly. Envelope dimensions for the shrouds shown on page 3-39 are also provided. Pages 3-40 and 3-41 display different forced air blower styles and specifications.



Selection of Arctic Cast® Shroud Design Styles

Shroud Style A

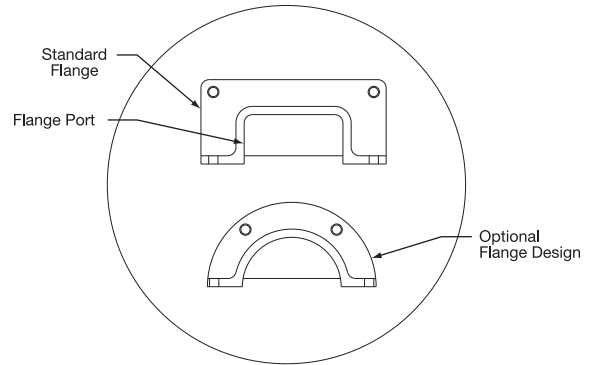
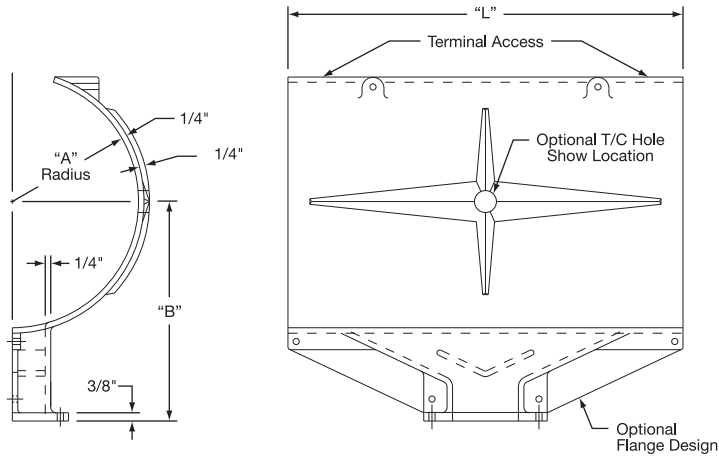

Please provide mounting hole specifications if using other than Tempco standard.

Shroud Style B

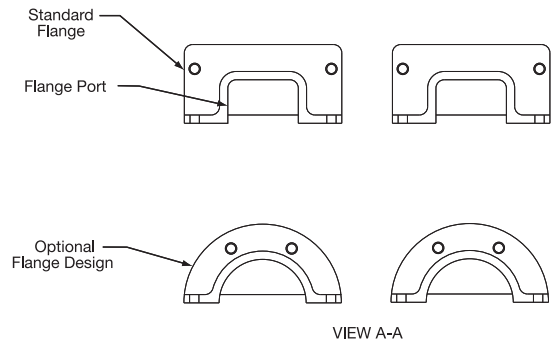
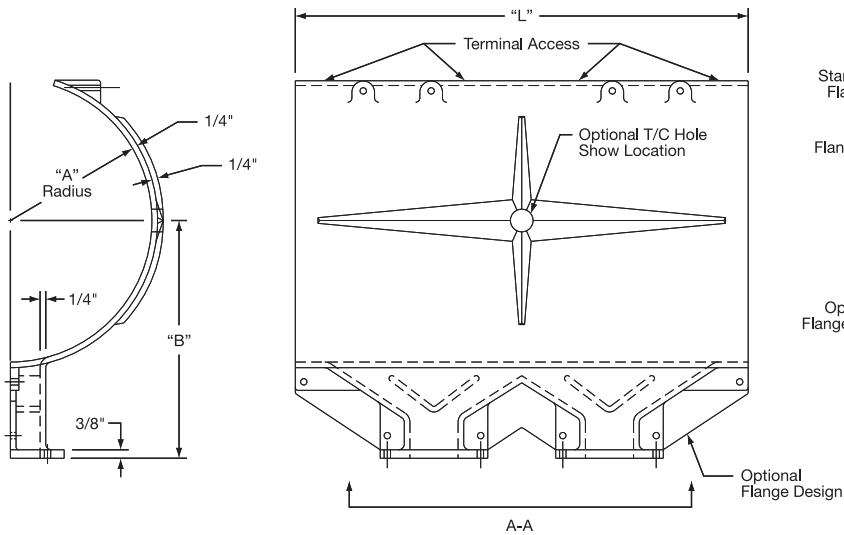

Please provide mounting hole specifications if using other than Tempco standard.

Shroud Style C

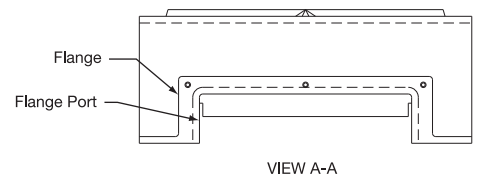
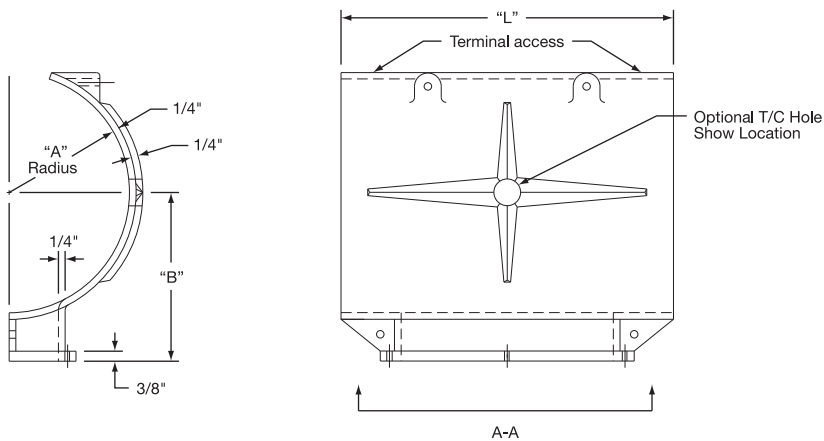

Please provide mounting hole specifications if using other than Tempco standard.

Cast-In Heaters



Arctic Cast® Shroud System

Made-To-Order Quote Request Form — Copy and Fax Us Your Requirements

Customer Information

Name: _____ Company: _____ City: _____ State: _____
 Phone: _____ Fax: _____ E-mail: _____
 Extruder Barrel Manufacturer: _____ Model Number: _____
 Resin Type: _____ Process Temperature: _____

When submitting this form, please be sure to include an extruder barrel sketch or drawing that includes the following:

- * Extruder Barrel Support(s) * Number of Heating Zones * Vent Location(s) * Zone Probe Location(s)
- * Input Feed Location * Pressure Tap Location(s) * Zone Length(s) * Additional Restriction(s)

Note: To assist Tempco in designing a shroud system, please provide digital images (in .jpg format) of the extruder barrel.

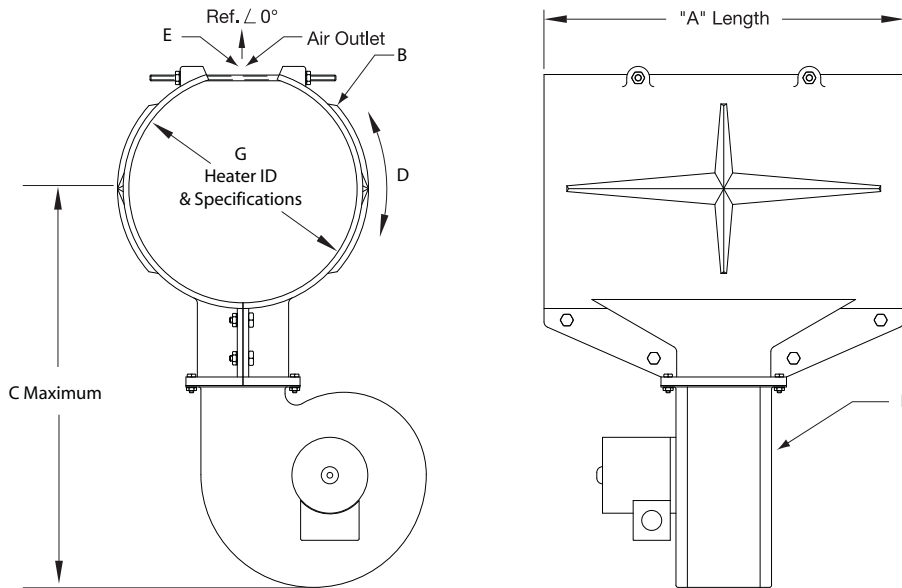

Shroud Specifications (For replacement of existing Tempco Shroud(s), please contact your Tempco Factory or Sales Representative.)

- A. Shroud Width / Zone Length: _____
 B. Maximum Shroud OD: _____ (Determined by Engineering unless specified by customer.)

Shroud Component Specifications

- C. Maximum Blower Clearance: _____
 D. Rotational Orientation of Air Outlet and Blower _____
 Indicate Angle from Vertical 0° Reference if other than 90° or 180° _____
 E. Zone T/C Probe(s): Quantity: _____ Clearance Hole Diameter: _____
 Location: Centered at Top (standard) Custom: _____ (Indicate Clockwise from Drawing Reference Angle)

Blower Specifications

- F. Configuration: Single Dual Customer Supplied (*see below)
 Stock Tempco Blower (Engineering will determine specifications if none specified)
 P/N: _____ or CFM: _____ Volts: _____ Operating Frequency: _____ Hz
 Optional Inlet Guard (Available for most stock blowers.)
 Optional Blower Extension: Horizontal Vertical Custom (Consult Tempco.)
 Mounting Dimensions: Length _____ Width _____
 *Customer Supplied Blower (Please attach mounting information when submitting this form.)
 Manufacturer: _____ P/N: _____ CFM: _____ Volts: _____ Operating Frequency: _____ Hz

Heater Specifications

- G. Extruder Barrel OD/Heater ID: _____ Wattage per Half: _____ Voltage per Half: _____