



**BASCO®  
TYPE "OP"  
(AEW) HEAT  
EXCHANGERS**



**API Heat Transfer**

*...world leaders in heat transfer technology*



## Quality, Value and Performance... An API Heat Transfer Tradition

*For over 60 years, original equipment manufacturers and aftermarket providers have looked to API Heat Transfer for a wide variety of heat transfer products.*

*The Basco® Type “OP” optimizes standardized components in a highly configurable design for a wide variety of process applications.*



## Standard Heat Exchanger Designs Deliver Cost Effective Performance

First introduced in 1962, the Basco OP design has proven to be the preferred TEMA Type AEW Shell & Tube Heat Exchanger in the market. The OP, or “O” Ring Protected design, is available in single or two pass. The Basco design features removable tube bundle, nozzle location flexibility and a unique threaded O-ring retainer that permits removal of the reversing bonnet without disturbing the piping or draining the shellside fluid. Then removal of the channel cover permits full inspection and cleaning of the tube side.

The unique O-ring retainer prevents the possibility of over-tightening the bolts and damaging the O-rings. This same retainer incorporates two “tell-tale” holes that warn the operator of any fluid leaks from either the shell or tube side.

API Basco has standardized this design using stock components. This means the solution to your cooling requirement is closer than ever.

### Quality

At API Heat Transfer, quality begins with properly applying the design to the process conditions, ensuring the design of the heat exchanger is mechanically correct for the service and applicable code requirements and finally manufacturing the unit to strict quality standards using only high quality code materials. The Basco OP has a proven track record for quality and service.

- Knowledgeable Application Engineers.
- Demand Flow Technology (DFT) to reduce lead-times, increase flexibility, improve efficiency, ensure consistently high quality and reduce cost.
- ASME, TEMA, API 614, ABS, USCG and other constructions available.

### Value

Value means obtaining the best features and performance required to meet a particular need at the best price and lead-time. API Heat Transfer knows this and has designed the Basco OP to exceed your expectations.

- Unique double O-ring sealed floating tube sheet provides leak detection and eliminates the possibility of over-tightening bolts, avoiding damage to the O-rings.
- Dome type shell nozzles available for higher flow rates at lower pressure drops.
- Highly efficient heat transfer with either bare or lo-fin tubes due to tight tolerances with baffles that minimizes fluid by-pass.
- Flexible configurations all manufactured from stock components means proven designs in the shortest possible lead-time.

### Performance

The wide range of OP configurations available have made these durable performers the first choice for a variety of cooling applications including:

- Compressed air
- Steam or gas turbine oil
- Hydraulic oil
- Lube oil
- Bearing water
- Jacket water
- Gland seal condensers
- Condensate cooling
- Ship board and marine engines

**Quality materials machined and assembled by an experienced, dedicated workforce result in consistently high quality finished products**

API Heat Transfer utilizes modern, high precision machining centers to convert raw materials into component parts. Then experienced skilled welders and assemblers transform these components into superior quality finished heat exchangers. High capacity oil flush stations, in-house shot blasting, controlled final paint application and even value-added packaging with other components such as valves and fans result in a heat exchanger fit for purpose and ready to provide years of trouble-free service.

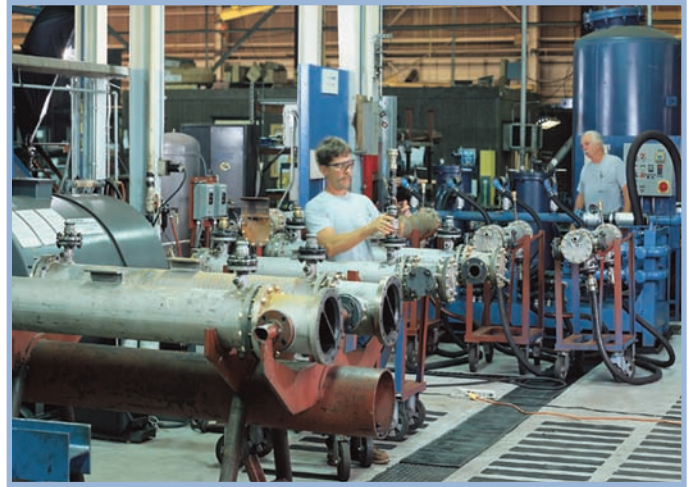

**Certified Demand Flow Production Methods and ISO Quality**

API Heat Transfer has fully embraced the superior quality, improved workflow and cost controls inherent in Demand Flow Technology (DFT) and Lean Manufacturing. Products are made “on-demand” from components and in-line support machining centers. With DFT, non-value procedures are eliminated, inventory costs are reduced and quality is maintained and verified at every phase of the assembly. API Heat Transfer also has ISO 9001 certification assuring world-class manufacturing methods and full accountability to our customers.



DFT, Lean Manufacturing and ISO 9001 result in reduced cycle times, increased flexibility, higher efficiencies, consistently high quality, and ...

**MORE VALUE FOR OUR CUSTOMERS!**



As one of the largest US manufacturers of industrial heat exchangers, API Heat Transfer’s investment in machinery and people, quality procedures and manufacturing processes, has proven to be the right strategy to earn our customers’ business over and over again.



# "OP" Exchanger Design Technology

## Basco Type "OP" Heat Exchanger

Offers cost-effective performance by utilizing standardized designs and stock components.

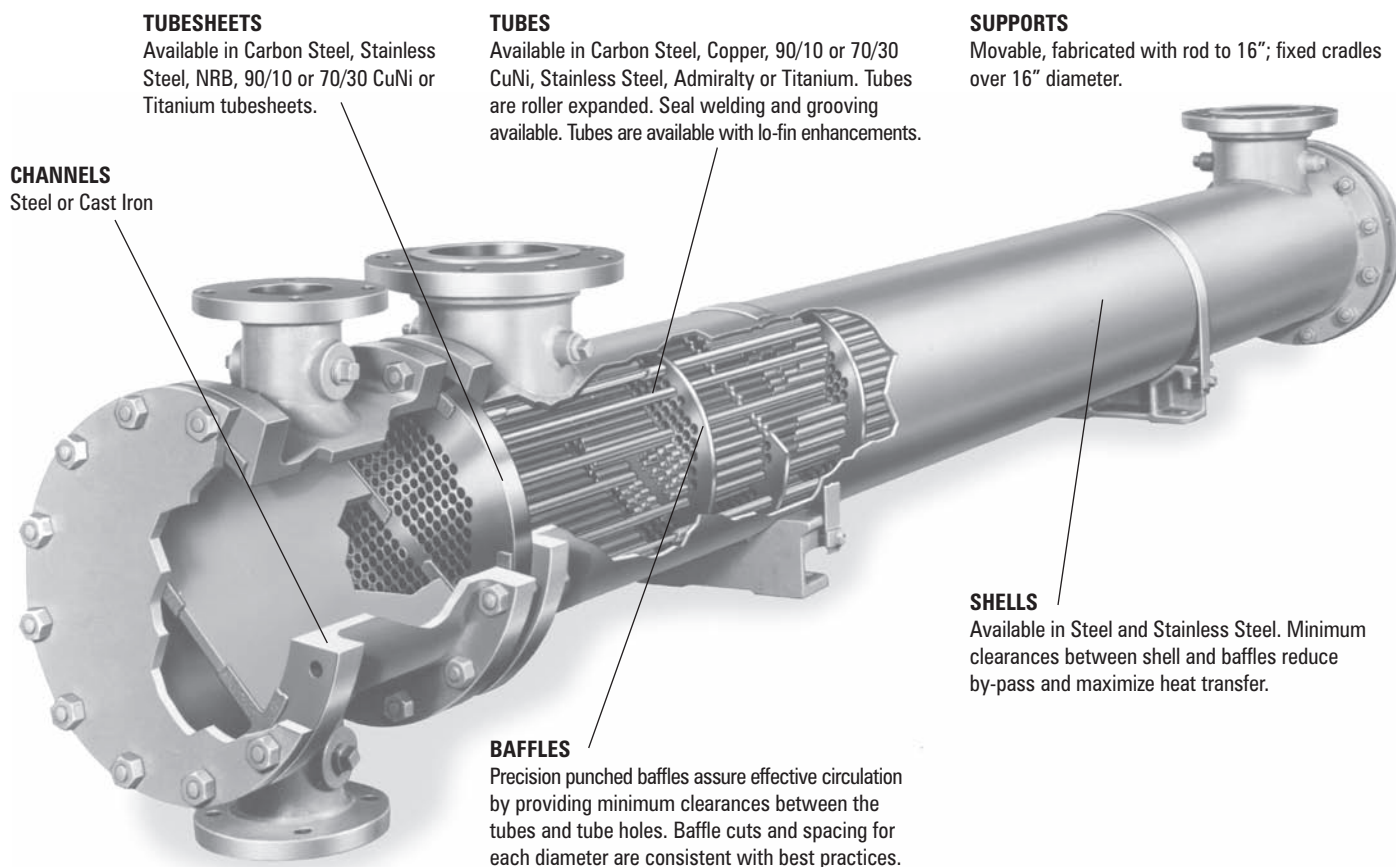

## Basco's Double "O" Ring Seal Protection

Permits tube bundle to expand and contract without strain or intermixing of shell and tubeside fluids. O-Rings retain compression and are unaffected by vibration and temperature changes. Telltale holes reveal any leakage.

## Special Feature

The unique construction of the Basco OP permits inspection and maintenance of the tubeside without draining the shellside or disturbing the piping.

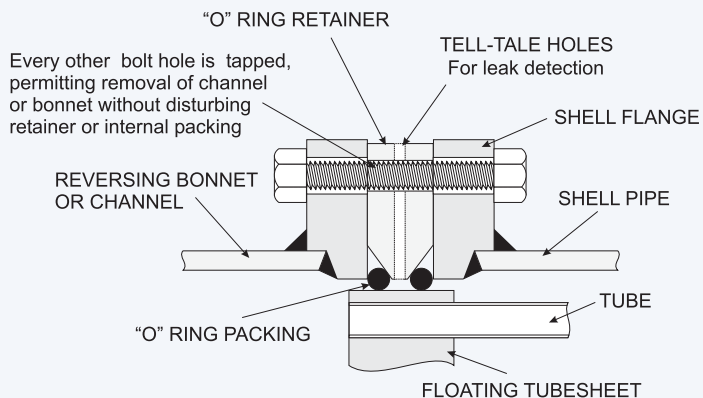

# Selecting Type "OP" Exchangers

## Standard Materials From Stock

Shell	Steel
Channel	Steel or Cast Iron
Reversing Bonnet	Steel or Cast Iron
"O" Rings	Buna "N"
Tubesheets	Steel or NRB
Baffles	Steel or Brass
Tubes	Admiralty (Bare or Lo-Fin)
	Copper (Bare)



## Standard Design Pressures & Temperatures

		Design Press.		Test Press.		Design Temp*	
		psi	kg/cm2	psi	kg/cm2	°F	°C
<b>Shellside</b>	All models	150	10.5	per code		300°	149°
<b>Tubeside</b>	3"-18" models	150	10.5	per code		300°	149°
	20"-42" models	75	5.3	per code		300°	149°

Complies with ASME-TEMA "C", AEW design. USCG, ABS and TUV approved.

\*Non-ferrous tubesheets designed for 300°F mean metal temperature.

## Determining Nozzle Locations

Single and two-pass models with a wide variety of nozzle locations are available. Select the desired nozzle location for the stationary and floating end of the exchanger from the chart on this page.

### Example:

The complete model designation for an 18" diameter, Type OP with a 120" tube length would be as follows:

**OP 18120-9-UU-5**

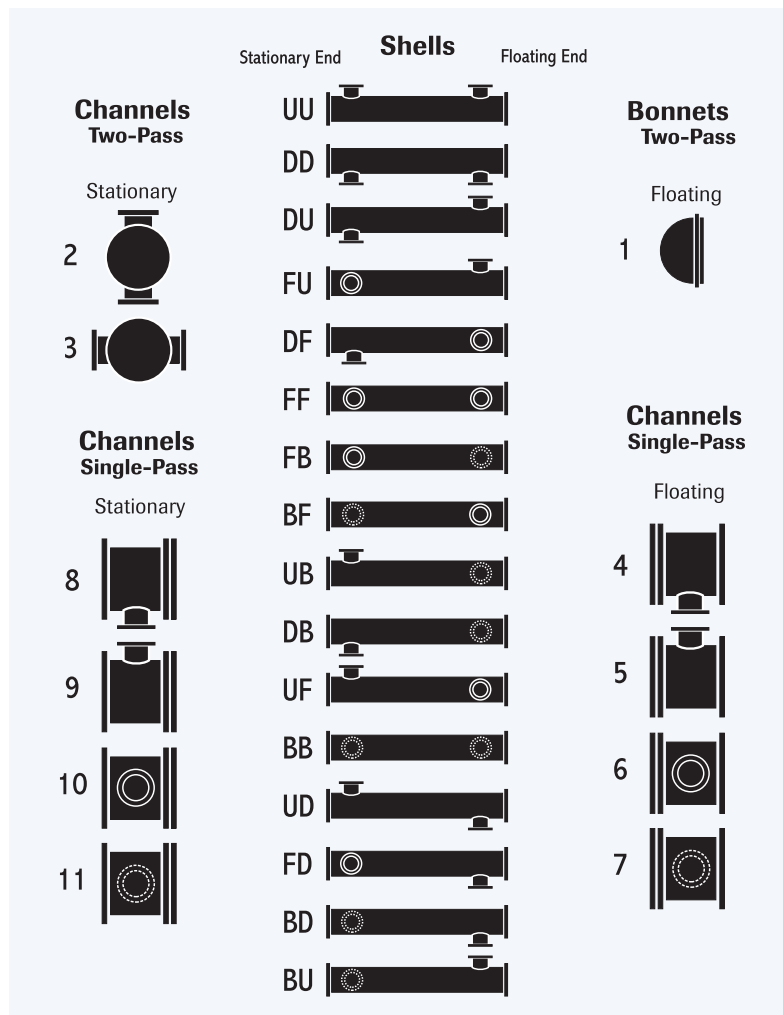
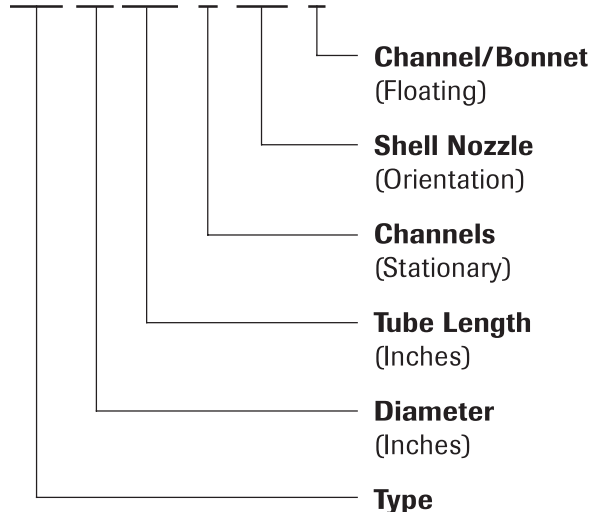

Nozzle locations

# Single Pass Type "OP" Heat Exchangers

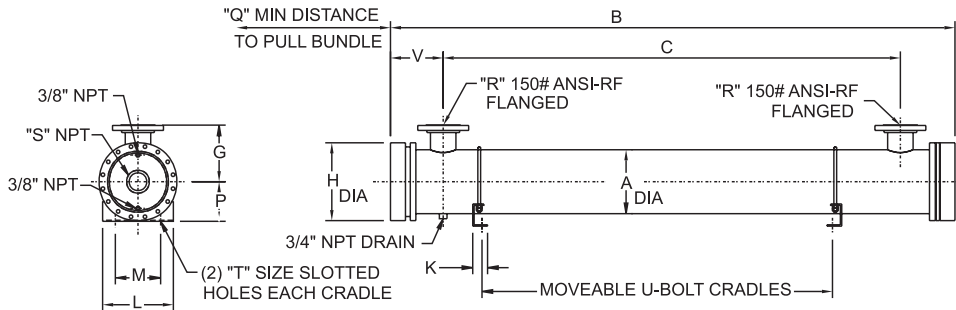
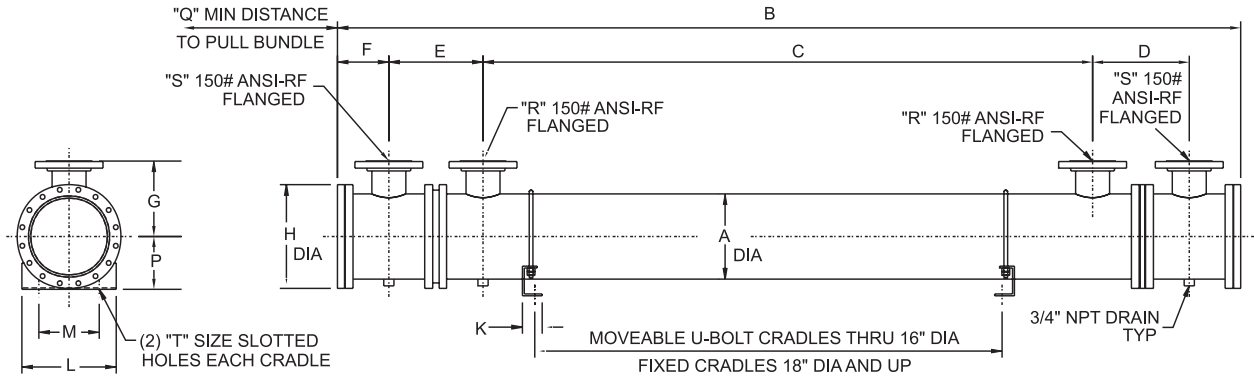

Model	A	B	C	D	E	F	G	H	K	L	M	P	Q	R	S	T	V
03120	3 1/2	137 7/16	111	8 9/16	8 3/8	4 3/4	7	6 3/8	2	5	3	3 1/2	118	1	1 1/2	5/8 x 7/8	6 9/16
04120	4 1/2	137 9/16	111	8 11/16	8 1/2	4 7/8	7	7 3/8	2	6	4	4	118	1 1/2	2	5/8 x 7/8	6 9/16
05120	5 9/16	140 3/16	111	9 3/16	9	5 1/2	7 1/2	8 1/2	2	7	5	4 1/2	118	1 1/2	2 1/2	5/8 x 7/8	6 9/16
06120	6 5/8	137 15/16	110 1/2	8 7/8	8 11/16	4 15/16	5 11/16	9	2	8	6 1/2	5	117	2	3	5/8 x 7/8	
08120	8 5/8	140 15/16	109	10 3/8	10 3/16	5 11/16	9	11 1/2	2	10	6 1/2	6	115	3	4	5/8 x 7/8	
10120	10 3/4	145 3/16	108	11 7/8	11 11/16	6 13/16	10	13 3/4	2 1/4	12 1/2	8	7	113	4	6	3/4 x 1	
12120	12 3/4	145 9/16	105 1/2	13 1/16	13 1/8	6 15/16	11	15 3/4	2 1/4	14 1/2	10	8 1/4	113	6	6	3/4 x 1	
14120	14	150 11/16	103	15 9/16	15 5/8	8 1/4	13	17	2 1/2	16	11	9 1/2	110	8	8	3/4 x 1 1/4	
16120	16	150 15/16	102 7/8	15 9/16	15 3/4	8 3/8	14	19	2 1/2	18	12	10 1/2	110	8	8	3/4 x 1 1/4	
18120	18	153 11/16	102 3/4	16 3/16	16 1/2	9 1/8	15	21	5 3/4	14	11	12 1/2	108	8	8	7/8	
20120	20	153 3/16	103 1/4	16 1/16	16 1/8	8 7/8	16	23	5 3/4	14 1/2	11 1/2	13 1/2	109	8	8	7/8	
22120	22	153 3/16	101 3/4	16 13/16	16 7/8	9 3/16	17	25	5 3/4	15	12	14 1/2	109	8	8	7/8	
24120	24	158 5/16	101	17 1/16	17 3/8	10 7/16	18	27	5 3/4	15 1/2	12 1/2	15 1/2	107	8	10	7/8	
25120	25 3/4	160 1/2	99 3/4	19 1/4	19 3/8	11 1/16	19	29 1/4	5 3/4	16	13	16 1/2	105	10	10	7/8	
27120	27 3/4	162 1/2	98 7/8	20 1/8	20 3/8	11 9/16	20	31 1/4	5 3/4	17	14	17 1/2	104	10	10	7/8	
29120	29 3/4	166 5/8	98 1/4	21 3/8	21 3/4	12 5/8	21	33 1/4	5 3/4	18	15	18 1/2	102	10	12	7/8	
31120	31 3/4	166 3/4	97 1/4	21 7/8	22 1/4	12 11/16	22	35 1/4	5 3/4	19	16	19 1/2	102	10	12	7/8	
33120	33 3/4	173	92 7/8	25 7/8	26 1/8	14 5/16	23	37 1/4	5 3/4	22	18 1/2	20 1/2	99	12	14	1	
35120	35 3/4	173	91 1/8	26 1/4	26 7/8	14 3/8	24	39 1/4	5 3/4	23	19 1/2	21 1/2	99	12	14	1	
37120	37 3/4	174 1/16	89 1/2	27 3/16	26	14 11/16	25	41 3/8	5 3/4	24	20 1/2	22 1/2	98	14	14	1	
39120	39 3/4	180 5/16	88 3/4	29 1/16	29 7/8	16 5/16	26	43 3/8	5 3/4	25	21 1/2	23 1/2	95	14	16	1	
42120	43	182 1/2	86 1/8	30 3/4	31 3/4	16 15/16	28	46 1/2	5 3/4	26	22 1/2	25	94	16	16	1	

Dimensions are in inches unless specified otherwise. Catalog dimensions are subject to variations. Use only certified drawings for construction.

## Using The Dimension Chart

Dimension chart shows common dimensions with 120" tube length. You must adjust any length dimensions accordingly for your model.

**Example:** Dimensional adjustments for a model 10144-1 with steel channels would be as follows:

"B" (overall length) - 145 3/16" + 24" = 169 3/16"; "C" (nozzle ctr-to-ctr) - 108" + 24" = 132"; "Q" (bundle removal) - 113" + 24" = 137"

# Two Pass Type "OP" Heat Exchangers

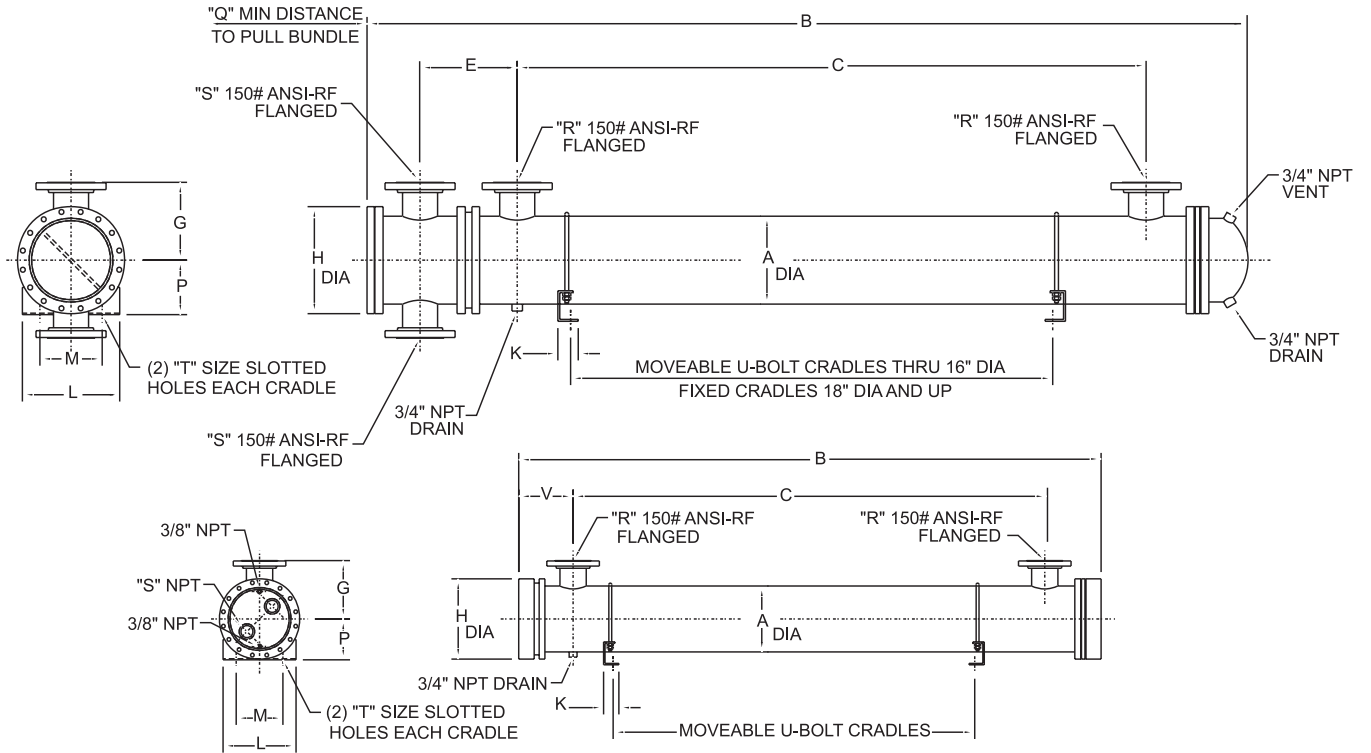

Model	A	B	C	D	E	F	G	H	K	L	M	P	Q	R	S	T	V
03120	3 1/2	129	111	5 7/8	7 7/8	4 1/4	7	6 3/8	2	5	3	3 1/2	118	1	1	5/8 x 7/8	6 9/16
04120	4 1/2	130 1/2	111	6 1/8	8 1/2	4 7/8	7	7 3/8	2	6	4	4	118	1 1/2	1 1/2	5/8 x 7/8	6 9/16
05120	5 9/16	131 1/4	111	6 3/4	8 1/2	5 1/2	7 1/2	8 1/2	2	7	5	4 1/2	118	1 1/2	1 1/2	5/8 x 7/8	6 9/16
06120	6 5/8	132 15/16	110 1/2	8 13/16	8 11/16	4 15/16	8	9 1/2	2	8	6 1/2	5	117	2	2	5/8 x 7/8	
08120	8 5/8	135 1/16	109	10 3/16	10 3/16	5 11/16	9	11 1/2	2	10	6 1/2	6	115	3	3	5/8 x 7/8	
10120	10 3/4	138 3/16	108	11 11/16	11 11/16	6 13/16	10	13 3/4	2 1/4	12 1/2	8	7	113	4	4	3/4 x 1	
12120	12 3/4	139	105 1/2	13 7/16	13 1/8	6 15/16	11	15 3/4	2 1/4	14 1/2	10	8 1/4	113	6	4	3/4 x 1	
14120	14	142 1/16	103	15 3/16	15 5/8	8 1/4	13	17	2 1/2	16	11	9 1/2	110	8	6	3/4 x 1 1/4	
16120	16	142 13/16	102 7/8	15 13/16	15 3/4	8 3/8	14	19	2 1/2	18	12	10 1/2	110	8	6	3/4 x 1 1/4	
18120	18	144 11/16	102 3/4	16 5/16	16 1/2	9 1/8	15	21	5 3/4	14	11	12 1/2	108	8	6	7/8	
20120	20	144 5/8	103 1/4	16 3/8	16 1/8	8 7/8	16	23	5 3/4	14 1/2	11 1/2	13 1/2	109	8	8	7/8	
22120	22	145 7/16	101 3/4	17 5/8	16 7/8	9 3/16	17	25	5 3/4	15	12	14 1/2	109	8	8	7/8	
24120	24	148 3/16	101	17 3/8	17 3/8	10 7/16	18	27	5 3/4	15 1/2	12 1/2	15 1/2	107	8	10	7/8	
25120	25 3/4	149 7/8	99 3/4	19 11/16	19 3/8	11 1/16	19	29 1/4	5 3/4	16	13	16 1/2	105	10	10	7/8	
27120	27 3/4	151 1/2	98 7/8	20 11/16	20 3/8	11 9/16	20	31 1/4	5 3/4	17	14	17 1/2	104	10	10	7/8	
29120	29 3/4	153 7/8	98 1/4	21 1/4	21 3/4	12 5/8	21	33 1/4	5 3/4	18	15	18 1/2	102	10	12	7/8	
31120	31 3/4	154 1/2	97 1/4	22 5/16	22 1/4	12 11/16	22	35 1/4	5 3/4	19	16	19 1/2	102	10	12	7/8	
33120	33 3/4	158 1/16	92 7/8	24 3/4	26 1/8	14 5/16	23	37 1/4	5 3/4	22	18 1/2	20 1/2	99	12	14	1	
35120	35 3/4	158 1/2	91 1/8	26 1/8	26 7/8	14 3/8	24	39 1/4	5 3/4	23	19 1/2	21 1/2	99	12	14	1	
37120	37 3/4	159 1/2	89 1/2	27 5/16	26	14 11/16	25	41 3/8	5 3/4	24	20 1/2	22 1/2	98	14	14	1	
39120	39 3/4	161 5/16	88 3/4	28 3/8	29 7/8	16 5/16	26	43 3/8	5 3/4	25	21 1/2	23 1/2	95	14	14	1	
42120	43	165 3/8	86 1/8	30 9/16	31 3/4	16 15/16	28	46 1/2	5 3/4	26	22 1/2	25	94	16	16	1	

Dimensions are in inches unless specified otherwise. Catalog dimensions are subject to variations. Use only certified drawings for construction.

## Using The Dimension Chart

Dimension chart shows common dimensions with 120" tube length. You must adjust any length dimensions accordingly for your model.

**Example:** Dimensional adjustments for a model 10144-2 with steel channels would be as follows:

"B" (overall length) - 138 3/16" + 24" = 162 3/16"; "C" (nozzle ctr-to-ctr) - 108" + 24" = 132"; "Q" (bundle removal) - 113" + 24" = 137"