

Fig. 62, Type A, B and C

Pipe Stanchion

Size Range: 2" through 18"

Material: Carbon steel

Finish: Plain or Galvanized

Service: Stanchion type of support for stationary pipe where vertical adjustment is required.

Maximum Temperature: Plain 650° F, Galvanized 450° F

Ordering: Specify figure number, type, pipe size, top stanchion size, material specification and "D" dimension. For base plates that require holes, also specify hole size, and the center line to center line of the holes.

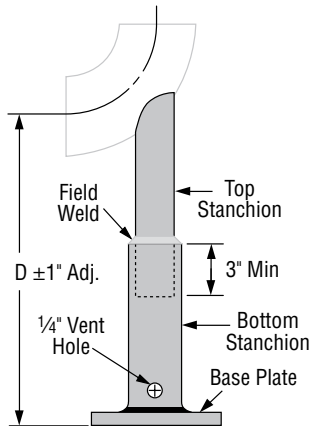

Fig. 62, Type A
(L. R. Elbow) with adjustable base

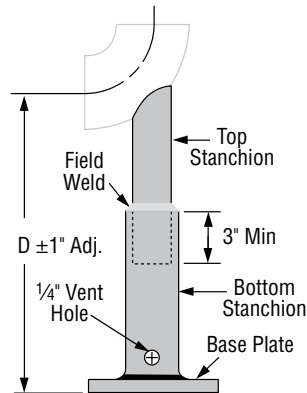

Fig. 62, Type B
(S. R. Elbow) with adjustable base

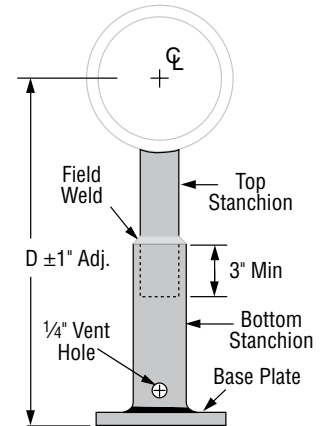

Fig. 62, Type C
(Horizontal Pipe) with adjustable base

Pipe or Elbow Size (in)	Top Stanchion Size (Standard Weight Pipe)			
	1½	2½	4	5
2	•			
2½	•			
3	•	•		
4	•	•		
5	•	•	•	
6		•	•	•
8			•	•
10			•	•
12				•
14				•
16				•
18				•
Weight (Lbs)	12	28	55	75

- Indicates available stanchion size for pipe or elbow size.
- Weights based on a "D" dimension of 2'-0".

DIMENSIONS (IN)		
Top Stanchion	Bottom Stanchion	Base Plate
1½	2 Std.	¾ x 6 x 6
2½	3 Std.	¾ x 10 x 10
4	5 Sch. 80	¾ x 10 x 10
5	6 Sch. 80	¾ x 10 x 10



Fig. 62
Stanchion with Adjustable Base