

FIG. 7401

Rigidlok® Coupling

The Fig. 7401 Rigidlok Coupling from Gruvlok provides a rigid pipe connection. Rigidity is attained simply; it is designed in.

The Fig. 7401 Rigidlok coupling utilizes a technologically advanced housing design that conforms to and grips the pipe. With the Fig. 7401 there emerges a new generation of rigid couplings.

Coupling installation is fast and easy, remove only one nut and swing the housing over the gasket and into the grooves. The exclusive Guidelok® feature automatically separates the grooved pipe ends and guides the coupling into position as the bolts are tightened. Precisely sized and oriented tines in the housing key section firmly grip the pipe. The combination of these designed in features produce a secure, rigid pipe joint connection.

This coupling is an ideal connector for service and applications that require a rigid connection.

The Fig. 7401 Rigidlok Coupling is designed for use with roll grooved or cut grooved standard weight and roll grooved lightweight pipe, as well as with grooved-end fittings and valves. The Rigidlok Coupling maintains a rigid connection with





 For Listings/Approval Details and Limitations, visit our website at www.anvilintl.com or contact an Anvil® Sales Representative.

support and hanging in conformance with applicable ANSI B31.1 Power Piping Code, ANSI B31.9 Building Service Pipe Code as well as NFPA 13 sprinkler systems.

The Fig. 7401 Rigidlok Coupling allows for working pressure ratings to 750 psi (51.7 bar) when used on standard wall roll or cut grooved pipe.

MATERIAL SPECIFICATIONS

ANSI BOLTS & HEAVY HEX NUTS:

Heat treated, oval neck track head bolts conforming to ASTM A 183 Grade 2 with a minimum tensile strength of 110,000 psi and heavy hex nuts of carbon steel conforming to ASTM A 563 Grade A or Grade B, or J995 Grade 2. Bolts and nuts are provided zinc electroplated as standard.

METRIC BOLTS & HEAVY HEX NUTS:

Heat treated, zinc electroplated oval-neck track head bolts made of carbon steel with mechanical properties per ISO 898-1 Class 8.8. Hex nuts are zinc electroplated followed by a yellow chromate dip.

STAINLESS STEEL BOLTS & NUTS:

304SS Stainless Steel bolts and nuts are available as a standard option. (316SS are available for special order).

HOUSING:

Ductile Iron conforming to ASTM A 536, Grade 65-45-12

COATINGS:

Rust inhibiting paint – Color: ORANGE (standard)
 Hot Dipped Zinc Galvanized (optional)
 Other Colors Available (IE: RAL3000 and RAL9000)
 For other Coating requirements contact an Anvil Representative.

GASKETS: Materials

Properties as designated in accordance with ASTM D 2000

Grade “EP” EPDM (Green and Red color code)

-40°F to 250°F (Service Temperature Range)(-40°C to 121°C)
 Recommended for water service, diluted acids, alkalies solutions, oil-free air and many other chemical services.
 NOT FOR USE IN PETROLEUM APPLICATIONS.

For hot water applications the use of Gruvlok Extreme Temperature lubricant is recommended. NSF-61 Certified for cold and hot water applications up through 12”.

Grade “T” Nitrile (Orange color code)

-20°F to 180°F (Service Temperature Range)(-29°C to 82°C)
 Recommended for petroleum applications. air with oil vapors and vegetable and mineral oils.
 NOT FOR USE IN HOT WATER OR HOT AIR

Grade “O” Fluoro-Elastomer (Blue color code)

Size Range: 1” - 12” (C style only)
 20°F to 300°F (Service Temperature Range)(-29°C to 149°C)
 Recommended for high temperature resistance to oxidizing acids, petroleum oils, hydraulic fluids, halogenated hydrocarbons and lubricants.

Grade “L” Silicone (Red color code)

Size Range: 1” - 12” (C style only)
 -40°F to 350°F (Service Temperature Range)(-40°C to 177°C)
 Recommended for dry, hot air and some high temperature chemical services. Contact an Anvil Representative for availability.

GASKET TYPE:

C Style (1” - 24”)
 Flush Gap (1” - 24”)

LUBRICATION:

Standard
 Gruvlok Xtreme™ (Do Not use with Grade “L”)

FIG. 7401 Rigidlok® Coupling

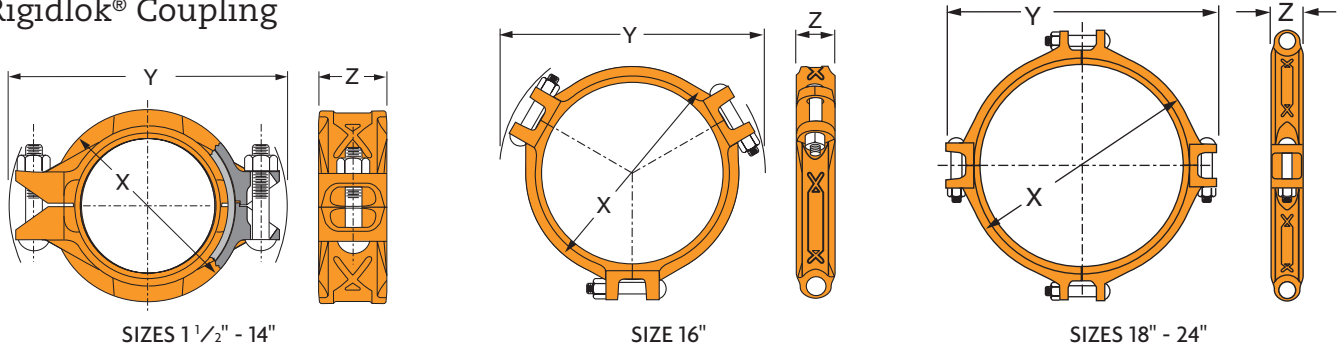

FIGURE 7401 RIGIDLOK COUPLING

Nominal Size	O.D.	Max. Working Pressure	Max. End Load	Range of Pipe End Separation	Coupling Dimensions			Coupling Bolts*		Specified Torque §		Approx. Wt. Ea.
					X	Y	Z	Qty.	Size	Min.	Max.	
In./DN(mm)	In./mm	PSI/bar	Lbs./kN	In./mm	In./mm	In./mm	In./mm		In./mm	Ft.-Lbs/N-M		Lbs./kg
1½ 40	1.900 48.3	750 51.7	2,126 9.46	0-½ 0-0.79	3 76	5½ 130	1½ 48	2	¾ x 2¼ M10 x 57	30 40	45 60	1.8 0.8
2 50	2.375 60.3	750 51.7	3,323 14.78	0-½ 0-0.79	3½ 89	5½ 143	1½ 48	2	¾ x 2½ M10 x 63	30 40	45 60	2.4 1.1
2½ 65	2.875 73.0	750 51.7	4,869 21.66	0-½ 0-0.79	4 102	6½ 156	1½ 48	2	¾ x 2½ M10 x 63	30 40	45 60	2.9 1.3
3 O.D. 76.1	2.996 76.1	750 51.7	5,207 23.52	0-½ 0-0.79	4½ 105	6½ 156	1½ 48	2	¾ x 2½ M10 x 63	80 110	100 150	3.4 1.5
3 80	3.500 88.9	750 51.7	7,216 32.10	0-½ 0-0.79	4¾ 121	7¼ 184	1½ 48	2	½ x 3 M12 x 76	80 110	100 150	3.6 1.6
4 100	4.500 114.3	750 51.7	11,928 53.06	0-½ 0-2.38	5½ 149	8½ 213	2½ 54	2	½ x 3 M12 x 76	80 110	100 150	5.0 2.3
5½ O.D. 139.7	5.500 139.7	750 51.7	17,819 79.26	0-½ 0-2.38	7 178	9¼ 248	2½ 54	2	¾ x 3½ M16 x 85	100 135	130 175	6.9 3.1
5 125	5.563 141.3	750 51.7	18,229 81.09	0-¾ 0-2.38	7 178	10 254	2½ 54	2	¾ x 3½ M16 x 85	100 135	130 175	6.9 3.1
6½ O.D. 165.1	6.500 165.1	750 51.7	24,887 110.70	0-¾ 0-2.38	8 203	11 279	2½ 54	2	¾ x 3½ M16 x 85	100 135	130 175	7.6 3.4
6 150	6.625 168.3	750 51.7	25,854 115.00	0-¾ 0-2.38	8½ 206	11½ 283	2½ 54	2	¾ x 3½ M16 x 85	100 135	130 175	7.9 3.6
8 200	8.625 219.1	600 41.4	35,056 155.94	0-¾ 0-2.38	10½ 267	14½ 359	2½ 67	2	¾ x 4½ M20 x 110	130 175	180 245	15.9 7.2
10 250	10.750 273.1	500 34.5	45,381 201.87	0-¾ 0-2.38	12½ 327	17½ 445	2½ 67	2	1 x 6 M24 x 150	200 270	250 340	25.6 11.6
12 300	12.750 323.9	400 27.6	51,070 227.17	0-¾ 0-2.38	15 381	19½ 495	2½ 67	2	¾ x 6 M22 x 150	180 245	220 300	30.5 13.8
14 350	14.000 355.6	300 20.7	46,181 205.43	0-¾ 0-2.38	16¼ 413	19¾ 502	3 76	2	¾ x 5½ M22 x 140	180 245	220 300	36.1 16.4
16 400	16.000 406.4	300 20.7	60,319 268.31	0-¾ 0-2.38	18½ 460	22¼ 565	3 76	3	¾ x 5½ M22 x 140	180 245	220 300	42.0 19.1
18 450	18.000 457.2	300 20.7	76,341 339.58	0-¾ 0-2.38	20½ 521	24¾ 619	3½ 79	4	1 x 4 M24 x 100	200 270	250 340	51.6 23.4
20 500	20.000 508.0	300 20.7	94,248 419.23	0-¾ 0-2.38	23 581	26¾ 683	3½ 79	4	1 x 4 M24 x 100	200 270	250 340	68.3 31.0
24 600	24.000 609.6	250 17.2	113,097 503.08	0-¾ 0-2.38	27½ 689	30¾ 784	3½ 79	4	1 x 4 M24 x 100	200 270	250 340	89.3 40.5

NOTE:
Range of Pipe End Separation values are for roll grooved pipe and may be doubled for cut groove pipe.

For additional details see "Coupling Data Chart Notes" on page 17.
* Available in ANSI or metric bolt sizes only as indicated.
§ - For additional Bolt Torque information, see page 204.
See Installation & Assembly directions on page 163.
Not for use in copper systems.