

## Fig. 258

## Pipe Saddle Support

**Size Range:** 4" through 36"

**Material:** Sizes 4" through 12" are Cast Iron. Sizes 14" through 36" are Carbon Steel. Sizes 4" through 12" are available in Carbon Steel by special request only.

**Finish:** Plain or Galvanized

**Service:** Stanchion type support for **stationary** pipe.

**Approvals:** Complies with Federal Specification A-A-1192A (Type 36), WW-H-171-E (Type 36 & 37), ANSI/MSS SP-69 and MSS SP-58 (Type 36).

**Installation:** Slip saddle base into riser pipe.

**Ordering:** Specify size to be supported, figure number, name, finish and material.

**Order Separately:** Figure 63P Square Cut End Stanchion. Specify "H" and pipe size to be supported by Figure 258.



Fig. 258 Cast

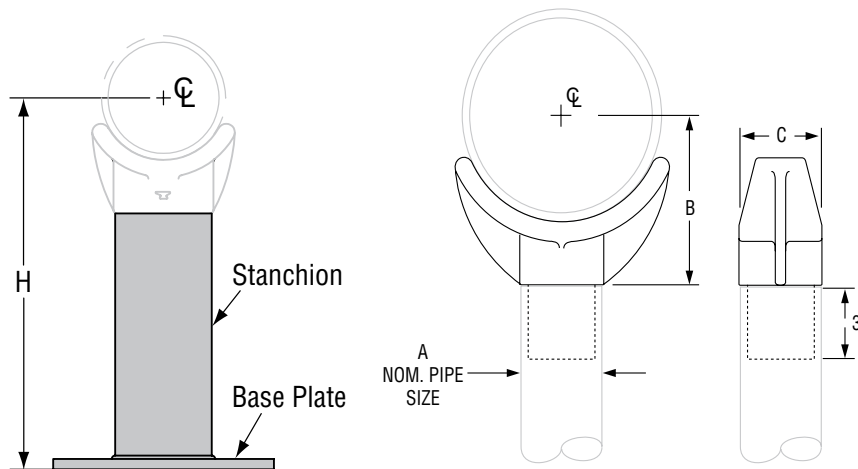

Fig. 63, Type P

Square Cut End for use with Figure 258 or 259 Pipe Saddle Support



Fig. 258 Fabricated Steel

### FIG. 258: WEIGHTS (LBS) • DIMENSIONS (IN)

Pipe Size	Weight	A	B	Width C	Max Load
4	9.1	3	4 <sup>3</sup> / <sub>16</sub>	3 <sup>5</sup> / <sub>8</sub>	3,800
5	10.8		4 <sup>13</sup> / <sub>16</sub>		
6	11.8		5 <sup>7</sup> / <sub>16</sub>		
8	14.3		6 <sup>15</sup> / <sub>16</sub>		
10	19.3		8 <sup>7</sup> / <sub>16</sub>		
12	23.1		9 <sup>15</sup> / <sub>16</sub>		
14	15.0	4	10 <sup>1</sup> / <sub>2</sub>	4	5,300
16	16.0		11 <sup>1</sup> / <sub>2</sub>		
18	23.0		13 <sup>1</sup> / <sub>2</sub>	5	7,300
20	24.0		14 <sup>1</sup> / <sub>2</sub>		
22	26.0		15 <sup>1</sup> / <sub>2</sub>		
24	30.0		17 <sup>1</sup> / <sub>2</sub>		
26	32.0		18 <sup>1</sup> / <sub>2</sub>		
30	41.0		20 <sup>5</sup> / <sub>8</sub>		
32	42.0		21 <sup>5</sup> / <sub>8</sub>	8 <sup>3</sup> / <sub>4</sub>	
36	46.0		23 <sup>5</sup> / <sub>8</sub>		

\*Standard Wall Pipe The above load ratings are applicable to the saddle only and are not applicable to the stanchion or other means used to support the saddle.