

STEEL PIPE CLAMPS

Fig. 295

Double Bolt Pipe Clamp

Size Range: 3/4" through 36"

Material: Carbon steel

Finish: Plain or Galvanized

Service: Recommended for suspension of pipe requiring insulation within the limitation of temperature and loads shown below.

Maximum Temperature: Plain 750° F, Galvanized 450° F

Approvals: Complies with Federal Specification A-A-1192A (Type 3), WW-H-171-E (Type 3), ANSI/MSS SP-69 and MSS SP-58 (Type 3).

Installation: Attachment to the clamp may be made with a welded eye rod Fig. 278, page 98 or the weldless eye nut Fig. 290, see page 102.

Features:

- Sizes 6" and above accommodate up to 4" thick insulation.
- Figure 41SD will accommodate larger insulation thicknesses, loads and dimensions.

Ordering: Specify pipe size, figure number, name and finish.

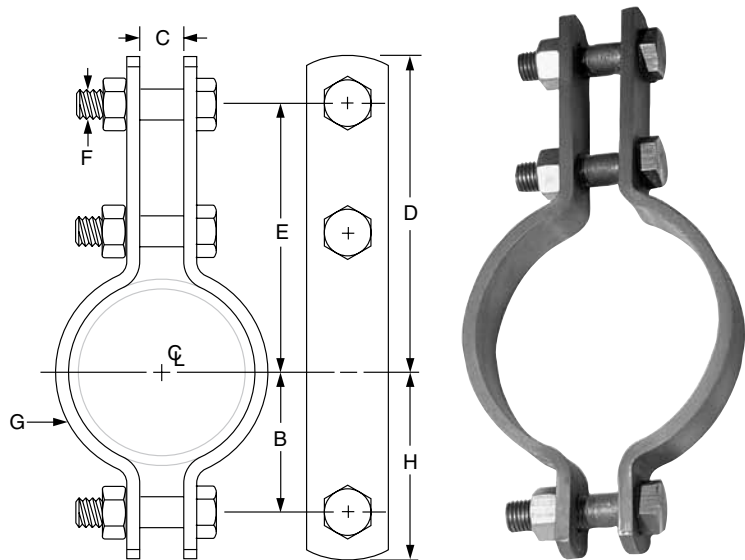

Note: This picture is representative of a typical Figure 295. Distance between clamp ears beneath pipe may or may not be equal to upper gap.

FIG. 295: LOADS (LBS) • WEIGHT (LBS) • DIMENSIONS (IN)

Pipe Size	Max Span Ft.	Max Load For Service Temp.		Weight	B	C	D	Rod Take Out E	F	G Width	H
		650° F	750° F								
3/4	7*	950	—	0.7	15/16	5/8	27/8	27/16	3/8	1	13/8
1			—	0.8	11/16		3	29/16			11/2
1 1/4			—	0.8	11/4		3 1/8	211/16			11 1/16
1 1/2	9*	1,545	1,380	2.3	113/16	1 1/16	47/8	41/8	5/8	1 1/4	23/8
2	10*			2.6	21/8		57/8	51/8			21 1/16
2 1/2	11*			1.97	25/8	5/8	6	53/8	1/2	1	3 1/4
3	12*			2.17	27/8		65/8	6			3 1/2
4	14*	2,500	2,230	6.7	33/8	1 1/16	75/8	6 1/2	3/4	2	4 1/2
5	16*			7.0	315/16		81/8	7			5
6	17*	2,865	2,555	7.31	47/8	1 1/4	93/8	8 1/2	3/4	2 1/2	5 3/4
8	19*			8.33	6		103/8	9 1/2			6 7/8
10	22*	3,240	2,890	19.8	67/8	1 7/16	12	107/16	1	2 1/2	8 1/4
12	23"			22.3	77/8		13	117/16			9 1/4
14	20			4,300	3,835	37.7	91/16	2	145/16	1211/16	1 1/4
16	15	41.4	101/16			155/16	1311/16		11 11/16		
18		44.9	111/16			165/16	1411/16		12 11/16		
20		12	5,490			4,900	57.3		123/8	175/8	
24	12	4,500	4,015	65.9	143/8	193/8	177/8	1 3/8	16		
28	—	6,000	—	112.3	17 1/2	2 1/4	24 1/4	21 3/4	1 1/4	4	20
30	9	7,500	—	150.0	18 1/2	2 1/2	26 1/8	23 3/8	1 3/8	5	21 1/4
32	—	8,250	—	193.3	19 5/8		28	25	1 1/2	6	22 5/8
34	—	9,800	—	248.8	21 1/2	3	31 1/4	27 3/4	1 3/4	5	25
36	—	10,500	—	257.5	22 1/2		32 1/4	28 3/4			1 3/4

Clamps may be furnished with square ends. "Span" represents the maximum recommended distance between hangers on a continuous and straight run of horizontal standard weight steel pipe filled with water. In all cases, verify that chosen location of hangers does not subject hangers to a load greater than the maximum recommended load shown above. *Indicates that span represents the maximum span for water filled pipe as given in Table 1 of page 249. For vapor service, the presence of fittings or insulation, and other weights and types of pipe, spans may either increase or decrease. In all cases, verify that chosen location of hanger does not subject hangers to a load greater than the maximum recommended load shown.