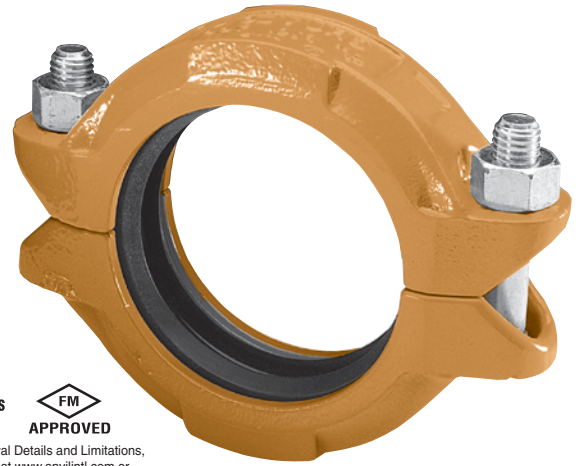

FIG. 7001

Flexible Coupling

The Gruvlok® Fig. 7001 Coupling forms a flexible grooved end pipe joint connection with the versatility for a wide range of applications. Services include mechanical and plumbing, process piping, mining and oil field piping, and many others. The coupling design supplies optimum strength for working pressures to 1000 PSI (69 bar) without excessive casting weight.

The flexible design eases pipe and equipment installation while providing the designed-in benefit of reducing pipeline noise and vibration transmission without the addition of special components. To ease coupling handling and assembly and to assure consistent quality, sizes 1" through 14" couplings have two 180° segment housings, 16" have three 120° segment housings, and 18" through 24" sizes have four 90° segment housings, while the 28" O.D. and 30" O.D. couplings have six 60° segment housings. The 28" O.D. and 30" O.D. are weld-ring couplings.



For Listings/Approval Details and Limitations, visit our website at www.anvilintl.com or contact an Anvil® Sales Representative.

MATERIAL SPECIFICATIONS

ANSI BOLTS & HEAVY HEX NUTS:

Heat treated, oval neck track head bolts conforming to ASTM A 183 Grade 2 with a minimum tensile strength of 110,000 psi and heavy hex nuts of carbon steel conforming to ASTM A 563 Grade A or Grade B, or J995 Grade 2. Bolts and nuts are provided zinc electroplated as standard.

METRIC BOLTS & HEAVY HEX NUTS:

Heat treated, zinc electroplated oval-neck track head bolts made of carbon steel with mechanical properties per ISO 898-1 Class 8.8. Hex nuts are zinc electroplated followed by a yellow chromate dip.

STAINLESS STEEL BOLTS & NUTS:

304SS Stainless Steel bolts and nuts are available as a standard option. (316SS are available for special order).

HOUSING:

Ductile Iron conforming to ASTM A 536, Grade 65-45-12

COATINGS:

Rust inhibiting paint – Color: ORANGE (standard)
Hot Dipped Zinc Galvanized (optional)
Other Colors Available (IE: RAL3000 and RAL9000)
For other Coating requirements contact an Anvil Representative.

GASKETS: Materials

Properties as designated in accordance with ASTM D 2000

Grade “EP” EPDM (Green and Red color code)

-40°F to 250°F (Service Temperature Range)(-40°C to 121°C)
Recommended for water service, diluted acids, alkalis solutions, oil-free air and many other chemical services.
NOT FOR USE IN PETROLEUM APPLICATIONS.

For hot water applications the use of Gruvlok Extreme Temperature lubricant is recommended. NSF-61 Certified for cold and hot water applications up through 12".

Grade “T” Nitrile (Orange color code)

-20°F to 180°F (Service Temperature Range)(-29°C to 82°C)
Recommended for petroleum applications. Air with oil vapors and vegetable and mineral oils.
NOT FOR USE IN HOT WATER OR HOT AIR

Grade “O” Fluoro-Elastomer (Blue color code)

Size Range: 1" - 12" (C style only)
20°F to 300°F (Service Temperature Range)(-29°C to 149°C)
Recommended for high temperature resistance to oxidizing acids, petroleum oils, hydraulic fluids, halogenated hydrocarbons and lubricants.

Grade “L” Silicone (Red color code)

Size Range: 1" - 12" (C style only)
-40°F to 350°F (Service Temperature Range)(-40°C to 177°C)
Recommended for dry, hot air and some high temperature chemical services. Contact an Anvil Representative for availability.

GASKET TYPE:

C Style (1" - 30")
Flush Gap (1" - 24")

LUBRICATION:

Standard
Gruvlok Xtreme™ (Do Not use with Grade “L”)

WORKING PRESSURE, END LOAD, PIPE END SEPARATION & DEFLECTION FROM CENTER LINE:

Based on standard wall steel pipe with cut or roll grooves in accordance with Gruvlok specifications. See technical data section for design factors.

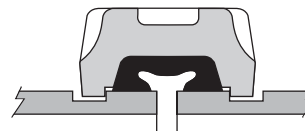

Fig. 7001 with Standard Gasket

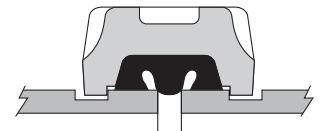
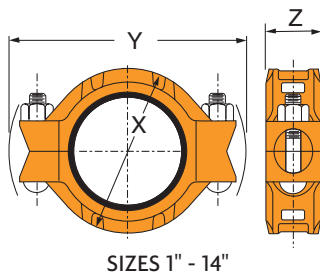
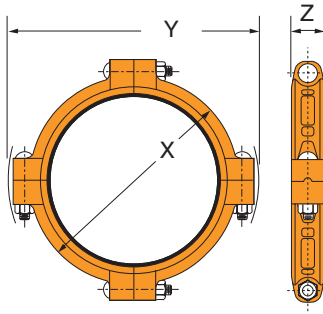

Fig. 7001 with Flush Gap Gasket

FIG. 7001
Flexible Coupling



SIZES 1" - 14"



SIZES 16" - 24"

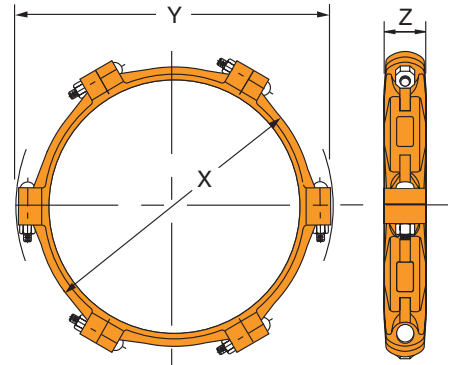

SIZES 28" - 30"

FIGURE 7001 FLEXIBLE COUPLING

Nominal Size	O.D.	Max. Work. Pressure	Max. End Load	Range of Pipe End Separation	Deflection from C		Coupling Dimensions			Bolt Dimensions*		Specified Torque §		Approx. Wt. Ea.
					Per Coupling	of Pipe	X	Y	Z	Qty.	Size	Min.	Max.	
In./DN(mm)	In./mm	PSI/bar	Lbs./kN	In./mm	Degrees(-)Minutes(')	In./ft.-mm/m	In./mm	In./mm	In./mm		In./mm	Ft.-Lbs/N-m	Lbs./kg	
1 25	1.315 33.4	1000 68.9	1,358 6.04	0-1/32 0-0.79	1° 22'	0.29 23.8	2 1/2 64	4 1/2 114	1 1/8 48	2	3/8 x 2 1/4 M10 x 57	30 40	45 60	1.3 0.6
1 1/4 32	1.660 42.2	1000 68.9	2,164 9.63	0-1/32 0-0.79	1° 5'	0.23 18.8	2 3/4 70	4 1/2 114	1 1/8 48	2	3/8 x 2 1/4 M10 x 57	30 40	45 60	1.4 0.6
1 1/2 40	1.900 48.3	1000 68.9	2,835 12.61	0-1/32 0-0.79	0° 57'	0.20 16.5	3 76	4 5/8 117	1 1/8 48	2	3/8 x 2 1/4 M10 x 57	30 40	45 60	1.5 0.7
2 50	2.375 60.3	1000 68.9	4,430 19.71	0-1/32 0-0.79	0° 45'	0.16 13.1	3 3/8 92	6 1/8 156	1 1/8 48	2	1/2 x 3 M12 x 76	80 110	100 150	3.1 1.4
2 1/2 65	2.875 73.0	1000 68.9	6,492 28.88	0-1/32 0-0.79	0° 37'	0.13 10.9	4 1/4 108	6 1/2 165	1 1/8 48	2	1/2 x 3 M12 x 76	80 110	100 150	3.7 1.7
3 O.D. 76.1	2.996 76.1	1000 68.9	7,050 31.36	0-1/32 0-0.79	0° 36'	0.13 10.4	4 1/4 108	6 3/4 171	1 1/8 48	2	1/2 x 3 M12 x 76	80 110	100 150	4.3 2.0
3 80	3.500 88.9	1000 68.9	9,621 42.80	0-1/32 0-0.79	0° 31'	0.11 8.9	4 3/8 124	7 1/8 181	1 1/8 48	2	1/2 x 3 M12 x 76	80 110	100 150	4.3 2.0
3 1/2 90	4.000 101.6	1000 68.9	12,566 55.90	0-1/32 0-0.79	0° 27'	0.09 7.8	5 1/4 133	8 1/4 210	1 1/8 48	2	5/8 x 3 1/2 M16 x 89	100 135	130 175	5.1 2.3
4 100	4.500 114.3	1000 68.9	15,904 70.75	0-3/32 0-2.38	1° 12'	0.25 20.8	6 1/4 159	8 3/4 222	2 51	2	5/8 x 3 1/2 M16 x 89	100 135	130 175	6.8 3.1
5 125	5.563 141.3	1000 68.9	24,306 108.12	0-3/32 0-2.38	0° 58'	0.20 16.8	7 1/4 184	11 1/4 286	2 51	2	3/4 x 4 1/2 M20 x 110	130 175	180 245	9.6 4.4
6 1/2 O.D. 165.1	6.500 165.1	1000 68.9	33,183 147.61	0-3/32 0-2.38	0° 50'	0.17 14.4	8 1/4 210	11 1/4 298	2 51	2	3/4 x 4 1/2 M20 x 110	130 175	180 245	11.8 5.4
6 150	6.625 168.3	1000 68.9	34,472 153.34	0-3/32 0-2.38	0° 49'	0.17 14.1	8 3/8 219	11 1/4 298	2 51	2	3/4 x 4 1/2 M20 x 110	130 175	180 245	11.8 5.4
8 200	8.625 219.1	800 55.2	46,741 207.91	0-3/32 0-2.38	0° 37'	0.13 10.9	11 279	14 3/8 365	2 3/8 60	2	7/8 x 5 1/2 M22 x 140	180 245	220 300	21.7 9.8
10 250	10.750 273.0	800 55.2	72,610 322.99	0-3/32 0-2.38	0° 30'	0.11 8.7	13 1/8 333	16 3/8 422	2 3/8 67	2	7/8 x 5 1/2 M22 x 140	180 245	220 300	27.0 12.2
12 300	12.750 323.9	800 55.2	102,141 454.35	0-3/32 0-2.38	0° 25'	0.09 7.3	15 1/2 394	18 3/8 473	2 3/8 67	2	7/8 x 6 M22 x 150	180 245	220 300	35.0 15.9
14 350	14.000 355.6	300 20.7	46,181 205.43	0-3/32 0-2.38	0° 23'	0.08 6.7	16 1/8 410	20 1/2 521	3 76	2	7/8 x 5 1/2 M22 x 140	180 245	220 300	37.0 16.8
16 400	16.000 406.4	300 20.7	60,319 268.31	0-3/32 0-2.38	0° 20'	0.07 5.9	18 1/8 460	22 3/8 581	3 76	4	1 x 4 *	200 -	250 -	50.0 22.7
18 450	18.000 457.2	300 20.7	76,341 339.58	0-3/32 0-2.38	0° 18'	0.06 5.2	21 1/8 537	25 3/8 645	3 1/8 79	4	1 x 4 *	200 -	250 -	72.0 32.7
20 500	20.000 508.0	300 20.7	94,248 419.23	0-3/32 0-2.38	0° 16'	0.06 4.7	23 584	28 1/4 718	3 3/8 79	4	1 1/8 x 4 1/2 *	225 -	275 -	82.0 37.2
24 600	24.000 609.6	300 20.7	135,717 603.70	0-3/32 0-2.38	0° 13'	0.05 3.9	27 686	32 3/8 822	3 3/8 79	4	1 1/8 x 4 1/2 *	225 -	275 -	90.0 40.8
28" O.D. 733.4	28.875 733.4	150 10.3	98,226 436.93	0-3/32 0-2.38	0° 11'	0.04 3.2	33 1/2 851	35 1/2 902	3 3/8 79	6	1 x 5 1/2 *	200 -	250 -	105.0 47.6
30" I.D. 787.4	31.00 787.4	150 10.3	113,215 503.61	0-3/32 0-2.38	0° 10'	0.04 3.0	33 3/4 857	38 1/4 972	3 3/8 92	6	1 x 5 1/2 *	200 -	250 -	137.0 62.1

NOTES:
Range of Pipe End Separation and Angular Deflection values are for roll grooved pipe and may be doubled for cut groove pipe. See page 204 for details. Refer to page 210 for Misalignment & Deflection Calculations and page 211 for Curve Layout Calculations.

* Available in ANSI or metric bolt sizes only as indicated.
For additional details see "Coupling Data Chart Notes" on page 17.
§ - For additional Bolt Torque information, see page 204.
See Installation & Assembly directions on page 166.
Not for use in copper systems.