

**FIG. 7004**

## Coupling



The Gruzlok Fig. 7004 is designed to provide the versatility of a grooved joint while providing a rigid pipe joint.

The Fig. 7004 coupling permits working pressure ratings up to 1000 psi (68.9 bar).

This coupling is also suited for lower pressure systems which experience pressure pulses. Systems used for high pressure, including auto and truck washes, will benefit from the increased pressure capability.

Working Pressure & End Load values are based on grooved standard wall pipe.

Fig. 7004 provides a rigid joint and does not allow for expansion or contraction. The Fig. 7004 coupling is an ideal choice for higher pressure applications such as elevator services.

**NOTE:** Fig. 7004 can be used with EG fittings as a commercial joint only.

**MATERIAL SPECIFICATIONS****ANSI BOLTS & HEAVY HEX NUTS:**

Heat treated, oval neck track head bolts conforming to ASTM A 183 Grade 2 with a minimum tensile strength of 110,000 psi and heavy hex nuts of carbon steel conforming to ASTM A 563 Grade A or Grade B, or J995 Grade 2. Bolts and nuts are provided zinc electroplated as standard.

**METRIC BOLTS & HEAVY HEX NUTS:**

Heat treated, zinc electroplated oval-neck track head bolts made of carbon steel with mechanical properties per ISO 898-1 Class 8.8. Hex nuts are zinc electroplated followed by a yellow chromate dip.

**STAINLESS STEEL BOLTS & NUTS:**

304SS Stainless Steel bolts and nuts are available as a standard option. (316SS are available for special order).

**WORKING PRESSURE, END LOAD, PIPE END SEPARATION & DEFLECTION FROM CENTER LINE:**

Based on standard wall steel pipe with cut or roll grooves in accordance with Gruzlok specifications. See technical data section for design factors.

**HOUSING:**

Ductile Iron conforming to ASTM A 536, Grade 65-45-12.

**COATINGS:**

Rust inhibiting paint – Color: Orange (standard)  
Hot Dipped Zinc Galvanized (optional)  
Other Colors Available (IE: RAL3000 and RAL9000)  
For other Coating requirements contact an Anvil Representative.

**GASKETS: Materials**

Properties as designated in accordance with ASTM D 2000

**Grade “EP” EPDM** (Green and Red color code) Standard  
-40°F to 250°F (Service Temperature Range)(-40°C to 121°C)  
Recommended for water service, diluted acids, alkalies solutions, oil-free air and many other chemical services.  
NOT FOR USE IN PETROLEUM APPLICATIONS.

For hot water applications the use of Gruzlok Extreme Temperature lubricant is recommended.

**Grade “T” Nitrile** (Orange color code)  
-20°F to 180°F (Service Temperature Range)(-29°C to 82°C)  
Recommended for petroleum applications. Air with oil vapors and vegetable and mineral oils.  
NOT FOR USE IN HOT WATER OR HOT AIR.

**Grade “O” Fluoro-Elastomer** (Blue color code)  
Size Range: 2" - 12" (C style only)  
20°F to 300°F (Service Temperature Range)(-29°C to 149°C)  
Recommended for high temperature resistance to oxidizing acids, petroleum oils, hydraulic fluids, halogenated hydrocarbons and lubricants.

**Grade “L” Silicone** (Red color code)  
Size Range: 2" - 12" (C style only)  
-40°F to 350°F (Service Temperature Range)(-40°C to 177°C)  
Recommended for dry, hot air and some high temperature chemical services.

**GASKET TYPE:**

Standard C Style (2" - 12")  
Flush Gap (2" - 12")

**LUBRICATION:**

Standard Gruzlok  
Gruzlok Xtreme™(Do Not use with Grade “L”)

**FIG. 7004**

**Coupling**

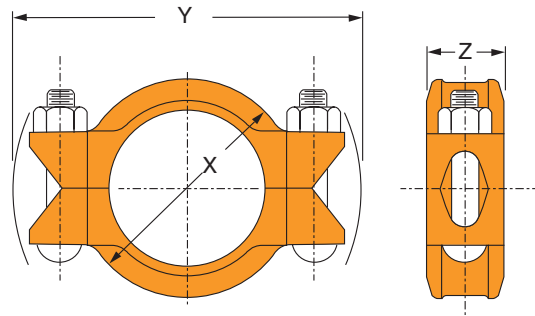

Fig. 7004 with standard gasket

FIGURE 7004 COUPLING										
Nominal Size	O.D.	Max. Wk. Pressure	Max. End Load	Range of Pipe End Separation	Coupling Dimensions			Coupling Bolts		Approx. Wt. Ea.
					X	Y	Z	Qty.	Size	
<i>In./DN(mm)</i>	<i>In./mm</i>	<i>PSI/bar</i>	<i>Lbs./kN</i>	<i>In./mm</i>	<i>In./mm</i>	<i>In./mm</i>		<i>In./mm</i>	<i>Lbs./Kg</i>	
2 50	2.375 60.3	1000 68.9	4,430 19.7	0 - 1/32 0 - 0.79	3 3/8 92	6 1/4 159	1 7/8 48	2	5/8 x 2 3/4 -	3.9 1.8
2 1/2 65	2.875 73.0	1000 68.9	6,492 28.9	0 - 1/32 0 - 0.79	4 1/4 108	6 7/8 175	1 7/8 48	2	5/8 x 3 1/2 M16 x 85	4.6 2.1
3 80	3.500 88.9	1000 68.9	9,621 42.8	0 - 1/32 0 - 0.79	4 7/8 124	7 1/2 191	1 7/8 48	2	5/8 x 3 1/2 M16 x 85	5.2 2.4
4 100	4.500 114.3	1000 68.9	15,904 70.8	0 - 3/32 0 - 2.38	6 1/4 159	9 1/2 241	2 1/4 57	2	3/4 x 4 1/2 M20 x 110	8.6 3.9
5 125	5.563 141.3	1000 68.9	24,306 108.1	0 - 3/32 0 - 2.38	7 1/2 191	11 279	2 1/4 57	2	7/8 x 5 1/2 M22 x 150	14.0 6.4
6 150	6.625 168.3	1000 68.9	34,472 153.3	0 - 3/32 0 - 2.38	8 3/4 222	12 1/8 308	2 1/4 57	2	7/8 x 5 1/2 M22 x 150	15.5 7.0
8 200	8.625 219.1	800 55.2	46,741 207.9	0 - 3/32 0 - 2.38	11 1/8 283	14 7/8 378	2 5/8 67	2	1 x 5 1/2 -	25.6 11.6
10 250	10.750 273.1	800 55.2	72,610 323.0	0 - 3/32 0 - 2.38	13 1/2 343	17 432	2 5/8 67	2	1 x 6 1/2 -	32.3 14.7
12 300	12.750 323.9	800 55.2	102,141 454.4	0 - 3/32 0 - 2.38	15 1/8 403	19 1/4 489	2 5/8 67	2	1 x 6 1/2 -	43.9 19.9

For additional details see "Coupling Data Chart Notes" on page 17. See Installation & Assembly directions on page 183. Not for use in copper systems.