



BONNEY  
FORGE  
10-300  
WCB  
140129

BONNEY  
FORGE  
8-150  
WCB  
178862

BONNEY  
FORGE  
8-150  
WCB  
178862

BONNEY  
FORGE  
4-150  
WCB  
18318

BONNEY  
FORGE  
8-150  
WCB  
178862



CAST  
STEEL  
VALVES

---



BONNEY FORGE





***SBP LIMITED***  
*A Bonney Forge Venture Company*

SBP LIMITED IS A BONNEY FORGE JOINT VENTURE COMPANY  
408 XIANGHUAQIAO ROAD (E) • QINGPU • SHANGHAI • CHINA 201707

BONNEY FORGE CORPORATE HEADQUARTERS  
MANUFACTURING/SALES CENTER/WAREHOUSE  
14496 CROGHAN PIKE • P.O. BOX 330 • MT. UNION, PA 17066  
(814) 542-2545 • (800) 231-0655  
(800) 345-7546 • FAX (814) 542-9977  
[www.bonneyforge.com](http://www.bonneyforge.com) • [bfsales@bonneyforge.com](mailto:bfsales@bonneyforge.com)



BONNEY FORGE CORPORATE HEADQUARTERS  
MT. UNION, PA



Corporate Overview .....	2, 3
Quality Assurance .....	4, 5
How To Order .....	6-8
Gate Valves .....	9-11
Globe Valves .....	12-14
Swing Check Valves .....	15-17
Engineering Specifications .....	18-29
Special Valves & Features.....	18, 19
Bypass & Drain Connection .....	20
Butt-Welding Ends.....	21
Flange Dimensions.....	22, 23
Ring Joint Facings.....	24, 25
Standard Class Pressure Temperature Ratings .....	26-28
Storage, Installation & Maintenance .....	29-34
Terms & Conditions .....	37

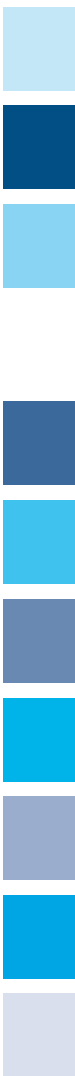

## **Bonney Forge – The Name You Can Trust for Cast Steel Valves**

For decades, Bonney Forge forged steel valves and piping components have defined “state-of-the-art” in quality, design and manufacturing. Today, our extensive product line of cast steel valves leads the way.

Since 2002, Bonney Forge has been manufacturing its Cast Steel Valves in Shanghai, China. SBP Limited – A Bonney Forge Venture Company, manufactures a full line of Cast Steel Gate, Globe and Check Valves designed for ASME pressures 150# thru 1500# and temperature ratings as low as -50°F. Our technicians can also customize a configuration to fit your needs. Bonney



## **A SINGLE-SOURCE SOLUTION**

Forge customers have a complete choice of trim and body materials, bypasses and connectors including: lift indicators, limit microswitches, pneumatic and electric actuators, bevel gearings, chain wheels, extension stems, floor stands, levers and dashpots.

SBP Limited also meets stringent design and quality guidelines set and directed by Bonney Forge’s corporate engineering department at its corporate location in Mt. Union, Pennsylvania, USA. SBP Limited has also earned the ISO 9001:2001, PED CE Mark, API 6D, and API 600 Certificates.

### **We’re Here for You**

Bonney Forge is committed to manufacturing excellence and is focused on meeting our customers’ needs. This catalog offers a vast amount of product information and specifications. In the event that you need additional information or technical assistance please call our friendly and knowledgeable customer service team at (800) 231-0655 or visit our website at [www.bonneyforge.com](http://www.bonneyforge.com).

### **Our Mission**

To be, today and in the future, the recognized leader in our industry, marketing and manufacturing forged steel valves, cast steel valves, forged fittings, branch connections and other related products to satisfy

our customer’s expectations.

To be cost effective through Total Quality performance of these operations, and thus provide the resources required to support our commitment to improve our products, processes and customer services.

To be a law abiding corporate citizen respecting the rights of individuals, contributing to the needs of the community and conserving the state of the environment.





**The Best Value -  
Price, Quality, Service  
All The Time.**



### Testing

Bonney Forge products are manufactured and tested in strict accordance to ASTM, ASME, API and other industry codes and specifications as applicable.

Material Certifications are available upon request to the applicable ASTM/ASME material specifications for all Bonney Forge Valve bodies and bonnets.

Modern machining equipment plus rigid inspection procedures of all parts assures dimensional accuracy of every part. Quality Assurance procedures include, 100% hydrostatic and pneumatic testing of all valves in full conformance to applicable API standards and industry codes.

Chemical and mechanical properties of every Bonney Forge cast steel valve are fully traceable to the original casting heat lot.

### Material Safety Data Sheets

Material Safety Data Sheets (MSDS) are required for hazardous chemicals under the Occupational Safety and Health Administration (OSHA) Hazard Communication Standard 29 CFR 1910.1200. Bonney Forge Corporation has determined that its valve and fitting products are “articles”, as defined by this standard, and therefore do not require material safety data sheets.

### Certificates

Also, SBP limited is fully qualified and maintains the ISO 9001 2001, PED CE Mark, API 6D and API 600 certifications, as indicated below.

### Manufacturing Capabilities





The SBP Limited facilities are located in Shanghai, China and are in full accordance with ISO 9001 and CE Mark certifications.







# HOW TO ORDER/SPECIFY CAST STEEL VALVES

1. Specify valve size
2. Designate Bonnet Style and Pressure Class from Section A
3. Select Valve Type desired from Section B
4. Indicate Body/Bonnet and Trim Material from Section C
5. Select End Configuration from Section D
6. Select other Body/Bonnet/Trim from Section E
7. Select Special Requirement(s) from Section F
8. Specify as a Suffix String, after Section D or E, any Body/Bonnet Material, Trim Material or Special Requirements not listed below

## SECTION A- BONNET STYLE AND PRESSURE CLASS

1	Bolted Bonnet	Class 150#
3	Bolted Bonnet	Class 300#
6	Bolted Bonnet	Class 600#
9	Bolted Bonnet	Class 900#
15	Bolted Bonnet	Class 1500#

Note: Pressure Seal Bonnet design available upon request

## SECTION B- TYPE OF VALVE

1	Gate Valve, Flexible Wedge
3	Globe Valve, T Pattern
6	Check Valve, Swing Type

## SECTION C- BODY/BONNET AND TRIM MATERIAL

1	A216WCB	Body/Bonnet, Trim 13% Cr (F6/CA15) Hard Faced Seats (1/2 Stellite) API Trim #8
1N	A216WCB	Body/Bonnet, Trim 13% Cr (F6/CA15) API Trim #1
2	A216WCB	Body/Bonnet, Trim 13% Cr (F6/CA15) Hard Faced Seats & Disc (Full Stellite) API Trim #5
3	A216WCB	Body/Bonnet, Trim 18% Cr-8Ni (316/CF8M) API Trim #12
4	A216WCB	Body/Bonnet, Trim Ni-Cu Alloy, (Monel Metal) API Trim #9
5	A217WC9	Body/Bonnet, 2 <sup>1</sup> / <sub>4</sub> % Cr 1% Mo, Trim 13% Cr (F6/CA15) Hard Faced Seats (1/2 Stellite) API Trim #8
6	A217C5	Body/Bonnet, 5% Cr 1/2 % Mo, Trim 13% Cr (F6/CA15) Hard Faced Seats (1/2 Stellite) API Trim #8
7	A351CF8	Body/Bonnet, Trim 18% Cr - 8 Ni(304/CF8) Trim 304 Stainless Steel API Trim #2
8	A351CF8M	Body/Bonnet, Trim 18% Cr - 8 Ni(316/CF8M) Trim 316 Stainless Steel API Trim #10
8S	A351CF8M	Body/Bonnet, Trim 18% Cr - 8 Ni(316/CF8M) Trim 316 Stainless Steel, Hard Faced Seats (1/2 Stellite) API Trim #12
9	A217WC6	Body/Bonnet, 1 <sup>1</sup> / <sub>4</sub> % Cr 1/2 Mo, Trim 13% Cr (F6/CA15) Hard Faced Seats (1/2 Stellite) API Trim #8
0	Other	Specify

## SECTION D- END CONFIGURATION

RF	Raised Face, Flanged End, 125-250 AARH
RTJ	Ring Type Joint
BW	Butt Weld Ends (Specify Pipe Schedule)

## SECTION E- OTHER BODY/BONNET OR TRIM MATERIALS

C12	A217C12	9% Cr 1% Moly Steel
CA15	A217CA15	13% Cr 1/2 Moly Steel
LCB/LCC	A352LCB	Low Temp Carbon Steel - 50° F
CF3	A351CF3	Stainless Steel, Type 304L

Note: Other body/bonnet/trim materials available upon request





BONNEY FORGE

# HOW TO ORDER/SPECIFY CAST STEEL VALVES

## SECTION E- AVAILABLE TRIM MATERIALS

TRIM												
API 600 TRIM No.		1	2	5	6	8	9	10	12	13	15	16
Seating Surface	Wedge – Check Disc	F6	F304	Stellite	F6	F6	Monel	F316	F316	ALLOY 20	Stellite	Stellite
	Seat Ring				Monel	Stellite			Stellite			
	Globe Disc				F6	F6			F316			
	Seat Ring				Monel	Stellite			Stellite			
Back Seat				F6	F6	F6			F316		F304	F316
Stem – Hinge Pin												

## SECTION F- MODIFICATIONS/SPECIAL REQUIREMENTS

- BG Bevel Gear Operator
- BYP Bypass
- CWO Chainwheel Operated
- CRY Cryogenic Bonnet
- EMO Electric Motor Operator
- GD Guided Disc (Globe Valves)
- NACE NACE Requirements to MR-01-03, latest edition
- PMI Positive Material Identification required

List as a suffix, by abbreviation if possible, any other requirement not shown on this list

Example: 3" 150# RF Flanged Gate Valve, Bolted Bonnet, ASTM A216WCB Body/Bonnet with 1/2 Stellite Trim

<u>1</u>	<u>11</u>	<u>RF</u>
Sec A	Sec. B, Sec. C	Sec. D

AS: 3" 1-11-RF



# GATE VALVES - CLASS 150

BONNEY FORGE

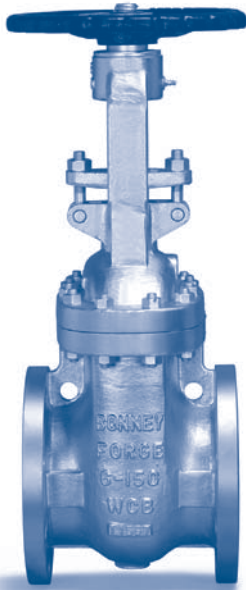

**Design construction:**

API 600, ASME B16.34  
 Pressure – Temperature Rating ASME B16.34  
 Face to Face / End to End ASME B16.10  
 Connection ASME B16.5 / B16.25  
 Testing and Inspection API 598

MATERIALS OF CONSTRUCTION		
ITEM	DESCRIPTION	MATERIAL
1	Body	A216 WCB
2	Seat Ring	A105 + Stellite
3	Wedge	A216 WCB / 13% CR.
4	Stem	A182 F6
5	Bonnet Bolt	A193 B7
6	Bonnet Nut	A194 2H
7	Gasket	316 Graphite Corrugated
8	Bonnet	A216 WCB
9	Back Seat	A182 F6
10	Packing	Graphite
11	Eye Bolt Pin	Steel
12	Gland Eye Bolt	A193 GR. B7
13	Packing Gland	A182 F6a
14	Flange Gland	A216 WCB
15	Eye Bolt Nut	A194 GR 2H
16	Grease Nipple	Steel
17	Yoke Sleeve	A439 GR D2
18	Sleeve Nut	Steel
19	Handwheel	Ductile Iron
20	Handwheel Nut	Steel
21	Set Screw	Steel
22	Yoke	A216 WCB
23	Yoke Nut	A194 GR. 2H
24	Yoke Bolt	A193 GR B7
25	Bearing	Steel

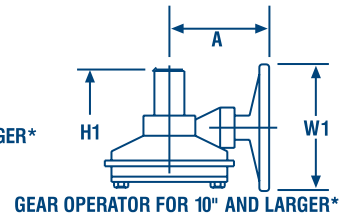
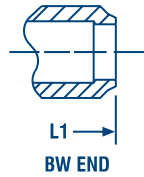

\* When requested

DIMENSIONAL SPECIFICATIONS															
SIZE	inch mm	2 50	2.5 65	3 80	4 100	5 130	6 150	8 200	10 250	12 300	14 350	16 400	18 450	20 500	24 600
L	inch mm	7.00 177.80	7.50 190.50	8.00 203.20	9.00 228.60	10.00 254.00	10.50 266.70	11.5 292.10	13.00 330.20	14.00 355.60	15.00 381.00	16.00 406.40	17.00 431.80	18.00 457.20	20.00 508.00
L1	inch mm	8.50 215.90	9.50 241.30	11.12 282.45	12.00 304.80	15.00 381.00	15.88 403.35	16.50 419.10	18.00 457.20	19.75 501.65	22.50 571.50	24.00 609.60	26.00 660.40	28.00 711.20	32.00 812.80
L2	inch mm	7.50 190.50	8.00 203.20	8.50 215.90	9.50 241.30	10.50 266.70	11.00 279.40	12.00 304.80	13.50 342.90	14.50 368.30	15.50 393.70	16.50 419.10	17.50 444.50	18.50 469.90	20.50 520.70
W	inch mm	8 200	8 200	10 250	10 250	10 250	12 300	14 350	16 400	20 500	20 500	24 600	25 640	26 650	30 750
W1	inch mm	-	-	-	-	-	-	12.0 305	12.2 305	12.2 305	12.2 305	12.2 310	18.1 460	18.1 460	18.1 460
H (OPEN)	inch mm	16.65 423	19.50 495	20.50 520	23.50 596	28.00 711	29.80 759	39.00 995	26.50 1180	56.00 1432	60.50 1535	71.30 1811	79.00 2009	87.80 2230	104.00 2641
H1 (GEAR)	inch mm	-	-	-	-	-	-	42.13 1070	50.75 1289	59.41 1509	63.54 1614	72.44 1840	79.21 2012	85.83 2180	100.79 2560
A	inch mm	-	-	-	-	-	-	8.66 220	8.66 220	8.66 220	14.17 360	14.17 360	14.17 360	16.18 411	16.18 411
WT (RF)	lb kg	47 21	62 28	80 36	118 53	133 60	187 84	309 139	447 201	711 320	956 430	1218 548	1653 744	2482 1117	3258 1466
WT (BW)	lb kg	40 18	47 21	67 30	98 44	120 54	169 76	280 126	398 179	673 303	884 398	1131 509	1578 710	2393 1077	3169 1426
WT (RF & GD)	lb kg	-	-	-	-	-	-	358 161	496 223	760 342	1000 450	1262 568	1720 774	2549 1147	3324 1496
WT (BW & GD)	lb kg	-	-	-	-	-	-	329 148	447 201	722 325	929 418	1176 529	1644 740	2460 1107	3236 1456
CV Factors		-	410	710	1300	-	3110	5720	8935	13350	-	21560	36091	47615	67862





BONNEY FORGE

# GATE VALVES - CLASS 300

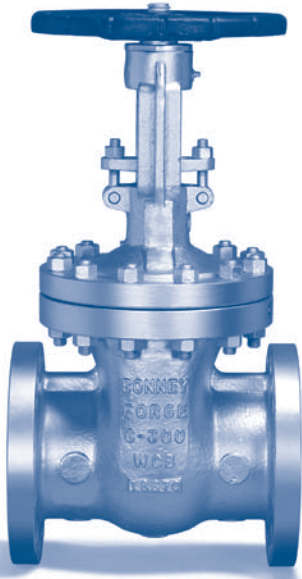

**Design construction:**

API 600, ASME B16.34  
 Pressure – Temperature Rating ASME B16.34  
 Face to Face / End to End ASME B16.10  
 Connection ASME B16.5 / B16.25  
 Testing and Inspection API 598

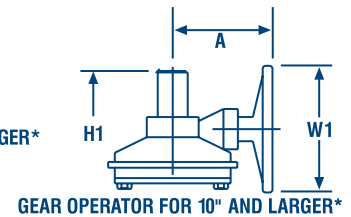
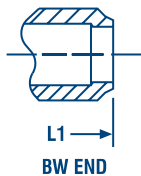
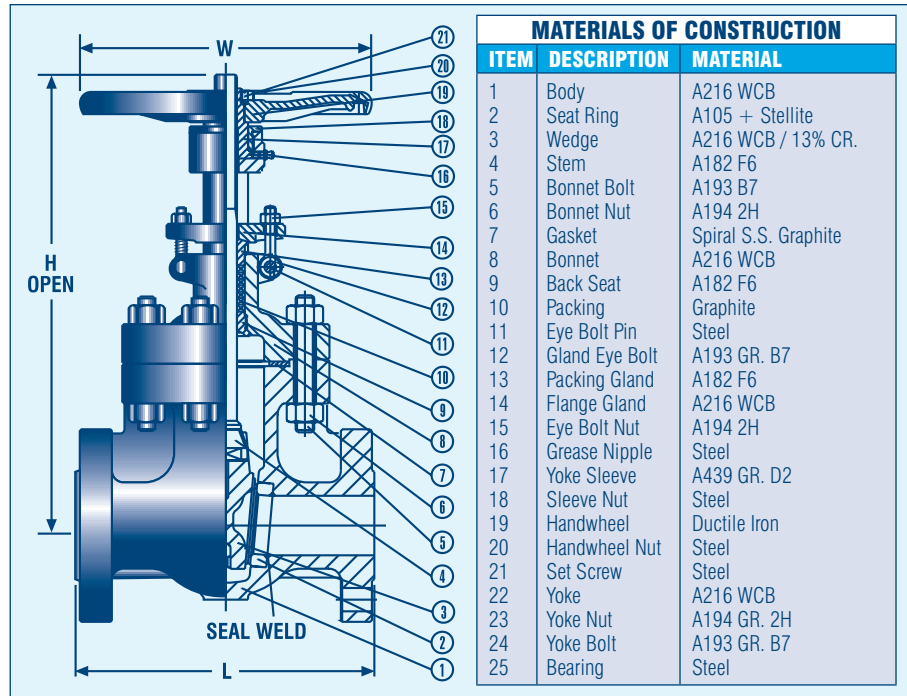

\* When requested

DIMENSIONAL SPECIFICATIONS		2	2.5	3	4	5	6	8	10	12	14	16	18	20	24
SIZE	inch mm	50	65	80	100	130	150	200	250	300	350	400	450	500	600
L	inch	8.50	9.50	11.12	12.00	15.00	15.88	16.50	18.00	19.75	30.00	33.00	36.00	39.00	45.00
	mm	215.90	241.30	282.45	304.80	381.00	403.35	419.10	457.20	501.65	762.00	838.20	914.40	990.60	1143.00
L1	inch	8.50	9.50	11.12	12.00	15.00	15.88	16.50	18.00	19.75	30.00	33.00	36.00	39.00	45.00
	mm	215.90	241.30	282.45	304.80	381.00	403.35	419.10	457.20	501.65	762.00	838.20	914.40	990.60	1143.00
L2	inch	9.12	10.12	11.75	12.62	15.62	16.5	17.12	18.62	20.37	30.62	33.62	36.62	39.75	45.88
	mm	231.65	257.05	298.45	320.55	396.75	419.10	434.85	472.95	517.40	777.75	853.95	930.15	1009.65	1165.35
W	inch	8	8	10	10	14	14	16	18	20	25	25	27	30	35
	mm	200	200	250	250	350	350	400	450	500	640	640	680	760	900
W1	inch	-	-	-	-	-	12	12	12	18	18	18	21	21	24
	mm	-	-	-	-	-	305	305	305	460	460	460	540	540	610
H (OPEN)	inch	16.93	20.67	21.85	24.41	31.10	31.69	39.57	48.43	57.68	62.01	69.21	77.72	85.31	111.69
	mm	430	525	555	620	790	805	1005	1230	1465	1575	1758	1974	2167	2837
H1 (GEAR)	inch	-	-	-	-	-	32.87	40.75	50.08	58.23	64.17	71.46	79.17	87.60	105.00
	mm	-	-	-	-	-	835	1035	1272	1479	1630	1815	2011	2225	2667
A	inch	-	-	-	-	-	8.66	8.66	8.66	10.51	14.17	14.17	14.17	16.18	16.18
	mm	-	-	-	-	-	220	220	220	267	360	360	360	411	411
WT (RF)	lb	62.22	80.00	113.33	173.33	237.78	320.00	506.67	711.11	1000.00	1542.22	2400.00	2744.44	3677.78	5155.56
	kg	28	36	51	78	107	144	228	320	450	694	1080	1235	1655	2320
WT (BW)	lb	48.89	60.00	88.89	133.33	191.11	251.11	406.67	564.44	795.56	1280.00	2077.78	2342.22	3184.44	4364.44
	kg	22	27	40	60	86	113	183	254	358	576	935	1054	1433	1964
WT (RF & GO)	lb	-	-	-	-	-	368.89	555.56	760.00	1066.67	1904.44	2604.44	3295.56	4113.33	5853.33
	kg	-	-	-	-	-	166	250	342	480	857	1172	1483	1851	2634
WT (BW & GO)	lb	-	-	-	-	-	300.00	455.56	613.33	862.22	1642.22	2282.22	2893.33	3620.00	5062.22
	kg	-	-	-	-	-	135	205	276	388	739	1027	1302	1629	2278
CV Factors	-	-	410	710	1300	-	3110	5720	8935	13350	-	21560	36091	47615	67862



# GATE VALVES - CLASS 600

BONNEY FORGE

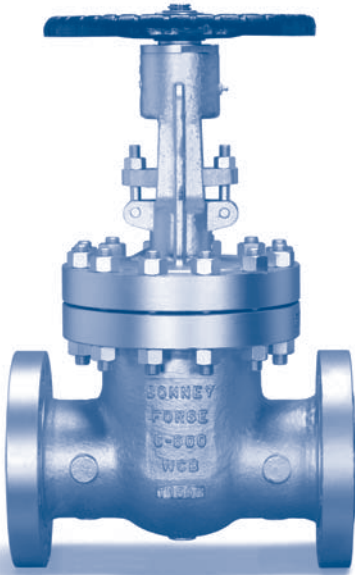

### Design construction:

API 600, ASME B16.34  
 Pressure – Temperature Rating ASME B16.34  
 Face to Face / End to End ASME B16.10  
 Connection ASME B16.5 / B16.25  
 Testing and Inspection API 598

MATERIALS OF CONSTRUCTION		
ITEM	DESCRIPTION	MATERIAL
1	Body	A216 WCB
2	Seat Ring	A105 + Stellite
3	Wedge	A216 WCB / 13% CR.
4	Stem	A182 F6
5	Bonnet Bolt	A193 B7
6	Bonnet Nut	A194 2H
7	Gasket	Soft Iron
8	Bonnet	A216 WCB
9	Back Seat	A182 F6
10	Packing	Graphite
11	Eye Bolt Pin	Steel
12	Gland Eye Bolt	A193 GR. B7
13	Packing Gland	A182 F6
14	Flange Gland	A216 WCB
15	Eye Bolt Nut	A194 2H
16	Grease Nipple	Steel
17	Yoke Sleeve	A439 GR. D2
18	Sleeve Nut	Steel
19	Handwheel	Ductile Iron
20	Handwheel Nut	Steel
21	Set Screw	Steel
22	Yoke	A216 WCB
23	Yoke Nut	A194 GR. 2H
24	Yoke Bolt	A193 GR. B7
25	Bearing	Steel

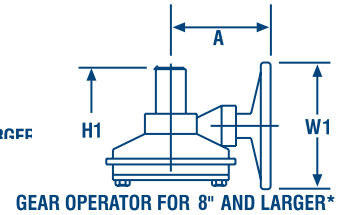
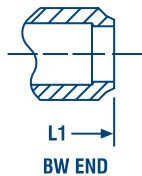

\* When requested

DIMENSIONAL SPECIFICATIONS									
SIZE	inch mm	2 50	2.5 65	3 80	4 100	5 130	6 150	8 200	10 250
L	inch mm	11.50 292.10	13.00 330.20	14.00 355.60	17.00 431.80	20.00 508.00	22.00 558.80	26.00 660.40	31.00 787.40
L1	inch mm	11.50 292.10	13.00 330.20	14.00 355.60	17.00 431.80	20.00 508.00	22.00 558.80	26.00 660.40	31.00 787.40
L2	inch mm	11.62 295.15	13.12 333.25	14.12 358.65	17.12 435.85	20.12 511.05	22.12 561.85	26.12 663.45	31.12 790.45
W	inch mm	10 250	10 250	10 250	14 350	16 400	18 450	20 500	24 600
W1	inch mm	-	-	-	-	-	12 305	18 460	24 610
H (OPEN)	inch mm	18.31 465	20.94 532	21.85 555	26.97 685	31.30 795	35.83 910	45.08 1145	49.92 1268
H1 (GEAR)	inch mm	-	-	-	-	-	45.47 1155	46.26 1175	52.36 1330
A	inch mm	-	-	-	-	-	9.45 240	10.24 260	12.60 320
WT (RF)	lb kg	91.11 41	126.67 57	160.00 72	284.44 128	444.44 200	591.11 266	931.11 419	1675.56 754
WT (BW)	lb kg	75.56 34	104.44 47	128.89 58	220.00 99	344.44 155	464.44 209	746.67 336	1368.89 616
WT (RF & GO)	lb kg	-	-	-	-	-	640.00 288	997.78 449	1786.67 804
WT (BW & GO)	lb kg	-	-	-	-	-	513.33 231	813.33 366	1480.00 666
CV Factors		-	390	561	1235	-	3406	6761	10565





BONNEY FORGE

# GLOBE VALVES - CLASS 150

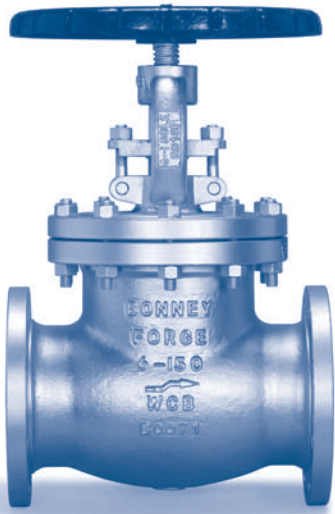

**Design construction:**

ASME B16.34  
 Pressure – Temperature Rating ASME B16.34  
 Face to Face / End to End ASME B16.10  
 Connection ASME B16.5 / B16.25  
 Testing and Inspection API 598

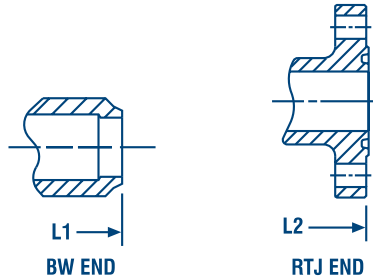
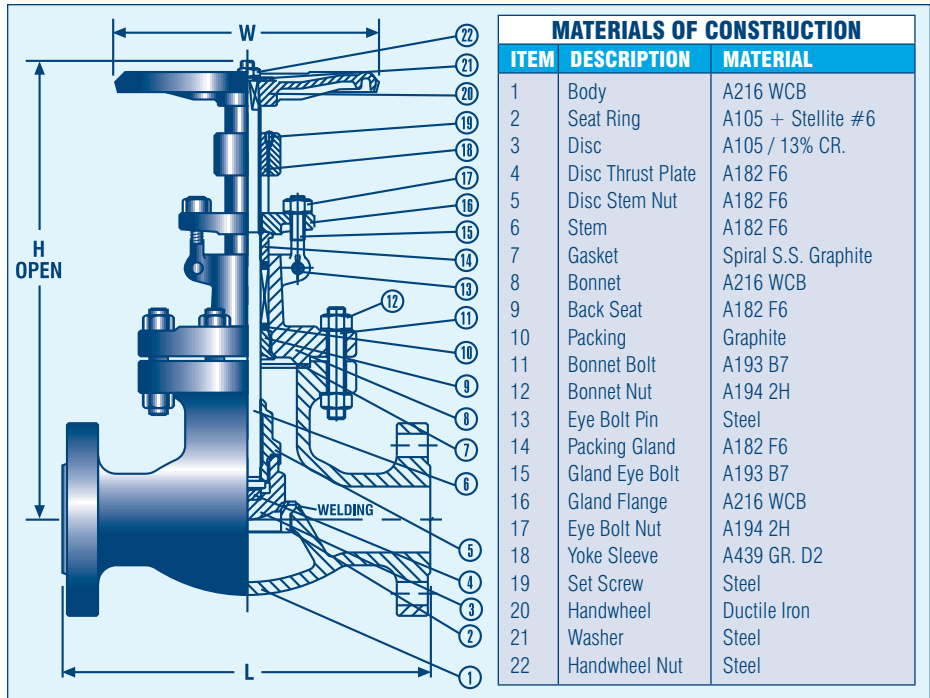

\* When requested

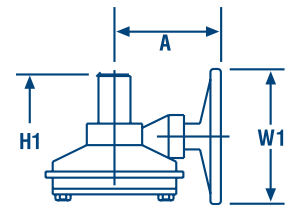

GEAR OPERATOR FOR 8" AND LARGER\*

DIMENSIONAL SPECIFICATIONS										
SIZE	inch mm	2 50	2.5 65	3 80	4 100	5 130	6 150	8 200	10 250	12 300
L	inch mm	8.00 203.20	8.50 215.90	9.50 241.30	11.50 292.10	14.00 355.60	16.00 406.40	19.50 495.30	24.50 622.30	27.50 698.50
L1	inch mm	8.00 203.20	8.50 215.90	9.50 241.30	11.50 292.10	14.00 355.60	16.00 406.40	19.50 495.30	24.50 622.30	27.50 698.50
L2	inch mm	8.50 215.90	9.00 228.60	10.00 254.00	12.00 304.80	14.50 368.30	16.50 419.10	20.00 508.00	25.00 635.00	28.00 711.20
W	inch mm	8 200	10 250	10 250	12 300	14 350	16 400	18 450	18 450	25 640
W1	inch mm	-	-	-	-	-	12 305	18 460	18 460	18 460
H (OPEN)	inch mm	14.02 356	16.54 420	16.18 411	18.70 475	21.26 540	21.65 550	24.21 615	29.49 749	36.30 922
H1 (GEAR)	inch mm	-	-	-	-	-	22.83 580	21.93 557	26.34 669	33.86 860
A	inch mm	-	-	-	-	-	9.45 240	14.17 360	14.17 360	14.17 360
WT (RF)	lb kg	46.67 21	66.67 30	82.22 37	126.67 57	173.33 78	222.22 100	346.67 156	580.00 261	684.44 308
WT (BW)	lb kg	37.78 17	48.89 22	64.44 29	102.22 46	148.89 67	191.11 86	297.78 134	504.44 227	604.44 272
WT (RF & GD)	lb kg	-	-	-	-	-	271.11 122	357.78 161	684.44 308	988.89 445
WT (BW & GD)	lb kg	-	-	-	-	-	240 108	353.33 159	608.89 274	908.89 409
CV Factors		-	80	110	185	-	440	830	1035	2065



BONNEY FORGE

# GLOBE VALVES - CLASS 300



**Design construction:**

ASME B16.34  
 Pressure – Temperature Rating ASME B16.34  
 Face to Face / End to End ASME B16.10  
 Connection ASME B16.5 / B16.25  
 Testing and Inspection API 598

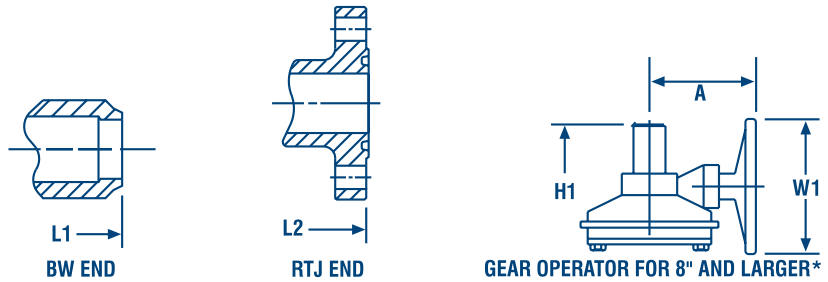
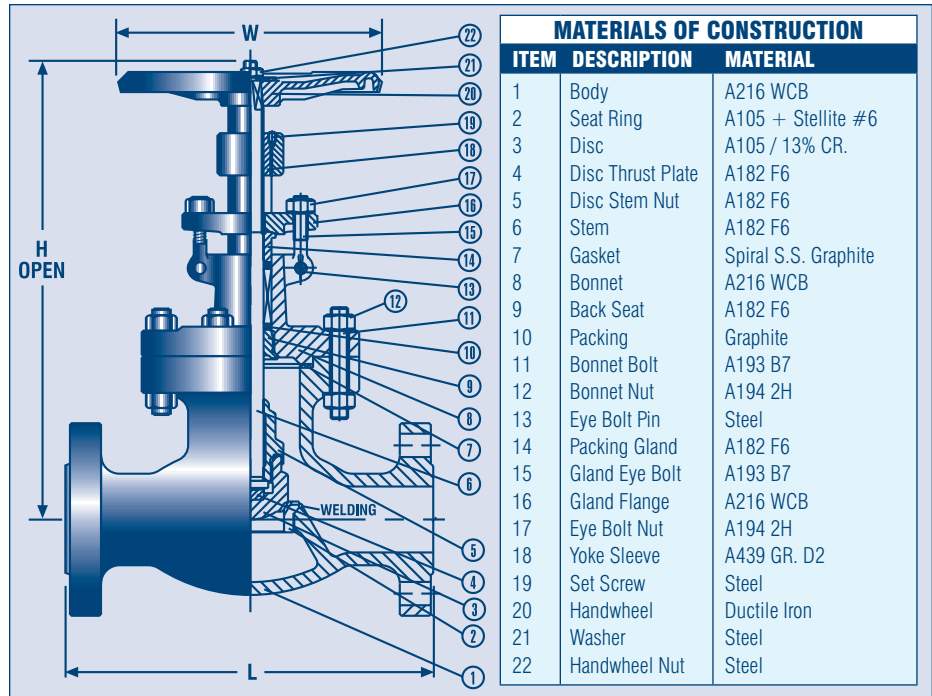

\* When requested

DIMENSIONAL SPECIFICATIONS									
SIZE	inch mm	2 50	2.5 65	3 80	4 100	5 130	6 150	8 200	10 250
L	inch mm	10.50 266.70	11.50 292.10	12.50 317.50	14.00 355.60	15.75 400.05	17.50 444.50	21.00 533.40	24.50 622.30
L1	inch mm	10.50 266.70	11.50 292.10	12.50 317.50	14.00 355.60	15.75 400.05	17.50 444.50	22.00 558.80	24.50 622.30
L2	inch mm	11.12 282.45	12.12 307.85	13.12 333.25	14.62 371.35	16.37 415.80	18.12 460.25	22.62 574.55	25.12 638.05
W	inch mm	8 200	10 250	12 300	14 350	16 400	18 450	20 500	24 610
W1	inch mm	-	-	12 305	12 305	-	12 305	18 460	24 610
H (OPEN)	inch mm	15.12 384	18.11 460	17.72 450	20.28 515	22.44 570	24.33 618	29.13 740	41.30 1049
H1 (GEAR)	inch mm	-	--	18.90 480	21.46 545	-	25.51 648	30.31 770	42.44 1078
A	inch mm	-	-	9.45 240	9.45 240	-	9.45 240	14.17 360	16.18 411
WT (RF)	lb kg	68.89 31	97.78 44	122.22 55	186.67 84	244.44 110	333.33 150	500.00 225	855.56 385
WT (BW)	lb kg	55.56 25	77.78 35	102.22 46	168.89 76	220.00 99	264.44 119	400.00 180	731.11 329
WT (RF & GD)	lb kg	-	-	171.11 77	235.56 106	-	382.22 172	566.67 255	1333.33 600
WT (BW & GD)	lb kg	-	-	151.11 68	217.78 98	-	313.33 141	466.67 210	1186.67 534
CV Fac- tors		-	80	100	185	-	440	830	1305



BONNEY FORGE

# GLOBE VALVES - CLASS 600

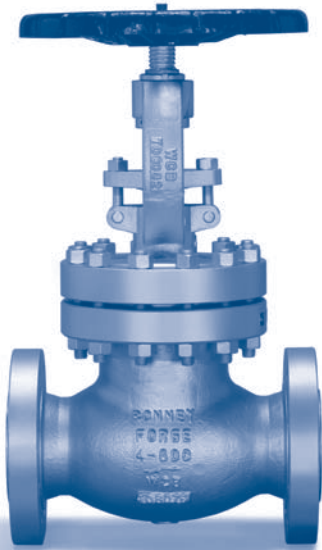

**Design construction:**

ASME B16.34  
 Pressure – Temperature Rating ASME B16.34  
 Face to Face / End to End ASME B16.10  
 Connection ASME B16.5 / B16.25  
 Testing and Inspection API 598

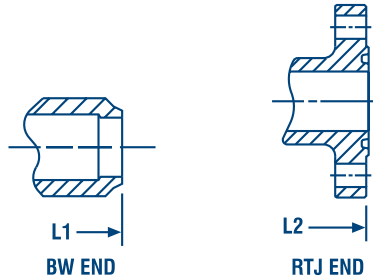
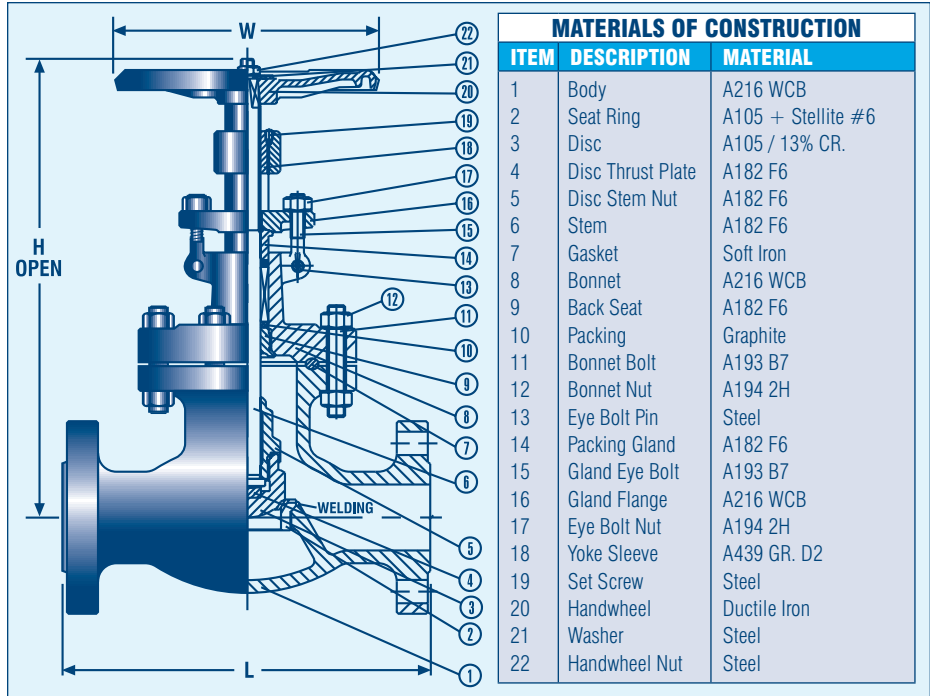

\* When requested

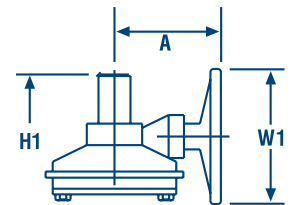

GEAR OPERATOR FOR 8" AND LARGER\*

DIMENSIONAL SPECIFICATIONS								
SIZE	inch mm	2 50	2.5 65	3 80	4 100	5 130	6 150	8 200
L	inch mm	11.50 292.10	13.00 330.20	14.00 355.60	17.00 431.80	20.00 508.00	22.00 558.80	26.00 660.40
L1	inch mm	11.50 292.10	13.00 330.20	14.00 355.60	17.00 431.80	20.00 508.00	22.00 558.80	26.00 660.40
L2	inch mm	11.62 295.15	13.12 333.25	14.12 358.65	17.12 434.85	20.12 511.05	22.12 561.85	26.12 663.45
W	inch mm	10 250	12 300	14 350	16 400	20 500	22 560	-
W1	inch mm	-	-	-	12 305	-	18 460	24 610
H (OPEN)	inch mm	17.83 453	21.50 546	22.17 563	25.91 658	28.15 715	31.02 788	-
H1 (GEAR)	inch mm	-	-	-	27.09 688	-	34.25 870	37.01 940
A	inch mm	-	-	-	9.45 240	-	9.45 240	16.26 413
WT (RF)	lb kg	100.00 45	142.22 64	173.33 78	300.00 135	471.11 212	726.67 327	-
WT (BW)	lb kg	84.44 38	120.00 54	142.22 64	235.56 106	348.89 157	580.00 261	-
WT (RF & GD)	lb kg	-	-	-	348.89 157	-	926.67 417	1204.44 542
WT (BW & GD)	lb kg	-	-	-	284.44 128	-	800.00 360	1020.00 459
CV Factors		-	100	153	263	-	513	882





BONNEY FORGE

# CHECK VALVES - CLASS 150



**Design construction:**

ASME B16.34  
 Pressure – Temperature Rating ASME B16.34  
 Face to Face / End to End ASME B16.10  
 Connection ASME B16.5 / B16.25  
 Testing and Inspection API 598

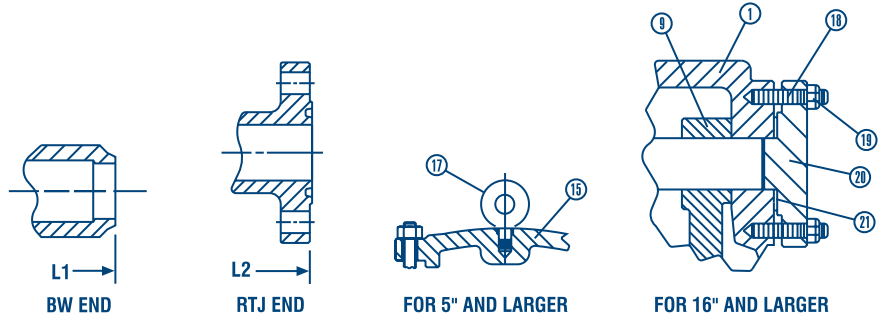
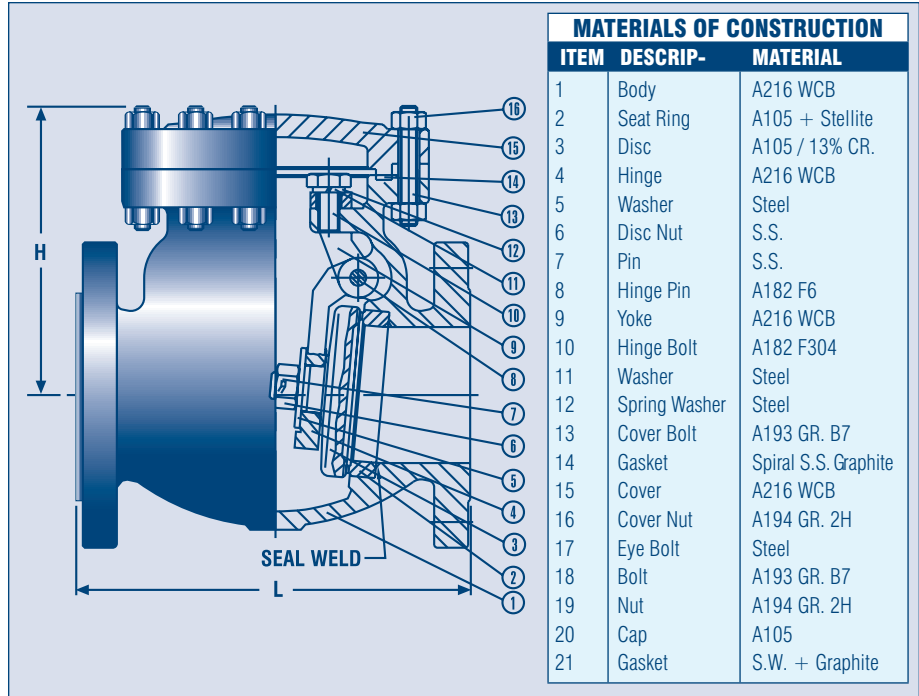

DIMENSIONAL SPECIFICATIONS												
SIZE	inch mm	2 50	2.5 65	3 80	4 100	5 130	6 150	8 200	10 250	12 300	14 350	16 400
<b>L</b>	inch mm	8.00 203.20	8.50 215.90	9.50 241.30	11.50 292.10	13.00 330.20	14.00 355.60	19.50 495.30	24.50 622.30	27.50 698.50	31.00 787.40	34.00 863.60
<b>L1</b>	inch mm	8.00 203.20	8.50 215.90	9.50 241.30	11.50 292.10	13.00 330.20	14.00 355.60	19.50 495.30	24.50 622.30	27.50 698.50	31.00 787.40	34.00 863.60
<b>L2</b>	inch mm	8.50 215.90	9.00 228.60	10.00 254.00	12.00 304.80	13.50 342.90	14.50 368.30	20.00 508.00	25.00 635.00	28.00 711.20	31.50 800.10	34.50 876.30
<b>H</b>	inch mm	6.30 160	6.57 167	7.10 180	8.54 217	11.22 285	12.40 315	14.37 365	17.52 445	20.08 510	20.94 532	22.95 583
<b>WT (RF)</b>	lb kg	42.22 19	53.33 24	62.22 28	106.67 48	140.00 63	175.56 79	288.89 130	444.44 200	666.67 300	1002.22 451	1235.56 556
<b>WT (BW)</b>	lb kg	33.33 15	44.44 20	51.11 23	93.33 42	113.33 51	148.89 67	262.22 118	360.00 162	524.44 236	715.56 322	1042.22 469
<b>CV Factors</b>		-	246	356	620	-	1414	2370	3300	4000	-	7900



BONNEY FORGE

# CHECK VALVES - CLASS 300



**Design construction:**

ASME B16.34  
 Pressure – Temperature Rating ASME B16.34  
 Face to Face / End to End ASME B16.10  
 Connection ASME B16.5 / B16.25  
 Testing and Inspection API 598

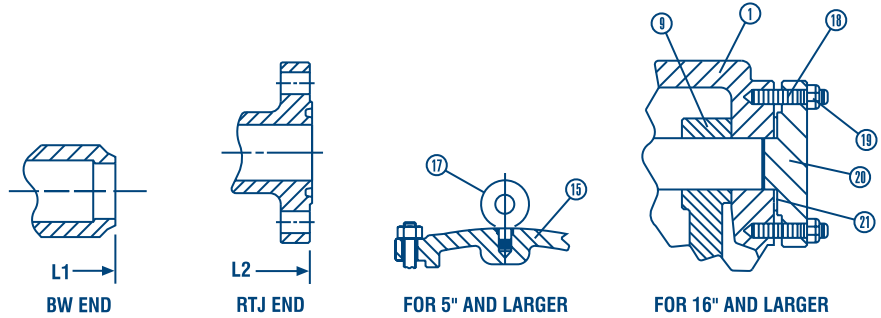
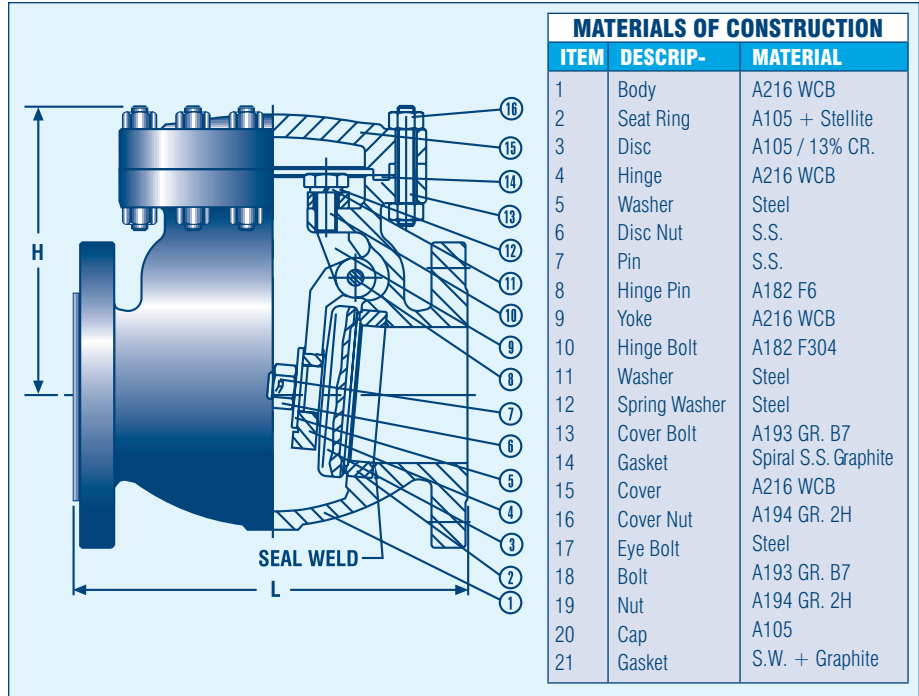

DIMENSIONAL SPECIFICATIONS										
SIZE	inch mm	2 50	2.5 65	3 80	4 100	5 130	6 150	8 200	10 250	12 300
L	inch mm	10.50 266.70	11.50 292.10	12.50 317.50	14.00 355.60	15.75 400.05	17.50 444.50	22.00 558.80	24.50 622.30	28.00 711.20
L1	inch mm	10.50 266.70	11.50 292.10	12.50 317.50	14.00 355.60	15.75 400.05	17.50 444.50	22.00 558.80	24.50 622.30	28.00 711.20
L2	inch mm	11.12 282.45	12.12 307.85	13.12 333.25	14.62 371.35	16.37 415.80	18.12 460.25	21.62 549.15	25.12 638.05	28.62 726.95
H	inch mm	7.68 195	8.27 210	8.86 225	10.63 270	12.20 310	12.99 330	15.55 395	18.31 465	18.98 482
WT (RF)	lb kg	68.89 31	86.67 39	100.00 45	151.11 68	200.00 90	302.22 136	488.89 220	700.00 315	997.78 449
WT (BW)	lb kg	57.78 26	68.89 31	82.22 37	113.33 51	148.89 67	244.44 110	386.67 174	451.11 203	853.33 384
CV Factors		-	227	329	680	-	1950	2400	3340	4000



BONNEY FORGE

# CHECK VALVES - CLASS 600



**Design construction:**

ASME B16.34  
 Pressure – Temperature Rating ASME B16.34  
 Face to Face / End to End ASME B16.10  
 Connection ASME B16.5 / B16.25  
 Testing and Inspection API 598

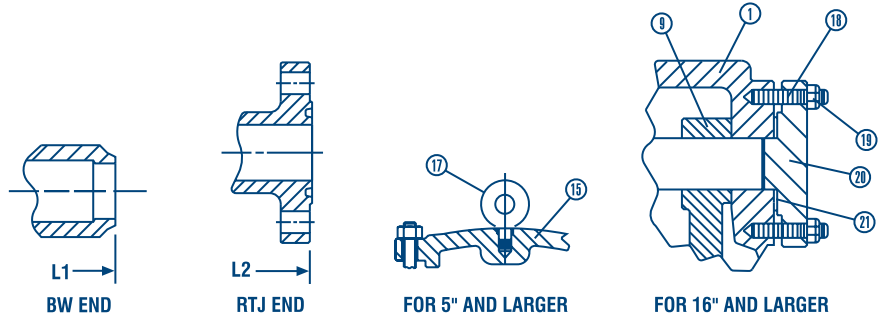
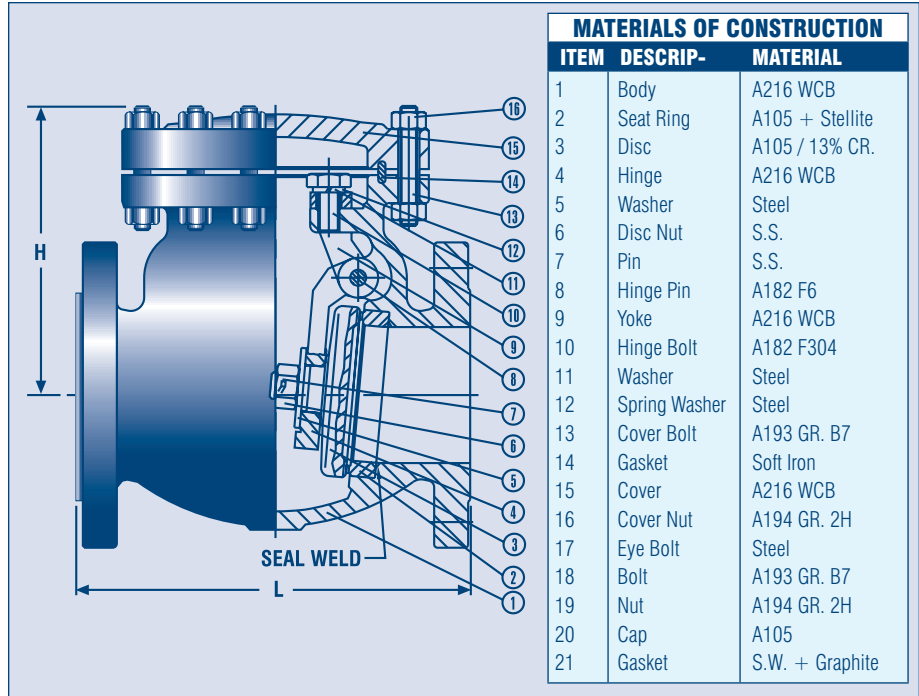

DIMENSIONAL SPECIFICATIONS										
SIZE	inch mm	2 50	2.5 65	3 80	4 100	5 130	6 150	8 200	10 250	12 300
L	inch mm	11.50 292.10	13.00 330.20	14.00 355.60	17.00 431.80	20.00 508.00	22.00 558.80	26.00 660.40	31.00 787.40	33.00 838.20
L1	inch mm	11.50 292.10	13.00 330.20	14.00 355.60	17.00 431.80	20.00 508.00	22.00 558.80	26.00 660.40	31.00 787.40	33.00 838.20
L2	inch mm	11.62 295.15	13.12 333.25	14.12 358.65	17.12 434.85	20.12 511.05	22.12 561.85	26.12 663.45	31.12 790.45	33.12 841.25
H	inch mm	7.09 180	7.76 197	11.22 285	12.80 325	13.50 343	14.80 376	20.94 532	22.95 583	23.94 608
WT (RF)	lb kg	71.11 32	93.33 42	133.33 60	244.44 110	357.78 161	491.11 221	768.89 346	1395.56 628	1768.89 796
WT (BW)	lb kg	53.33 24	73.33 33	108.89 49	182.22 82	282.22 127	404.44 182	646.67 291	1106.67 498	1535.56 691
CV Factors		-	213	308	679	-	1873	2400	3340	5045





BONNEY FORGE

# ENGINEERING SPECIFICATIONS

## SPECIAL FEATURES

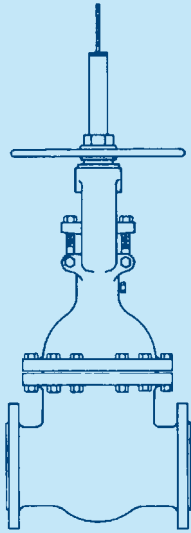

**LIFT  
INDICATOR**

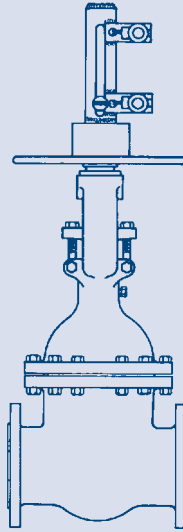

**LIMIT MICRO  
SWITCHES**

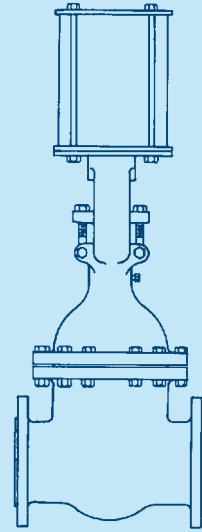

**PNEUMATIC  
OPERATOR**

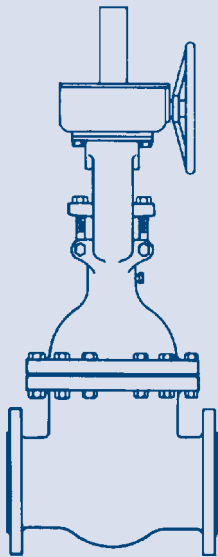

**BEVEL  
GEARING**

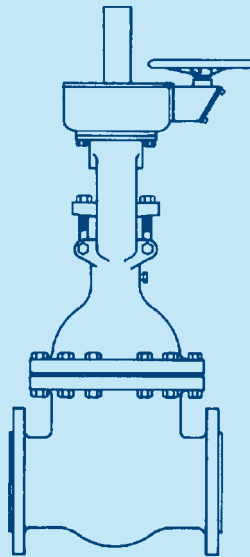

**BEVEL GEARING WITH  
HORIZONTAL HANDWHEEL**

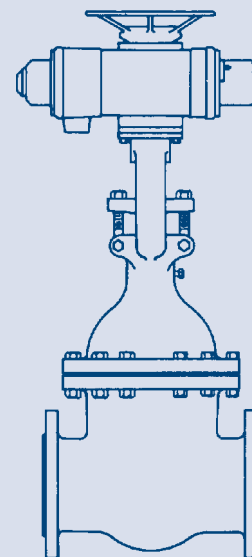

**ELECTRIC  
ACTUATOR**

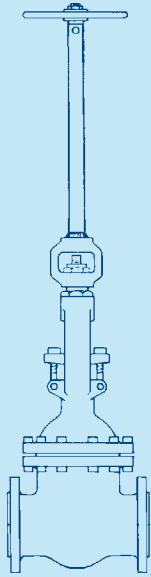

**EXTENSION  
STEM**

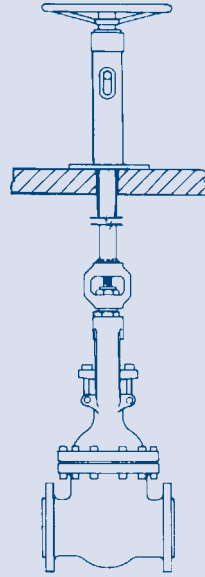

**FLOOR  
STAND**

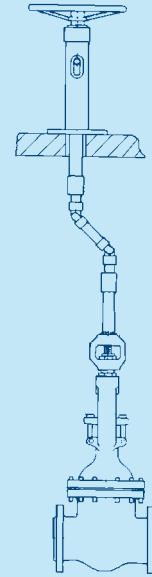

**FLOOR STAND WITH  
UNIVERSAL JOINT**

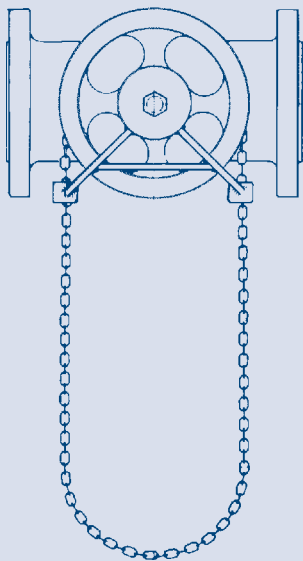

**CHAIN  
WHEEL**

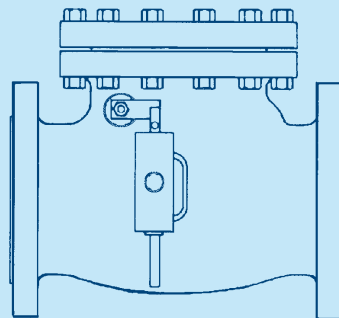

**CHECK VALVE  
WITH DASH POT**

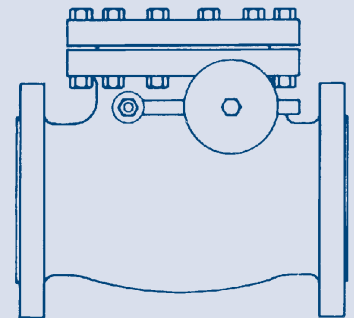

**CHECK VALVE WITH  
OUTSIDE LEVER & WEIGHT**



BONNEY FORGE

# ENGINEERING SPECIFICATIONS

## BYPASS & DRAIN CONNECTION

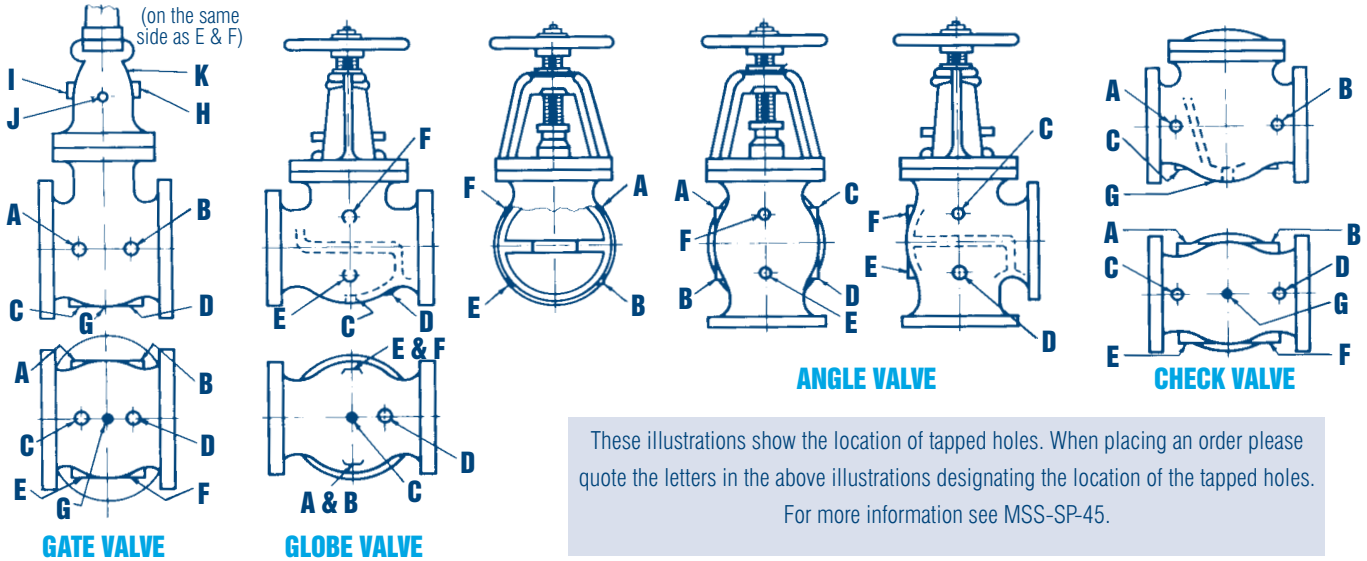

## DRAIN & BYPASS DIMENSIONS

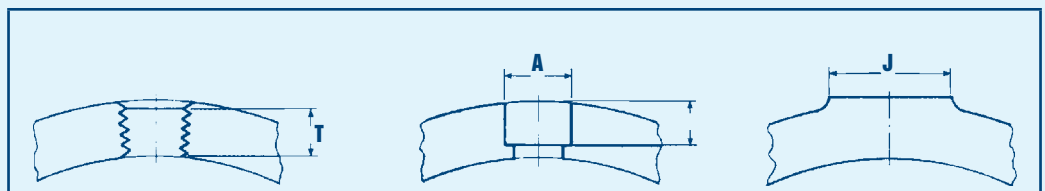

	THREAD FOR CONNECTION TAPPING	SOCKET WELDING FOR CONNECTIONS	BOSSES FOR CONNECTIONS	
<b>Size of Valve</b>		2" to 4"	5" to 8"	10" to 24"
<b>Size of Tapping</b>		1/2	3/4	1
<b>Length of Thread</b>	T	9/16	9/16	11/16
<b>Minimum Diameter of Socket</b>	A	7/8	1 1/16	1 5/16
<b>Minimum Depth of Socket</b>	B	3/16	1/4	1/4
<b>Diameter of Boss</b>	J	1 1/2	1 3/4	2 1/8

All dimensions given in inches

Bonney Forge valves can be equipped with by-passes which permit equalization of pressure on both sides of the valve. Unless otherwise specified the by-pass arrangement will be furnished on the side of the main valve. By-passes of other types can be made to order. Inquiries should give complete description or drawings.

By-pass valves are "Bonney Forge" forged steel bolted-bonnet, outside screw and yoke, socket-weld end globe valves, and materials are suitable for the same service as the main valve.





BONNEY FORGE

# ENGINEERING SPECIFICATIONS

## BUTT-WELDING ENDS

ASME B 16.25

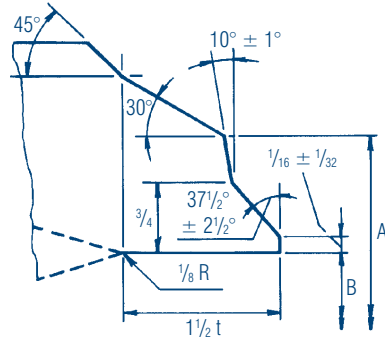
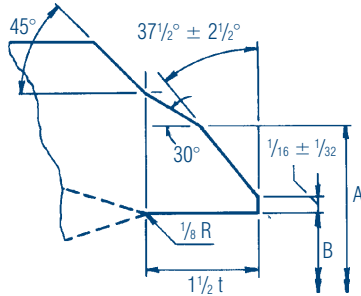

Figures refer to  
**ASME B 16-25**

**IMPORTANT:** When ordering butt welding end valves please state the type of ends required and give the pipe dimensions or schedule number.

STD = Standard Wall Thickness  
XS = Extra Strong Wall Thickness  
XXS = Double Extra Strong Wall Thickness

All dimensions given in inches  
Designations per ASME B 16.25

Nominal Pipe Size	Nominal Pipe OD	Schedule Number	Valve OD A	Nominal ID B	Wall Thickness of Pipe T
2 / 12	2.875	40	2.875	0.203	2.469
		80		0.276	2.0323
		160		0.375	2.125
		XXS		0.552	1.771
3	3.500	40	3 19/32	0.216	3.068
		80		0.300	2.900
		160		0.438	2.624
		XXS		0.600	2.300
4	4.500	40	4 5/8	0.237	4.026
		80		0.337	3.826
		120		0.438	3.624
		160		0.531	3.438
5	5.563	40	5 11/16	0.258	5.047
		80		0.375	4.813
		120		0.500	4.563
		160		0.625	4.313
6	6.625	40	6 25/32	0.280	6.065
		80		0.432	5.761
		120		0.562	5.501
		160		0.719	5.187
8	8.625	40	8 25/32	0.322	7.981
		60		0.406	7.813
		80		0.500	7.625
		100		0.594	7.437
10	10.750	120	10 15/16	0.719	7.187
		140		0.812	7.001
		160		0.875	6.875
		XXS		0.906	6.813
12	12.750	40	12 31/32	0.365	10.020
		60		0.500	9.750
		80		0.594	9.562
		100		0.719	9.312
14	14.000	120	14 1/4	0.844	9.062
		140		1.000	8.750
		160		1.125	8.500
		XXS		1.312	8.126
16	16.000	40	16 1/4	0.375	12.000
		60		0.406	11.938
		80		0.500	11.750
		100		0.562	11.625
18	18.000	120	18 9/32	0.688	11.375
		140		1.00	10.750
		160		1.125	10.500
		XXS		1.312	10.126
20	20.000	40	20 5/16	0.375	13.250
		60		0.438	13.125
		80		0.500	13.000
		100		0.594	12.812
24	24.000	120	24 3/8	0.750	12.500
		140		0.938	12.124
		160		1.094	11.812
		XXS		1.250	11.500
24	24.000	30	24 3/8	0.375	15.250
		40		0.500	15.000
		60		0.656	14.688
		80		0.844	14.312
24	24.000	100	24 3/8	1.031	13.938
		120		1.219	13.562
		140		1.438	13.124
		160		1.594	12.812
24	24.000	40	24 3/8	0.562	16.876
		60		0.750	16.500
		80		0.938	16.124
		100		1.156	15.688
24	24.000	120	24 3/8	1.375	15.250
		140		1.562	14.876
		160		1.781	14.438
		XXS		1.969	14.062
24	24.000	30	24 3/8	0.562	18.812
		40		0.688	18.376
		60		0.969	17.938
		80		1.219	17.438
24	24.000	100	24 3/8	1.500	17.000
		120		1.750	16.500
		140		2.062	16.062
		160		2.344	15.624



BONNEY FORGE

# ENGINEERING SPECIFICATIONS

## FLANGE DIMENSIONS ASME B 16.5 and MSS-SP-44

	Nominal Pipe Size	Flange Diameter A	Flange Thickness		Diameter of Raised Face C	Diameter of Bolt Circle D	Diameter of Bolt Holes E	Number of Bolts	Diameter of Bolts
			Companion Flange B	Valve Flange B					
<b>ASME 150</b>	1/2	3 1/2	7/16	-	1 3/8	2 3/8	5/8	4	1/2
	3/4	3 1/2	1/2	-	1 11/16	2 3/4	5/8	4	1/2
	1	4 1/2	9/16	7/16	2	3 1/8	5/8	4	1/2
	1 1/4	4 1/2	5/8	1/2	2 1/2	3 1/2	5/8	4	1/2
	1 1/2	5	11/16	9/16	2 7/8	3 7/8	5/8	4	1/2
	2	6	3/4	5/8	3 5/8	4 3/4	3/4	4	5/8
	2 1/2	7	7/8	11/16	4 1/8	5 1/2	3/4	4	5/8
	3	7 1/2	15/16	3/4	5	6	3/4	4	5/8
	3 1/2	8 1/2	15/16	13/16	5 1/2	7	3/4	8	5/8
	4	9	15/16		6 3/16	7 1/2	3/4	8	5/8
	5	10	15/16		7 5/16	8 1/2	7/8	8	3/4
	6	11	1		8 1/2	9 1/2	7/8	8	3/4
	8	13 1/2	1 1/8		10 5/8	11 3/4	7/8	8	3/4
	10	16	1 3/16		12 3/4	14 1/4	1	12	7/8
	12	19	1 1/4		15	17	1	12	7/8
	14	21	1 3/8		16 1/4	18 3/4	1 1/8	12	1
	16	23 1/2	1 7/16		18 1/2	21 1/4	1 1/8	16	1
	16	25	1 9/16		21	22 3/4	1 1/4	16	1 1/8
	20	27 1/2	1 11/16		23	25	1 1/4	20	1 1/8
	24	32	1 7/8		27 1/4	29 1/2	1 3/8	20	1 1/8
	26	34 1/4	1 3/8		29 1/2	31 3/4	1 5/8	24	1 1/4
	28	36 1/2	1 7/16		31 1/2	34	1 5/8	28	1 1/4
	30	38 3/4	1 9/16		33 3/4	36	1 5/8	28	1 1/4
	32	41 3/4	1 11/16		36	38 1/2	1 5/8	28	1 1/2
34	43 3/4	1 7/8		38	40 1/2	1 5/8	32	1 1/2	
36	46	3 9/16		40 1/4	42 3/4	1 5/8	32	1 1/2	
38	48 3/4	3 7/16		42 1/4	45 1/4	1 5/8	32	1 1/2	
40	50 3/4	3 9/16		44 1/4	47 1/4	1 5/8	36	1 1/2	
42	53	3 13/16		47	49 1/2	1 5/8	36	1 1/2	
<b>ASME 300</b>	1/2	3 3/4	9/16		1 3/8	2 5/8	5/8	4	1/2
	3/4	4 5/8	5/8		1 11/16	3 1/4	3/4	4	5/8
	1	4 7/8	11/16		2	3 1/2	3/4	4	5/8
	1 1/4	5 1/4	3/4		2 1/2	3 7/8	3/4	4	5/8
	1 1/2	6 1/8	13/16		2 7/8	4 1/2	7/8	4	3/4
	2	6 1/2	7/8		3 5/8	5	3/4	8	5/8
	2 1/2	7 1/2	1		4 1/8	5 7/8	7/8	8	3/4
	3	8 1/4	1 1/8		5	6 5/8	7/8	8	3/4
	3 1/2	9	1 13/16		5 1/2	7 1/4	7/8	8	3/4
	4	10	1 1/4		6 3/16	7 7/8	7/8	8	3/4
	5	11	1 3/8		7 5/16	9 1/4	7/8	8	3/4
	6	12 1/2	1 7/16		8 1/2	10 5/8	7/8	12	3/4
	8	15	1 5/8		10 5/8	13	1	12	7/8
	10	17 1/2	1 7/8		12 3/4	15 1/4	1 1/8	16	1
	12	20 1/2	2		15	17 3/4	1 1/4	16	1 1/8
	14	23	2 1/8		16 1/4	20 1/4	1 1/4	20	1 1/8
	16	25 1/2	2 1/4		18 1/2	22 1/2	1 3/8	20	1 1/4
	16	28	2 3/8		21	24 3/4	1 3/8	24	1 1/4
	20	30 1/2	2 1/2		23	27	1 3/8	24	1 1/4
	24	36	2 3/4		27 1/4	32	1 5/8	24	1 1/2
	26	38 1/4	3 1/8		29 1/2	34 1/2	1 3/4	28	1 5/8
	28	40 3/4	3 3/8		31 1/2	37	1 3/4	28	1 5/8
	30	43	3 5/8		33 3/4	39 1/4	1 7/8	28	1 3/4
	32	45 1/4	3 7/8		36	41 1/2	2	28	1 7/8
34	47 1/2	4		38	43 1/2	2	28	1 7/8	
36	50	4 1/8		40 1/4	46	2 1/8	32	2	
38	46	4 1/4		40 1/2	43	1 5/8	32	1 1/2	
40	48 3/4	4 1/2		42 3/4	45 1/2	1 3/4	32	1 5/8	

The regular 1/16-inch raised face of 150 lb. flanges is included in the minimum flange thickness given, but other raised faces must be added thereto. The bolt holes, which are in multiples of four, are drilled to straddle the centerline unless otherwise ordered.

The regular 1/16-inch raised face of 300 lb. flanges is included in the minimum flange thickness given, but other raised faces must be added thereto. The bolt holes, which are in multiples of four, are drilled to straddle the centerline unless otherwise ordered.

End Flange dimensions comply with ASME B 16.5 and MSS-SP-44  
All dimensions are in inches

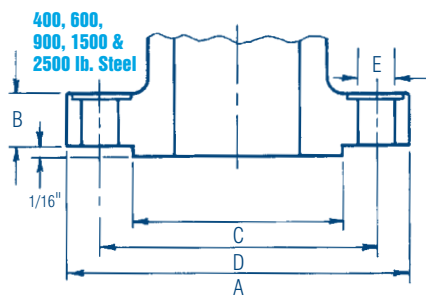
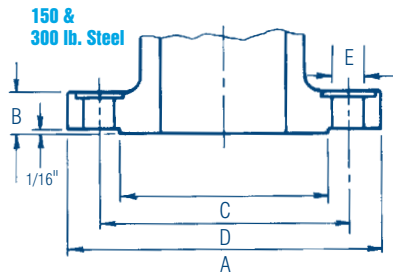

	Nominal Pipe Size	Flange Diameter A	Flange Thickness	Diameter of Raised Face C	Diameter of Bolt Circle D	Diameter of Bolt Holes E	Number of Bolts	Diameter of Bolts
<b>ASME 600</b>	1/2	3 3/4	9/16	1 3/8	2 5/8	5/8	4	1/2
	3/4	4 5/8	5/8	1 11/16	3 1/4	3/4	4	5/8
	1	4 7/8	11/16	2	3 1/2	3/4	4	5/8
	1 1/4	5 1/4	13/16	2 1/2	3 7/8	3/4	4	5/8
	1 1/2	6 1/8	7/8	2 7/8	4 1/2	7/8	4	5/8
	2	6 1/2	1	3 5/8	5	3/4	8	5/8
	2 1/2	7 1/2	1 1/8	4 1/8	5 7/8	7/8	8	3/4
	3	8 1/4	1 1/4	5	6 5/8	7/8	8	3/4
	3 1/2	9	1 3/8	5 1/2	7 1/4	1	8	7/8
	4	10 3/4	1 1/2	6 3/16	8 1/2	1	8	7/8
	5	13	1 3/4	7 5/16	10 1/2	1 1/8	8	1
	6	14	1 7/8	8 1/2	11 1/2	1 1/8	12	1
	8	16 1/2	2 3/16	10 5/8	13 3/4	1 1/4	12	1 1/8
	10	20	2 1/2	12 3/4	17	1 3/8	16	1 1/4
	12	22	2 5/8	15	19 1/4	1 3/8	20	1 1/4
	14	23 3/4	2 3/4	16 1/4	20 3/4	1 1/2	20	1 3/8
	16	27	3	18 1/2	23 3/4	1 5/8	20	1 1/2
	18	29 1/4	3 1/4	21	25 3/4	1 3/4	20	1 5/8
	20	32	3 1/2	23	28 1/2	1 3/4	24	1 5/8
	24	37	4	27 1/4	33	2	24	1 7/8
	26	40	4 1/4	29 1/2	36	2	28	1 7/8
	28	42 1/4	4 3/8	31 1/2	38	2 1/8	28	2
	30	44 1/2	4 1/2	33 3/4	40 1/2	2 1/8	28	2
	32	47	4 5/8	36	42 1/2	2 3/8	28	2 1/4
34	49	4 3/4	38	44 1/2	2 3/8	28	2 1/4	
36	51 3/4	4 7/8	40 1/4	47	2 5/8	28	2 1/2	
<b>ASME 900</b>	3	9 1/2	1 1/2	5	7 1/2	1	8	7/8
	4	11 1/2	1 3/4	6 3/16	9 1/4	1 1/4	8	1 1/8
	5	13 3/4	2	7 5/16	11	1 3/8	8	1 1/4
	6	15	2 3/16	8 1/2	12 1/2	1 1/4	12	1 1/8
	8	18 1/2	2 1/2	10 5/8	15 1/2	1 1/2	12	1 3/8
	10	21 1/2	2 3/4	12 3/4	18 1/2	1 1/2	16	1 3/8
	12	24	3 1/8	15	21	1 1/2	20	1 3/8
	14	25 1/4	3 3/8	16 1/4	22	1 5/8	20	1 1/2
	16	27 3/4	3 1/2	18 1/2	24 1/4	1 3/4	20	1 5/8
	18	31	4	21	27	2	20	1 7/8
	20	33 3/4	4 1/4	23	29 1/2	2 1/8	20	2
	24	41	5 1/2	27 1/4	35 1/2	2 5/8	20	2 1/2

The regular 1/4-inch raised face of 600 lb. flanges is not included in the minimum flange thickness given. The bolt holes, which are in multiples of four, are drilled to straddle the center-line unless otherwise ordered.

Use 1500 lb. dimensions in sizes smaller than 3-inch.

End Flange dimensions comply with ASME B 16.5 and MSS-SP-44  
All dimensions are in inches



BONNEY FORGE

# ENGINEERING SPECIFICATIONS

## RING JOINT FACINGS

ASME B 16.5 and B 16.20

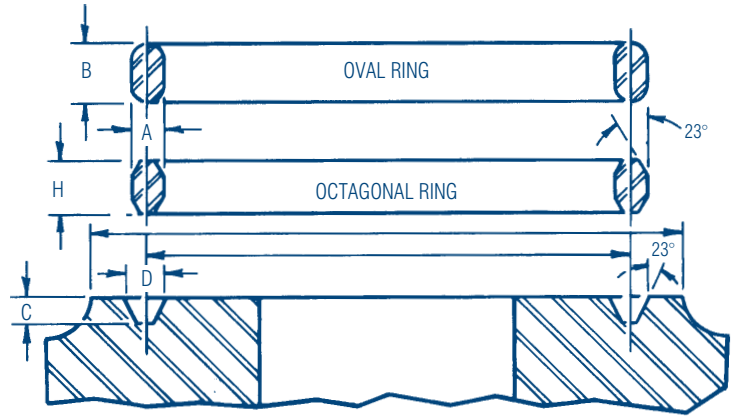

Groove suitable for either Oval or Octagonal ring

	Nominal Pipe Size	Ring Number	Ring Width A	Oval Ring Height B	Groove Width D	Octagonal Ring Height H	Ring Joint Raised Face Diameter K	Groove Depth L	Ring & Groove Pitch Diameter P
<b>150 LB.</b>	1	R15	5/16	9/16	11/32	1/2	2 1/2	1/4	1 7/8
	1 1/4	R17	5/16	9/16	11/32	1/2	2 7/8	1/4	2 1/4
	1 1/2	R19	5/16	9/16	11/32	1/2	3 1/4	1/4	2 9/16
	2	R22	5/16	9/16	11/32	1/2	4	1/4	3 1/4
	2 1/2	R25	5/16	9/16	11/32	1/2	4 3/4	1/4	4
	3	R29	5/16	9/16	11/32	1/2	5 1/4	1/4	4 1/2
	4	R36	5/16	9/16	11/32	1/2	6 3/4	1/4	5 7/8
	5	R40	5/16	9/16	11/32	1/2	7 5/8	1/4	6 3/4
	6	R43	5/16	9/16	11/32	1/2	8 5/8	1/4	7 5/8
	8	R48	5/16	9/16	11/32	1/2	10 3/4	1/4	9 3/4
	10	R52	5/16	9/16	11/32	1/2	13	1/4	12
	12	R56	5/16	9/16	11/32	1/2	16	1/4	15
	14	R59	5/16	9/16	11/32	1/2	16 3/4	1/4	15 5/8
	16	R64	5/16	9/16	11/32	1/2	19	1/4	17 7/8
	18	R68	5/16	9/16	11/32	1/2	21 1/2	1/4	20 3/8
	20	R72	5/16	9/16	11/32	1/2	23 1/2	1/4	22
24	R76	5/16	9/16	11/32	1/2	28	1/4	26 1/2	
<b>300, 600 LB.</b>	1/2	R11	1/4	7/16	9/32	3/8	2	7/32	1 11/32
	3/4	R13	5/16	9/16	11/32	1/2	2 1/2	1/4	1 11/16
	1	R16	5/16	9/16	11/32	1/2	2 3/4	1/4	2
	1 1/4	R18	5/16	9/16	11/32	1/2	3 1/8	1/4	2 3/8
	1 1/2	R20	5/16	9/16	11/32	1/2	3 9/16	1/4	2 11/16
	2	R23	7/16	11/16	15/32	5/8	4 1/4	5/16	3 1/4
	2 1/2	R26	7/16	11/16	15/32	5/8	5	5/16	4
	3	R31	7/16	11/16	15/32	5/8	5 3/4	5/16	4 7/8
	4	R37	7/16	11/16	15/32	5/8	6 7/8	5/16	5 7/8
	5	R41	7/16	11/16	15/32	5/8	8 1/4	5/16	7 1/8
	6	R45	7/16	11/16	15/32	5/8	9 1/2	5/16	8 5/16
	8	R49	7/16	11/16	15/32	5/8	11 7/8	5/16	10 5/8
	10	R53	7/16	11/16	15/32	5/8	14	5/16	12 3/4
	12	R57	7/16	11/16	15/32	5/8	16 1/4	5/16	15
	14	R61	7/16	11/16	15/32	5/8	18	5/16	16 1/2
	16	R65	7/16	11/16	15/32	5/8	20	5/16	18 1/2
	18	R69	7/16	11/16	15/32	5/8	22 5/8	5/16	21
	20	R73	1/2	3/4	17/32	11/16	25	3/8	23
24	R77	5/8	7/8	21/32	13/16	29 1/2	7/16	27 1/4	

All dimensions are in inches



	Nominal Pipe Size	Ring Number	Ring Width A	Oval Ring Height B	Groove Width D	Octagonal Ring Height H	Ring Joint Raised Face Diameter K	Groove Depth L	Ring & Groove Pitch Diameter P
<b>900 LB.</b>	3	R31	7/16	11/16	15/32	5/8	6 1/8	5/16	4 7/8
	4	R37	7/16	11/16	15/32	5/8	7 1/8	5/16	5 7/8
	5	R41	7/16	11/16	15/32	5/8	8 1/2	5/16	7 1/8
	6	R45	7/16	11/16	15/32	5/8	9 1/2	5/16	8 5/16
	8	R49	7/16	11/16	15/32	5/8	12 1/8	5/16	10 5/8
	10	R53	7/16	11/16	15/32	5/8	14 1/4	5/16	12 3/4
	12	R57	7/16	11/16	15/32	5/8	16 1/2	5/16	15
	14	R62	5/8	7/8	21/32	13/16	18 3/8	7/16	16 1/2
	16	R66	5/8	7/8	21/32	13/16	20 5/8	7/16	18 1/2
	18	R70	3/4	1	25/32	15/16	23 3/8	1/2	21
	20	R74	3/4	1	25/32	15/16	25 1/2	1/2	23
	24	R78	1	1 5/16	1 1/16	1 1/4	30 3/8	5/8	27 1/4
<b>1500 LB.</b>	1/2	R12	5/16	9/16	11/32	1/2	2 3/8	1/4	1 9/16
	1/4	R14	5/16	9/16	11/32	1/2	2 3/8	1/4	1 3/4
	1	R16	5/16	9/16	11/32	1/2	2 13/16	1/4	2
	1 1/4	R18	5/16	9/16	11/32	1/2	3 3/16	1/4	2 3/8
	1 1/2	R20	5/16	9/16	11/32	1/2	3 5/8	1/4	2 11/16
	2	R24	7/16	11/16	15/32	5/8	4 7/8	5/16	3 3/4
	2 1/2	R27	7/16	11/16	15/32	5/8	5 3/8	5/16	4 1/4
	3	R35	7/16	11/16	15/32	5/8	6 5/8	5/16	5 3/8
	4	R39	7/16	11/16	15/32	5/8	7 5/8	5/16	6 3/8
	5	R44	7/16	11/16	15/32	5/8	9	5/16	7 1/8
	6	R46	1/2	3/4	17/32	11/16	9 3/4	3/8	8 5/16
	8	R50	5/8	7/8	21/32	13/16	12 1/2	7/16	10 5/8
	10	R54	5/8	7/8	21/32	13/16	14 5/8	7/16	12 3/4
	12	R58	7/8	1 1/8	29/32	1 1/16	17 1/4	9/16	15
	14	R63	1	1 5/16	1 1/16	1 1/4	19 1/4	5/8	16 1/2
	16	R67	1 1/8	1 7/16	1 3/16	1 3/8	21 1/2	11/16	18 1/2
	18	R71	1 1/8	1 7/16	1 3/16	1 3/8	24 1/8	11/16	21
	20	R75	1 1/4	1 9/16	1 5/16	1 1/2	26 1/2	11/16	23
	24	R79	1 3/8	1 3/4	1 7/16	1 5/8	31 1/4	13/16	27 1/4

All dimensions are in inches



BONNEY FORGE

# ENGINEERING SPECIFICATIONS

## STANDARD CLASS PRESSURE TEMPERATURE RATINGS

ASME B 16.34

Working Class by Pressures	Temperature, °F	A 216 WCB(a)	A 352 LCB(d)	A 216 WCC(a) A 352 LC2(d) A 352 LC3(d) A 352 LCC(e)	A 217 WC1(b) A 352 LC1(d)	A 217 WC4(h) A 217 WC5(i)	A 217 WC6(j)	A 217 WC9(i)	A 217 C5	A 217 C12	A 351 CF3(f) A 351 CF8	A 351 CF3M(g) A 351 CF8M	A 351 CF8C	A 351 CN7M(l)
		Working Pressures in PSI												
150 LB.	-20 to 100	285	265	290	265	290	290	290	290	290	275	275	275	230
	200	260	255	260	255	260	260	260	260	260	230	235	255	200
	300	230	230	230	230	230	230	230	230	230	205	215	230	180
	400	200	200	200	200	200	200	200	200	200	190	195	200	160
	500	170	170	170	170	170	170	170	170	170	170	170	170	150
	600	140	140	140	140	140	140	140	140	140	140	140	140	140
	650	125	125	125	125	125	125	125	125	125	125	125	125	125
	700	110	110	110	110	110	110	110	110	110	110	110	110	110
	750	95	95	95	95	95	95	95	95	95	95	95	95	95
	800	80	80	80	80	80	80	80	80	80	80	80	80	80
	850	65	65	65	65	65	65	65	65	65	65	65	65	-
	900	50	50	50	50	50	50	50	50	50	50	50	50	-
	950	35	35	35	35	35	35	35	35	35	35	35	35	-
	1000	20	20	20	20	20	20	20	20	20	20	20	20	-
	1050	-	-	-	-	20(1)	20(1)	20(1)	20(1)	20(1)	20(1)	20(1)	20(1)	20(1)
	1100	-	-	-	-	-	-	20(1)	20(1)	20(1)	20(1)	20(1)	20(1)	20(1)
	1150	-	-	-	-	-	-	20(1)	20(1)	20(1)	20(1)	20(1)	20(1)	20(1)
	1200	-	-	-	-	-	-	15(1)	15(1)	15(1)	20(1)	20(1)	20(1)	20(1)
	1250	-	-	-	-	-	-	-	-	-	20(1)	20(1)	20(1)	20(1)
	1300	-	-	-	-	-	-	-	-	-	20(1)	20(1)	20(1)	20(1)
1350	-	-	-	-	-	-	-	-	-	20(1)	20(1)	20(1)	-	
1400	-	-	-	-	-	-	-	-	-	20(1)	20(1)	15(1)	-	
1450	-	-	-	-	-	-	-	-	-	20(1)	20(1)	10(1)	-	
1500	-	-	-	-	-	-	-	-	-	15(1)	15(1)	10(1)	-	
300 LB.	-20 to 100	740	695	750	695	750	750	750	750	750	720	720	720	600
	200	680	660	750	660	750	750	750	750	750	600	620	660	520
	300	655	640	730	640	730	720	730	730	730	540	560	615	465
	400	635	615	705	615	705	695	705	705	705	495	515	575	420
	500	605	585	665	585	665	665	665	665	665	465	480	540	390
	600	570	550	605	550	605	605	605	605	605	440	450	515	360
	650	550	535	590	535	590	590	590	590	590	430	440	505	450
	700	530	510	555	510	570	570	570	570	570	420	435	495	445
	750	505	475	505	475	530	530	530	530	530	415	425	490	440
	800	410	390	410	390	510	510	510	510	510	405	420	485	430
	850	320	300	320	300	485	485	485	485	485	395	420	485	-
	900	230	200	225	200	450	450	450	450	375	390	415	450	-
	950	135	135	135	135	315	315	320	385	275	380	385	385	-
	1000	85	85	85	85	200	215	265	200	255	355	365	365	-
	1050	-	-	-	-	160	145	175	145	170	325	360	360	-
	1100	-	-	-	-	-	-	95	110	100	255	305	310	-
	1150	-	-	-	-	-	-	65	70	60	205	235	210	-
	1200	-	-	-	-	-	-	40	40	35	165	185	150	-
	1250	-	-	-	-	-	-	-	-	-	135	145	115	-
	1300	-	-	-	-	-	-	-	-	-	115	115	75	-
1350	-	-	-	-	-	-	-	-	-	95	95	50	-	
1400	-	-	-	-	-	-	-	-	-	75	75	40	-	
1450	-	-	-	-	-	-	-	-	-	60	60	30	-	
1500	-	-	-	-	-	-	-	-	-	40	40	25	-	

Working Class by Pressures	Temperature, °F	A 216 WCB(a)	A 352 LCB(d)	A 216 WCC(a) A 352 LC2(d) A 352 LC3(d) A 352 LCC(e)	A 217 WC1(b) A 352 LC1(d)	A 217 WC4(h) A 217 WC5(i)	A 217 WC6(j)	A 217 WC9(j)	A 217 C5	A 217 C12	A 351 CF3(f) A 351 CF8	A 351 CF3M(g) A 351 CF8M	A 351 CF8C	A 351 CN7M(l)	
		Working Pressures in PSI													
600 LB.	-20 to 100	1480	1395	1500	1395	1500	1500	1500	1500	1500	1440	1440	1440	1200	
	200	1360	1320	1500	1320	1500	1500	1500	1500	1500	1200	1240	1325	1035	
	300	1310	1275	1455	1275	1455	1445	1455	1455	1455	1075	1120	1235	930	
	400	1265	1230	1405	1230	1410	1385	1410	1410	1410	995	1025	1150	845	
	500	1205	1175	1330	1175	1330	1330	1330	1330	1330	930	955	1085	780	
	600	1135	1105	1210	1105	1210	1210	1210	1210	1210	885	900	1030	720	
	650	1100	1065	1175	1065	1175	1175	1175	1175	1175	865	885	1015	900	
	700	1060	1025	1110	1025	1135	1135	1135	1135	1135	845	870	995	890	
	750	1015	955	1015	955	1065	1065	1065	1065	1065	825	855	985	880	
	800	825	780	825	780	1015	1015	1015	1015	1015	810	845	975	865	
	850	640	595	640	595	975	975	975	975	975	790	835	970	-	
	900	460	405	445	405	900	900	900	745	900	780	830	900	-	
	950	275	275	275	275	630	640	755	550	755	765	775	775	-	
	1000	170	170	170	170	405	430	535	400	505	710	725	725	-	
	1050	-	-	-	-	315	290	350	290	345	650	720	720	-	
	1100	-	-	-	-	-	-	190	220	200	225	515	610	625	-
	1150	-	-	-	-	-	-	130	135	125	150	410	475	420	-
	1200	-	-	-	-	-	-	80	80	70	105	330	370	300	-
1250	-	-	-	-	-	-	-	-	-	-	265	295	225	-	
1300	-	-	-	-	-	-	-	-	-	-	225	235	150	-	
1350	-	-	-	-	-	-	-	-	-	-	185	190	105	-	
1400	-	-	-	-	-	-	-	-	-	-	150	150	80	-	
1450	-	-	-	-	-	-	-	-	-	-	115	115	60	-	
1500	-	-	-	-	-	-	-	-	-	-	85	85	55	-	
900 LB.	-20 to 100	2220	2090	2250	2090	2250	2250	2250	2250	2250	2160	2160	2160	1800	
	200	2035	1980	2250	1980	2250	2250	2250	2250	2250	1800	1860	1985	1555	
	300	1965	1915	2185	1915	2185	2165	2185	2185	2185	1615	1680	1850	1395	
	400	1900	1845	2110	1845	2115	2080	2115	2115	2115	1490	1540	1730	1265	
	500	1810	1760	1995	1760	1995	1995	1995	1995	1995	1395	1435	1625	1165	
	600	1705	1655	1815	1655	1815	1815	1815	1815	1815	1325	1355	1550	1080	
	650	1650	1600	1765	1600	1765	1765	1765	1765	1765	1295	1325	1520	1350	
	700	1590	1535	1665	1535	1705	1705	1705	1705	1705	1265	1305	1490	1335	
	750	1520	1430	1520	1430	1595	1595	1595	1595	1595	1240	1280	1475	1320	
	800	1235	1175	1235	1175	1525	1525	1525	1525	1525	1215	1265	1460	1295	
	850	955	895	955	895	1460	1460	1460	1460	1460	1190	1255	1455	-	
	900	690	605	670	605	1350	1350	1350	1120	1350	1165	1245	1350	-	
	950	410	410	410	410	945	995	1160	825	1130	1145	1160	1160	-	
	1000	255	255	255	255	605	650	800	595	760	1065	1090	1090	-	
	1050	-	-	-	-	475	430	525	430	515	975	1080	1080	-	
	1100	-	-	-	-	-	-	290	330	300	340	770	915	935	-
	1150	-	-	-	-	-	-	195	205	185	225	615	710	625	-
	1200	-	-	-	-	-	-	125	125	105	155	495	555	455	-
1250	-	-	-	-	-	-	-	-	-	-	400	440	340	-	
1300	-	-	-	-	-	-	-	-	-	-	340	350	225	-	
1350	-	-	-	-	-	-	-	-	-	-	280	290	155	-	
1400	-	-	-	-	-	-	-	-	-	-	225	225	125	-	
1450	-	-	-	-	-	-	-	-	-	-	175	175	95	-	
1500	-	-	-	-	-	-	-	-	-	-	125	125	80	-	



BONNEY FORGE

# ENGINEERING SPECIFICATIONS

## STANDARD CLASS PRESSURE TEMPERATURE RATINGS

ASME B 16.34

Working Class by Pressures	Temperature, °F	A 216 WCB(a)	A 352 LCB(d)	A 216 WCC(a) A 352 LC2(d) A 352 LC3(d) A 352 LCC(e)	A 217 WC1(b) A 352 LC1(d)	A 217 WC4(h) A 217 WC5(i)	A 217 WC6(j)	A 217 WC9(i)	A 217 C5	A 217 C12	A 351 CF3(f) A 351 CF8	A 351 CF3M(g) A 351 CF8M	A 351 CF8C	A 351 CN7M(l)
		Working Pressures in PSI												
<b>1500 LB.</b>	-20 to 100	3705	3480	3750	3480	3750	3750	3750	3750	3750	3600	3600	3600	3000
	200	3395	3300	3750	3300	3750	3750	3750	3750	3750	3000	3095	3310	2590
	300	3270	3190	3640	3190	3640	3610	3640	3640	3640	2690	2795	3085	2330
	400	3170	3075	3520	3075	3530	3465	3530	3530	3530	2485	2570	2880	2110
	500	3015	2930	3325	2930	3325	3325	3325	3325	3325	2330	2390	2710	1945
	600	2840	2755	3025	2755	3025	3025	3025	3025	3025	2210	2255	2580	1800
	650	2745	2665	2940	2665	2940	2940	2940	2940	2940	2160	2210	2530	2250
	700	2665	2560	2775	2560	2840	2840	2840	2840	2840	2110	2170	2485	2225
	750	2535	2385	2535	2385	2660	2660	2660	2660	2660	2065	2135	2460	2200
	800	2055	1955	2055	1955	2540	2540	2540	2540	2540	2030	2110	2435	2160
	850	1595	1490	1595	1490	2435	2435	2435	2435	2435	1980	2090	2425	-
	900	1150	1010	1115	1010	2245	2245	2245	1870	2245	1945	2075	2245	-
	950	685	685	685	685	1575	1595	1930	1370	1885	1910	1930	1930	-
	1000	430	430	430	430	1010	1080	1335	995	1270	1770	1820	1820	-
	1050	-	-	-	-	790	720	875	720	855	1630	1800	1800	-
	1100	-	-	-	-	-	-	480	550	495	565	1285	1525	1560
	1150	-	-	-	-	-	-	325	345	310	375	1030	1185	1045
	1200	-	-	-	-	-	-	205	205	170	255	825	925	755
	1250	-	-	-	-	-	-	-	-	-	-	670	735	565
	1300	-	-	-	-	-	-	-	-	-	-	565	585	375
1350	-	-	-	-	-	-	-	-	-	-	465	480	255	
1400	-	-	-	-	-	-	-	-	-	-	380	380	205	
1450	-	-	-	-	-	-	-	-	-	-	290	290	155	
1500	-	-	-	-	-	-	-	-	-	-	205	205	135	

NOTE:

(1) For welding end valves only. Flanged end ratings terminate at 1000°F.

NOTES:

- (a) Permissible, but not recommended for prolonged usage above about 800°F.
- (b) Permissible, but not recommended for prolonged usage above about 850°F.
- (d) Not to be used over 650°F.
- (e) Not to be used over 700°F.
- (f) Not to be used over 800°F.
- (g) Not to be used over 850°F.
- (h) Not to be used over 1000°F.
- (i) Not to be used over 1050°F.
- (j) Not to be used over 1100°F.
- (l) Ratings apply for 300°F and lower.





BONNEY FORGE

## GATE VALVE “O.S.” & “Y”

### 1.0 Periodic Inspections

**1.1** The valve stem packing should be inspected at least monthly. If the stem packing shows signs of leakage, simply tighten the adjusting nuts to compress the packing. Do not over-tighten the adjusting nuts as this will make operation of the valve more difficult. If, after tightening the adjusting nuts to their fullest extent, the leakage does not stop, it is then necessary to replace the stem packing. It is not recommended that additional packing rings be added to the stuffing box as this may cause damage to the stem sealing system. Please contact Bonney Forge or its distributor for new stem packing sets. For packing replacement see paragraphs 2.2 and 2.3.

**1.2** The lubrication of the yoke nut should be inspected at least monthly. A high pressure grease gun should be used for valves supplied with ball type grease fittings. For valves supplied with a Stauffer type grease cup, the cup should be checked to assure that it is full so that the grease can be injected by turning the screw cap. The valve stem threads should also be given a coating of lubricant.

**1.3** Bonnet bolt tension should be checked periodically when valves are used in high temperature applications where creep may occur. Although leaks through ring joints are rare, erosion or corrosion could cause rings to fail. In these cases, a new ring gasket is required.

### 2.0 Extraordinary Maintenance or Replacement of Damaged Parts

**2.1 Stem.** If the stem locks or "freezes", causes can generally be attributed to worn packing, a dry yoke nut or dry stem threads. In either of these cases, the following service is required:

- a\*) Unscrew gland nuts, remove the gland flange and bushing to expose stem packing and lantern ring. Replace stem packing if it is damaged.
- b) Check lubrication of yoke nut. If it is dry, remove the yoke nut and determine if there is evidence of seizure marks. If so, replace it with a new yoke nut. Also check the nut and stem threads.

### 2.2 Disassembly of Stem Packing.\*

- a) In those cases where the valve can not be removed from the piping system, it is important that prior to servicing, the valve be opened to its fullest extent. Partially unscrew nuts to reduce the compression load on the stuffing box. Remove the stem packing and then replace with new set(s) of packing. Finally, tighten nuts sufficiently while allowing the stem to operate smoothly.
- b) To replace the stem when the valve is completely disassembled for general maintenance follow this procedure:
  - Open the valve half way and remove bonnet bolts and nuts.
  - Lift up the bonnet to remove the wedge.
  - With the bonnet removed, unscrew the gland bolts and lift up the gland flange exposing the stem packing.
  - Remove the stem packing.
  - Remove the stem through the stuffing box.

\*CAUTION: Always be sure that the valve is de-pressurized and isolated prior to performing any maintenance work.



BONNEY FORGE

## GATE VALVE “O.S.” & “Y” (CONTINUED)

### 2.3 The procedure to re-assembly the valve is as follows:

Re-insert the stem through the stuffing box taking special care to reassemble parts in sequence. Insert the remaining packing rings into the stuffing box and compress using the gland and flange. Then, reassemble nuts and tighten. Note, the stem must slide freely through the stuffing box without applying excessive force. Finally, install the bonnet gasket making sure it is not damaged. The gasket should be replaced if there is any question as to its performance.

**2.4** Raise the bonnet, making sure the stem is in a half open position, then connect disc to stem. Lower bonnet on to the valve body making sure that the disc fits exactly into body guides and the bonnet gasket is properly seated. Align holes and tighten bonnet nuts taking care that excessive force is not used, possibly damaging the gasket. Hydrostatically test the valve to assure that there is no leakage.

### 2.5 Disassembly of yoke nut

When necessary use the following procedure for disassembling and replacing yoke nut:

- a) direct hand-operated valves (handwheel)
  - remove set screw;
  - unscrew handwheel nut;
  - remove handwheel;
  - unscrew yoke nut retaining nut, removing spot welds if necessary;

Reverse the procedure for re-assembly.

- b) bevel gear operated valves
  - to remove the bevel gear from the valve, unscrew nuts and turn the handwheel in the open direction indicated by the arrow until the drive nuts are disengaged from the stem.
  - to check the condition of the drive nut or bearing, unscrew the retainer ring and remove the drive nut and bearing. If damaged, a new drive nut or bearing is necessary.

### 2.6 Wedge and Seats

Leakage through seats and wedges is not always easy to spot when valves are in service. However, when leaks are identified, immediate action is necessary. Any delay can permanently damage seat or wedge seal surfaces.

To repair or replace wedges or seats, the valve must be removed from the line and the following procedure should be applied:

- make sure that the valve is not under pressure before unscrewing bonnet nuts;
- remove the bonnet, being careful not to damage the gasket;
- remove the bonnet when the wedge is in the half open position;
- lift up the bonnet until the wedge is disconnected from the guides;
- release the wedge from the stem.

If seat surfaces show signs of seizing, pitting, grooves or other defects not deeper than 0.8 mm (1/32") it is possible to repair seating surfaces to its original conditions by relapping the surface with line grain abrasive paste, creating a perfect tightness once again.

Defects having a depth exceeding 0.8 mm (1/32") cannot be repaired by lapping. In this case, parts must be replaced.

It is recommended that the face of the disc be blued to check for contact of seating surface after final lapping. For re-assembly of valves use the procedure outlined under para. 2.4.

# GLOBE VALVE “O.S.” & “Y”

## 1.0 Periodic Inspections

**1.1** The valve stem packing should be inspected at least monthly. If the stem packing shows signs of leakage, simply tighten the adjusting nuts to compress the packing. Do not over-tighten the adjusting nuts as this will make operation of the valve more difficult. If, after tightening the adjusting nuts to their fullest extent, the leakage does not stop, it is then necessary to replace the stem packing. It is not recommended that additional packing rings be added to the stuffing box as this may cause damage to the stem sealing system. Please contact Bonney Forge or it's distributor for new stem packing sets. For packing replacement see paragraphs 2.2 and 2.3.

**1.2** The lubrication of the yoke nut should be inspected at least monthly. A high pressure grease gun should be used for valves supplied with ball type grease fittings. For valves supplied with a Stauffer type grease cup, the cup should be checked to assure that it is full so that the grease can be injected by turning the screw cap. The valve stem threads should also be given a coating of lubricant.

**1.3** Bonnet bolt tension should be checked periodically when valves are used in high temperature applications where creep may occur. Although leaks through ring joints are rare, erosion or corrosion could cause rings to fail. In these cases, a new ring gasket is required.

## 2.0 Extraordinary Maintenance or Replacement of Damaged Parts

**2.1 Stem.** If the stem locks or freezes, causes can generally be attributed to worn packing, a dry yoke nut or dry stem threads. In either of these cases, the following service is required:

- a\*) Unscrew gland nuts, remove gland flange and bushing to expose stem packing and lantern ring.  
Replace stem packing if it is damaged.
- b) Check lubrication of yoke nut. If it is dry, remove the yoke nut and determine if there is evidence of seizure marks.  
If so, replace it with a new yoke nut. Also check the nut and stem threads.

### 2.2 Disassembly of Stem Packing.\*

- a) In those cases where the valve cannot be removed from the piping system, it is important that prior to servicing, the valve be opened to its fullest extent. Partially unscrew nuts to reduce the compression load on the stuffing box. Remove the stem packing and then replace with new set(s) of packing. Reassemble plug and gland flange. Finally, tighten nuts sufficiently while allowing the stem to operate smoothly.
- b) To replace the stem when the valve is completely disassembled for general maintenance follow this procedure:
  - Open the valve and remove the bonnet bolts and nuts.
  - With the bonnet removed, unscrew the gland bolts and lift up the gland flange exposing the stem packing.
  - Remove the stem packing.
  - Remove handwheel, then turn stem to release it from yoke nut and remove from stuffing box.
  - Check condition of back-seat bushing for seizure marks. If apparent, order replacement parts.

\*CAUTION: Always be sure that the valve is de-pressurized and isolated prior to performing any maintenance work.



BONNEY FORGE

## GLOBE VALVE “O.S.” & “Y” (CONTINUED)

### 2.3 The procedure to re-assembling the valve is as follows:

Re-insert the stem through the stuffing box, taking special care to reassemble parts in sequence. Insert the remaining packing rings into the stuffing box and compress using the gland ring and flange. Then, reassemble nuts and tighten. Note, the stem must slide freely through the stuffing box without applying excessive force. Finally, install the bonnet gasket making sure it is not damaged. The gasket should be replaced if there is any question as to its performance.

**2.4** Raise the bonnet assembly, making sure the stem is in the fully open position. Lower bonnet on to the valve body making sure that the disc fits exactly into body guides and the bonnet gasket is properly seated. Align holes and tighten bonnet nuts taking care that excessive force is not used, possibly damaging the gasket. Hydrostatically test the valve to assure that there is no leakage.

### 2.5 Disassembly of yoke nut

When necessary use the following procedure for disassembling and replacing yoke nut:

- a) direct hand-operated valves (handwheel)
  - remove set screw;
  - unscrew handwheel nut;
  - remove handwheel;
  - unscrew yoke nut retaining nut, removing spot welds if necessary;
  - Reverse the procedure for re-assembly.
  
- b) bevel gear operated valves
  - to remove the bevel gear from the valve, unscrew nuts and turn the handwheel in the open direction indicated by the arrow until the drive nuts are disengaged from the stem.
  - to check the condition of the drive nut or bearing, unscrew the retainer ring and remove the drive nut and bearing. If damaged, a new drive nut or bearing is necessary.

### 2.6 Disc and Seats

Leakage through disc and seats is not always easy to spot when valves are in service. However, when leaks are identified, immediate action is necessary. Any delay can permanently damage seat or wedge seal surfaces.

To repair or replace the disc or seats, the valve must be removed from line, then use the following procedure:

- make sure that the valve is not under pressure before unscrewing bonnet nuts;
- remove bonnet, being careful not to damage the gasket;
- remove bonnet when disc is in full open position;
- lift up bonnet

If seat surfaces show signs of seizing, pitting, grooves or other defects not deeper than 1.5 mm (1/16") it is possible to repair seating surfaces to its original conditions by relapping the surface with fine grain abrasive paste, creating a perfect tightness once again. Defects having a depth exceeding 1.5 mm (1/16") cannot be repaired by lapping. In this case, parts must be replaced.

It is recommended that the face of the disc be blued to check for contact of seating surface after final lapping. For re-assembly of valves use the procedure outlined under para. 2.4.



## SWING CHECK VALVES

No periodic maintenance is necessary. If gasket leaks are detected, correct using the following procedure.

- 1** - Disassemble all cover bolts and nuts.
- 2** - For check valves in sizes 16" and larger, lift up the cover by using a lever inserted into the drilled and tapped cover hole. For valves in sizes 14" and smaller, use one or two bolts and nuts inserted into cover holes and, using adequate force, move the cover upwards.
- 3** - Check that the hinge, nut, and pin are in good condition and firmly connected. Replace damaged parts as necessary.
- 4** - Lift and remove the disc-hinge assembly. Movement should be free and not hindered by any malfunction of the hinge pin. Where disc travel is not sufficiently smooth, remove plugs or blind flanges and then remove hinge pin. Check surface for seizure marks. If marks are deeper than 1.5 mm (1/16"); re-machine hinge pin and re-assemble. If defect depth is greater than 1.5 mm (1/16") a new hinge pin is necessary. When reassembling hinge pin, it is recommended that the disc be removed by loosening nut.
- 5** - When leakage is due to deterioration of seal surfaces caused by corrosion or foreign substances, it must be determined whether the disc or seat seal are the cause.

a) Deterioration of disc surfaces:

Disassemble disc by removing nut and washer. Repair surface by grinding and relapping using fine grain abrasive paste.

b) Deterioration of seat seal surfaces:

When seal surfaces are damaged and defects are confined to a small area but are not deeper than 0.8 mm (1/32"), the seal surface can be repaired. The recommended method is to use a cast iron strap with an outside diameter matching the valve's raceway. Then using a fine grain abrasive paste between the strap and raceway, it is rotated on the seat to restore original tightness. When defects are deeper than 0.8 mm (1/32") and found on the entire seal surface, a new seat is required. To replace the new seat, use preferably a pneumatic tool with a shape to match the dimensions of the valve seat. It is recommended that an anti seizing compound be used when installing the replacement seat to make threading it in to the body easier.

**CAUTION:** Always be sure that the valve is de-pressurized and isolated prior to performing any maintenance work.



BONNEY FORGE

# STORAGE, INSTALLATION AND MAINTENANCE PROCEDURES

- HANDWHEEL NUT
- HANDWHEEL
- YOKE SLEEVE RETAINING NUT
- YOKE SLEEVE
- YOKE SLEEVE BEARING
- NUT
- GLAND FLANGE
- GLAND
- NUT
- PACKING
- BACK SEAT BUSHING
- NUT
- EYE BOLT
- PIN
- BONNET
- STUD BOLT
- STEM
- WEDGE
- SEAT RING
- BONNET GASKET
- BODY
- NUT
- PLATE
- PLUG

## GATE VALVE COMPONENTS

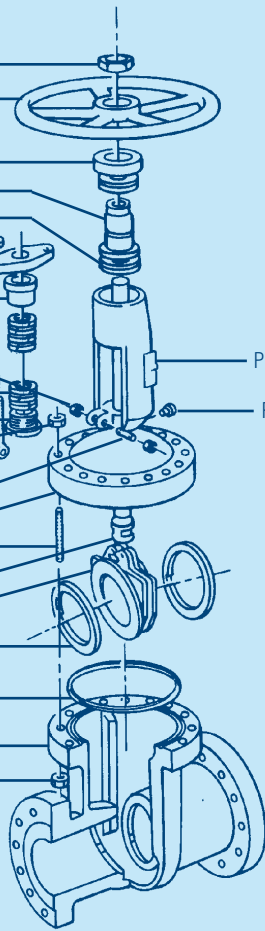

- HANDWHEEL NUT
- HANDWHEEL
- YOKE SLEEVE RETAINING NUT
- NUT
- GLAND FLANGE
- GLAND
- PACKING
- EYE BOLT
- BACK SEAT BUSHING
- PLUG
- PIN
- BONNET GASKET
- STEM
- DISC NUT
- HALF RING
- BONNET GASKET
- BODY
- SET SCREW
- PLATE
- NUT
- BONNET
- STUD BOLT
- NUT

## GLOBE VALVE COMPONENTS

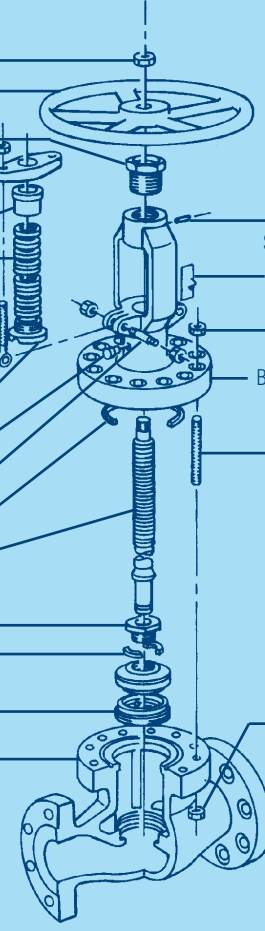

- PIN
- BONNET
- STUD BOLT
- GASKET
- PLUG
- PLUG GASKET
- NUT
- BODY
- PLUG
- PLUG GASKET
- HINGE PIN
- PIN
- NUT
- DISC WASHER
- HINGE DISC
- DISC
- SEAT RING

## SWING CHECK VALVE COMPONENTS

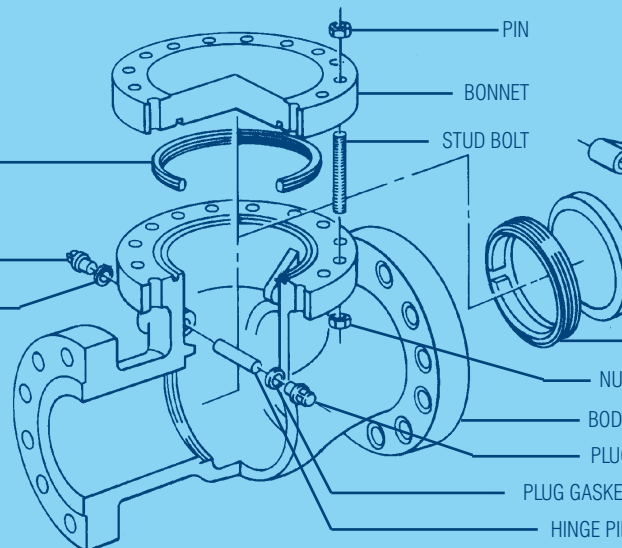







## GENERAL TERMS AND CONDITIONS OF SALE OF: BONNEY FORGE (HEREAFTER REFERRED TO AS “BF”)

<b>WARRANTY</b>	All products are warranted to be free from manufacturing defects for a period of one (1) year from date of shipment, and any found to be defective within that period will be replaced without charge, provided (1) that the product was used as recommended and in accordance with approved installation and operating practices. (2) that its failure resulted from a manufacturing defect and not from damage due to corrosive, abrasive, or other wear normally to be expected in the services involved. (3) that the product was not modified or changed (unless written approval was given by BF), and (4) that written notice of such defect is delivered to BF during such one (1) year period. BF will not be responsible for any labor, equipment, engineering or related costs or liability associated with the replacement of a defective product. The Uniform Commercial Code shall not apply to the sale, nor the Michigan statutes adopting the Uniform Commercial Code. This express warranty is in lieu of and excludes all other warranties, guarantees, or representations, expressed or implied. There are no implied warranties of merchantability or of fitness for a particular purpose.
<b>EXCLUSIONS</b>	Do not use BF products in aircraft or aerospace applications. No warranties, guarantees or representations of any kind are made with respect to such applications. The Purchaser assumes all risks of any use in such applications and will indemnify and hold harmless BF against and from any claims, costs (including attorneys fees) and liabilities arising out of such use.
<b>PURCHASER'S REMEDIES</b>	The Purchaser's remedies with respect to any product furnished by BF hereunder that is found not to be in conformity with the terms and conditions of the contract because of breach of contract, breach of express or implied warranty, or negligence shall be limited exclusively to the right of replacement of such defective product or, at our option, repayment of our sale price of the product. In no event shall BF be liable for claims (based upon breach of contract, breach of express or implied warranty, or negligence) for any other damages, whether direct, immediate, foreseeable, consequential, or special or for any expenses incurred by reason of the use or misuse, sale or fabrication of products which do or do not conform to the terms and conditions of the contract.
<b>PRICES</b>	Prices, and other terms of sale and payment, are subject to change without notice. Unless a contrary provision appears in this price schedule, quotation or order acknowledgment, prices may be withdrawn without notice at any time. Stenographic or clerical errors are subject to correction.
<b>ACCEPTANCE OF ORDERS</b>	All orders are subject to BF credit department approval prior to acceptance by BF. No assignment of the Purchaser's rights may be made without the written consent of BF.
<b>REMITTANCES</b>	All accounts are payable in United States funds, free of exchange, collection or any other charges. If in the sole discretion of BF the financial condition of the Purchaser at any time so requires, BF retains the right to require full or partial payment in advance.
<b>PARTIAL SHIPMENTS AND PAYMENTS</b>	BF reserves the right to make partial shipments from time to time and to render invoices therefore which shall be due and payable as provided in said invoices and the paragraph entitled. "Remittances" if the Purchaser becomes overdue in any such partial payment, BF shall be entitled to suspend work and or avail itself of other legal remedies.
<b>TAXES</b>	Unless otherwise specifically noted, the amount of any sale, use, occupancy, excise tax or other tax, of any nature, federal, state, or local for which BF is legally liable, either initially or through failure of payment by Purchaser, shall be added or be in addition to the price quoted and Purchaser agrees to pay the same to BF.
<b>SHORTAGES &amp; DAMAGES IN TRANSIT</b>	Claims for shortages must be made in writing within ten days after receipt of shipment, but loss of or damage to material in transit is the responsibility of the carrier.
<b>DELAYS</b>	All promises of shipment are estimated as closely as possible, and we will use our best efforts to ship within the time promised but do not guarantee to do so, and assume no liability for no doing so. Materials stated to be in stock are subject to prior sale.
<b>CANCELLATION &amp; SUSPENSION</b>	The order or contract is subject to cancellation or instructions to suspend or delay work or delivery only upon receipt of written notification and with our consent, and upon agreement to pay BF's adjustment charge. Order's for special products (usually "price of application" items) may be changed and or cancelled only upon receipt of written instructions with a full understanding and agreement to make payment for material used and work already performed.
<b>RETURN OF MATERIAL</b>	No product of our manufacture may be returned without written consent. All goods returned are subject to a handling charge plus freight in both directions and charges for any required reconditioning, unless otherwise specified in writing by BF.
<b>PATENTS</b>	The Purchaser will indemnify and hold harmless BF against and from any claims, costs (including attorneys fees) and liabilities arising out of any suit alleging infringement of any United States by any product supplied by BF under the contract and made in accordance with the design and or specification furnished by the Purchaser to BF.
<b>GOVERNING LAW</b>	The contract shall be governed by, construed, and enforced in accordance with the laws of the Commonwealth of Pennsylvania.
<b>NO WAIVER</b>	The failure of BF to insist, in any one or more instances upon the performance of any of the terms, covenants, or conditions of the contract or to exercise any right thereunder shall not be construed as a waiver or relinquishment of the future performance of any such term, covenant or condition or the future exercise of such rights, nor shall it be deemed to be a waiver or relinquishment of any other term, covenant, or condition or the exercise of any other rights under the contract.
<b>DIES, TOOLS AND PATTERNS</b>	Dies, tools and patterns required to produce the article quoted on shall remain the property of BF. Preparation charges for dies, tools and patterns represent only a portion of cost. Payment of such charge does not give you any right, title, or interest in such dies, tools, or other products of preparation. We will not be responsible for retention of dies or patterns on which no orders are received for two years or more.
<b>FORCE MAJEURE</b>	Any delays in or failure of performance of BF shall not constitute default or give rise to any claims for damages if and to the extent that such delay or failure is caused by occurrences beyond the control of BF, including but not limited to acts of God or the public enemy, expropriation or confiscation of facilities, compliance with any order or request of any governmental authority, acts of war, rebellion or sabotage or damage resulting therefrom, embargoes or other export restrictions, fires, floods, explosions, accidents, breakdowns, riots or strikes or other conceived acts of workmen, whether direct or indirect, or any other causes whether or not of the same class or kind as those specifically above named which are not within the control of BF and which by the exercise of reasonable diligence, BF, is unable to prevent or provide against.
<b>PURCHASER'S ACCEPTANCE OF ABOVE CONDITIONS</b>	The contract shall be subject to the terms and conditions contained or referred to in BF's price schedule, quotation or order acknowledgment and to no others whatsoever. No waiver, alteration, or modification of the terms and conditions in this price schedule, quotation or order acknowledgment shall be binding unless in writing and signed by an authorized representative of BF.

Note: The material in this catalog is for general information. For specific performance data and proper material selection, consult your Bonney Forge representative. Although every attempt has been made to ensure that the information contained in this catalog is correct, Bonney Forge reserves the right to change designs, materials or specifications without notice.