

Fig. 189

Straight Eye Socket

Size: 3/8"

Material: Galvanized steel

Service: Attachment to structure to connect threaded hanger rod.

Approvals: UL and ULC Listed, and FM Approved.

Installation:

- Thread rod completely into hanger. Secure rod by tightening jam nut against bottom of hanger.
- Secure hanger to structural member with recommended fasteners.

Features:

- Pre-formed threads for easy rod assembly.

Ordering: Specify rod size, figure number and name.



Description	Pipe Sizes	Rod Size	Max. Load
Straight Eye Socket Hanger	3/4" - 4"	3/8-16 UNC	250 lbs.

FASTENERS		
Description	Quantity	Pipe Size
#14 x 2" Wood Screw	2	*3/4" - 2"
1/2" x 3" Lag Screw	*1	3/4" - 4"
3/8-16 UNC Jam Nut	1	3/4" - 4"

* Lag screw not required for 3/4" - 2" pipe sizes using the alternate option of (2) wood screws.

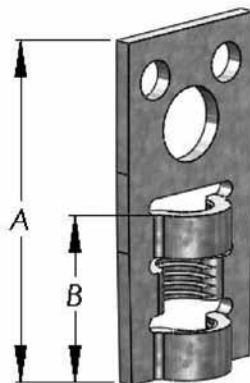
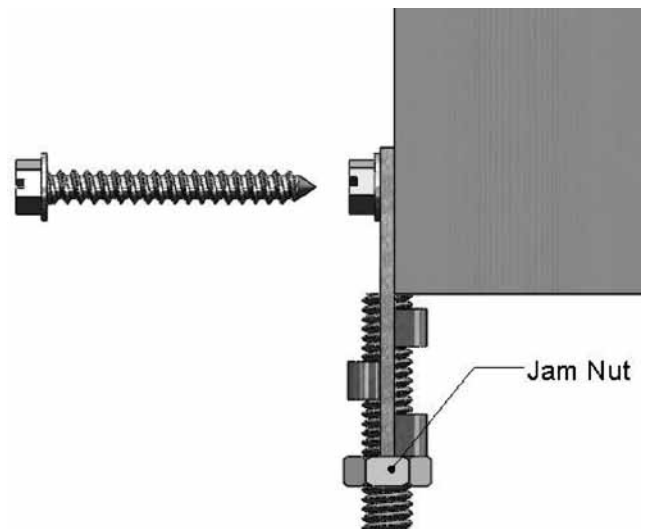

FIG. 189: DIMENSIONS (IN)	
A	B
2.28	1.10



Notes:

1. For fire protection installation follow the requirements of National Fire Protection Association, NFPA-13 and local codes.
2. To assure proper performance, installer is responsible for:
 - a. Structural integrity of attachment member to safely handle load requirements.
 - b. Securely tightening jam nut on the hanger rod.

- Table of Contents
- General Notes
- Copper Tubing Hangers
- Stainless Steel Hangers
- CPVC Pipe Hangers
- Pipe Rings
- Clevis Hangers
- Steel Pipe Clamps
- Socket Clamps
- Beam Clamps
- Structural Attachments
- Brackets**
- Ceiling Plates & Flanges
- Concrete Inserts & Attachments
- Hanger Rods
- Rod Attachments
- Bolts, Nuts, Pins & U-Bolts