

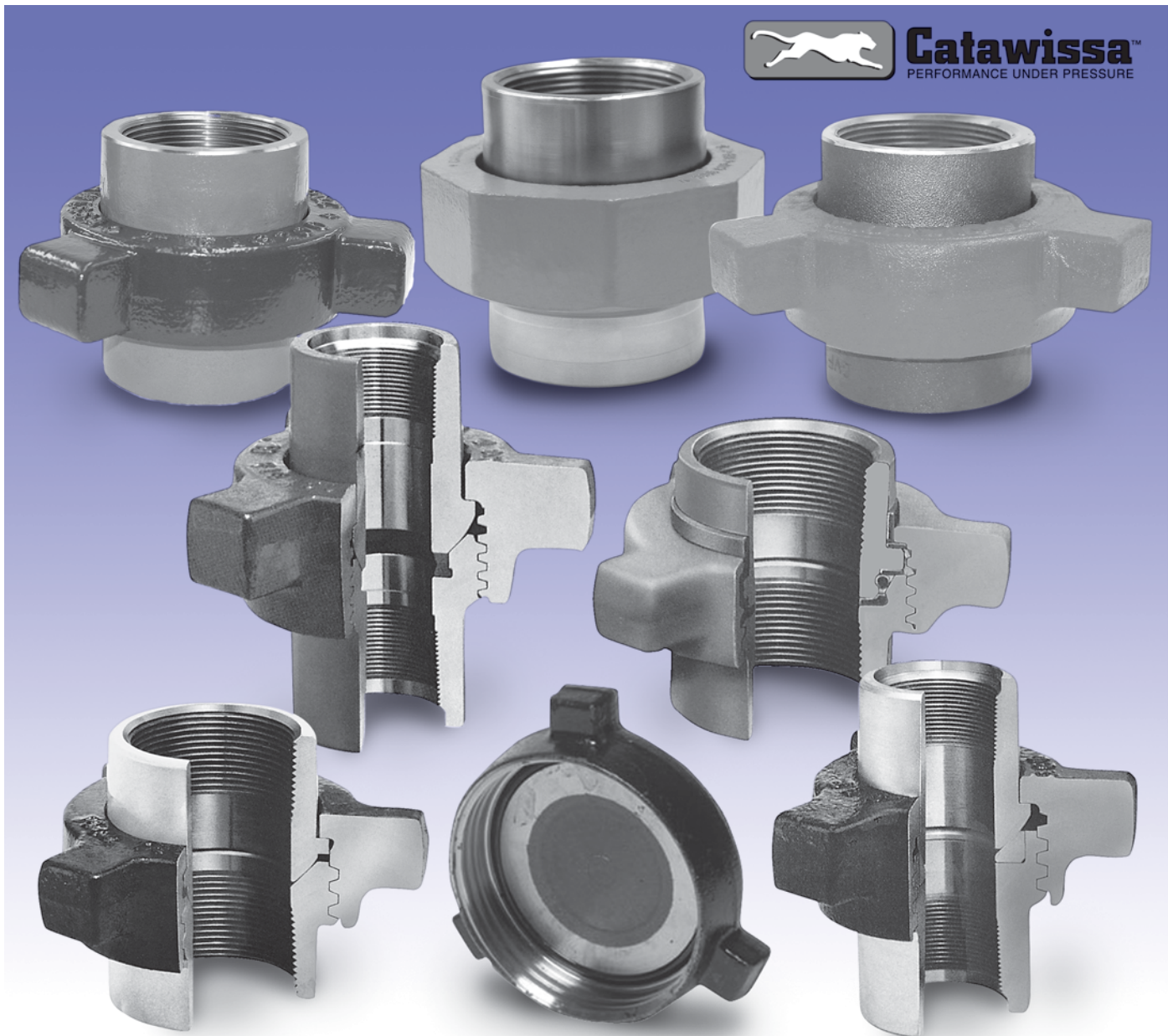

Catawissa™
PERFORMANCE UNDER PRESSURE



Malleable Iron

Cast Iron

Small Steel
Fittings

Pipe Nipples &
Pipe Couplings

Forged Steel
Fittings & Unions

Anvilets

Catawissa

J.B. Smith Products

Material

ASTM A29, A105, A395, A536

Full Traceability:

All Catawissa Oilfield Wing Unions are fully traceable and are available with complete mill certifications upon request.

Interchangeability:

All Catawissa Oilfield Unions are machined to rigid quality standards ensuring that like components of the same size, figure number and pressure rating are fully interchangeable in the field. Catawissa Oilfield Unions are interchangeable with most leading union manufacturers.

Standard Service:

Catawissa Unions are available for Standard Service. Catawissa Oilfield Unions meet or exceed National Association of Corrosion Engineers standard NACE MR-01-75 and API RP-14E, and are made in an ISO 9001-2008 certified facility. (Sour gas unions are available upon request only.)

Full Range of End Connections:

Catawissa Oilfield Wing Unions are also available in threaded ends as well as butt weld and non-pressure seal ends. When you choose Catawissa you receive the utmost in quality, the widest selection and unmatched on-time deliveries.

