

Fig. 260 ISS

Clevis Hanger with Insulation Saddle System

Size Range: 1/2" through 12" pipe and accommodates up to 2" of insulation.

Material: Carbon steel with high impact glass reinforced polypropylene saddle and carbon steel pipe spacer.

Finish: Plain or Galvanized Clevis Hanger

Service: Recommended for the suspension of stationary insulated chilled or hot water pipe lines.

Maximum Temperature: 40° F to 200° F

Approvals: Dual Fire Ratings, UL E94 VO and ASTM E84 Class 1 25/60.

Installation: Hanger load nut above clevis must be tightened securely to assure proper performance. Position the pipe on the saddle. Notch insulation to fit around the saddle. Square cut adjoining insulation and butt the insulation ends to each other. Insulation joint is coated, caulked and taped following standard insulation practice used on flanges and valves.

Adjustment: Vertical adjustment without removing the hanger may be made 7/8" through 2 3/8" varying with the size of the clevis. Tighten all nuts after adjustment.

Features: V-Block design cradles pipe through out the entire erection process. Clevis bolt spacer included as standard keeps the clevis lower strap from collapsing. Eliminates:

- Wood blocks and standard shields
- Costly calcium silicate inserts
- Re-leveling of piping at each individual hanger after insulation is completed.

Ordering: Specify size number, pipe size, insulation thickness, figure number name and finish.



FIG. 260 ISS SIZING TABLE						
Pipe Size	Insulation Thickness					
	1/2"	3/4"	1"	1 1/2"	2"	
(Size Number)						
1/2	2	2	3	—	—	
3/4	2	3	3	—	—	
1	2	3	3	—	—	
1 1/2	3	4	4	—	—	
2	4	4	5	—	—	
2 1/2	5	5	5	6	8	
3	5	5	5	6	8	
3 1/2	5	6	6	8	8	
4	6	6	8	8	8	
5	8	8	8	10	10	
6	10	10	10	10	10	
8	12	12	12	12	12	
10	14	14	14	14	16	
12	16	16	16	16	—	

FIG. 260 ISS SIZING TABLE					
Copper Tube Size	Insulation Thickness				
	1/2"	3/4"	1"	1 1/2"	2"
(Size Number)					
3/8	2	2	3	—	—
1/2	2	2	3	—	—
5/8	2	2	3	—	—
3/4	2	2	3	—	—
1	2	3	3	—	—
1 1/4	3	3	3	—	—
1 1/2	3	3	4	—	—
2	4	4	4	—	—
2 1/2	4	5	5	6	—
3	5	5	5	6	8
3 1/2	5	5	6	8	8
4	6	6	8	8	8
5	8	8	8	8	10
6	8	10	10	10	10
8	10	10	12	12	12

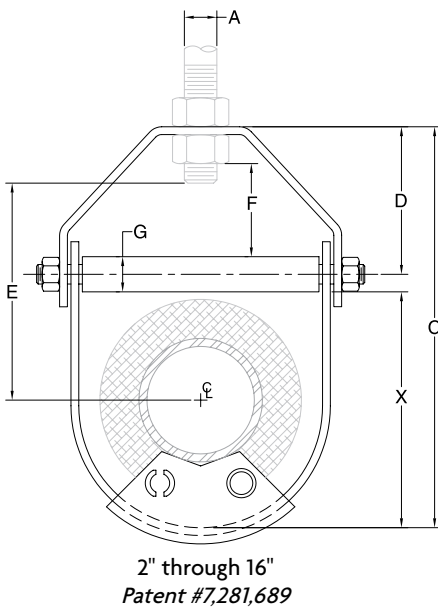

FIG. 260 ISS: LOADS (LBS) • WEIGHTS (LBS) • DIMENSIONS (IN)								
260 ISS Size Number	*Max Load	Weight	Rod Size A	C	**Rod Take Out E	Adjust. F	G	X
2	550	0.73	3/8	4 1/2	2 5/8	7/8	1/4	2 3/8
3		1.32	1/2	6 1/2	4 1/16	1 7/16	3/8	3 5/8
4		1.83	5/8	7 13/16	4 1/2	1 1/2		4 1/2
5	2.44	8 15/16		5 1/2	1 3/4	5 11/16		
6	750	3.81	3/4	10 1/4	5 3/4	1 1/2	1/2	6 11/16
8	1100	5.60		12 11/16	7 3/16	1 3/4		8 13/16
10		9.73	7/8	15 1/4	8 7/16	1 7/8	5/8	10 3/4
12		13.80		17 15/16	10 1/8	2 9/16		12 7/16
14	1700	15.60	1	19 9/16	10 11/16	2 1/2	3/4	14 7/16
16		26.81		22	12	2 3/8	1	16 5/16

* Max load exceeds dead weight load requirement of pipe at max span, except 14 and 16 where max load is based on industry standard spacing of 14. Further information on typical pipe spans and piping weight per length can be found on pages 249 and 251, respectively.

** Based on maximum insulation thickness, variations due to pipe size and insulation thickness may occur.