

# SOCKET CLAMPS

## Fig. 595

### Socket Clamp for Ductile Iron or Cast Iron Pipe

**Size Range:** 4" through 24"

**Material:** Two carbon steel half bands and four bolts and nuts.

**Finish:** Plain or Galvanized

**Service:** Clamps ductile or cast iron mechanical joint piping or mechanical joint or socket joint fittings together to prevent separation or distortion of pipe line under excessive water pressure.

**Approvals:** Complies with Federal Specification A-A-1192A (Type 8), ANSI/MSS SP-69 and MSS SP-58 (Type 8). Complies with the requirements of the National Fire Protection Association Standard NFPA-24 for Outside Protection.

**Ordering:** Specify pipe size, figure number, name and finish.



## Fig. 594

### Socket Clamp Washer

Two cast iron or steel washers, Fig. 594, are used with each Fig. 595 socket clamp and these must be ordered separately.

**Ordering:** Specify washer size, figure number, name and finish.

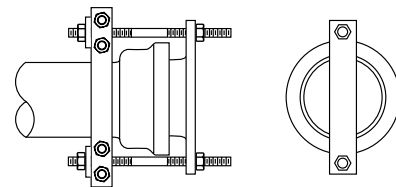
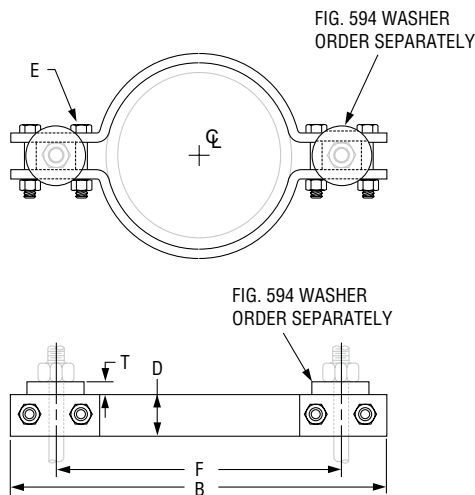

Plug Strap for Bell End of Pipe

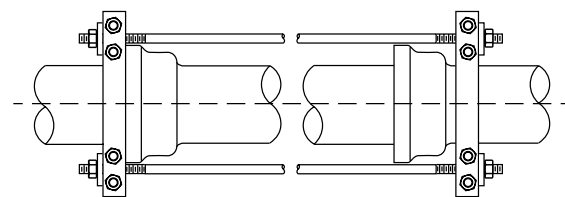

Pipe Anchor

### FIG. 595, FIG. 594: LOADS (LBS) • WEIGHT (LBS) • DIMENSIONS (IN)

D.I./C.I. Pipe Size	Max Test Pressure (PSI)	Force* On Clamp	Weight		Pipe O.D.	B	D Width	Bolt Dia. E	F	T	Fig. 594 Washer Rod Dia.
			Fig. 595 Clamp	Fig. 594 Washer							
4	250	4,550	12.8	1.1	5	14 <sup>5</sup> / <sub>8</sub>	2	5/8	9 <sup>5</sup> / <sub>8</sub>	5/8	3/4
6		9,340	14.6		7 <sup>7</sup> / <sub>8</sub>	16 <sup>7</sup> / <sub>8</sub>					
8		16,080	23.6		9 <sup>5</sup> / <sub>16</sub>	19 <sup>1</sup> / <sub>8</sub>					
10		24,180	29.3	11 <sup>1</sup> / <sub>2</sub>	21 <sup>3</sup> / <sub>8</sub>	2 <sup>1</sup> / <sub>2</sub>	3/4	14 <sup>1</sup> / <sub>8</sub>			
12		34,230	40.3	13 <sup>1</sup> / <sub>2</sub>	25 <sup>1</sup> / <sub>8</sub>						
14	120	22,200	53.9	2.7	15 <sup>3</sup> / <sub>4</sub>	28 <sup>1</sup> / <sub>4</sub>	3	7/8	19 <sup>5</sup> / <sub>8</sub>	3/4	
16	115	27,760	76.5		17 <sup>7</sup> / <sub>8</sub>	31 <sup>3</sup> / <sub>8</sub>					
18	100	23,900	94.3	4.3	20	35 <sup>1</sup> / <sub>8</sub>	4	1	22 <sup>3</sup> / <sub>8</sub>		1 <sup>1</sup> / <sub>8</sub>
20	75	27,500	109.8		22 <sup>1</sup> / <sub>8</sub>	37 <sup>3</sup> / <sub>4</sub>			4 <sup>1</sup> / <sub>2</sub>		
24	50	26,200	148.6		5.8	26 <sup>3</sup> / <sub>8</sub>	44 <sup>1</sup> / <sub>4</sub>	5			1 <sup>1</sup> / <sub>2</sub>
									36	1 <sup>1</sup> / <sub>4</sub>	1 <sup>1</sup> / <sub>2</sub>

\*Refers to Hydrostatic Test