

ACTUATORS AND CONTROLS

"Acutorque" Stainless Steel Actuator

DESIGN AND CONSTRUCTION

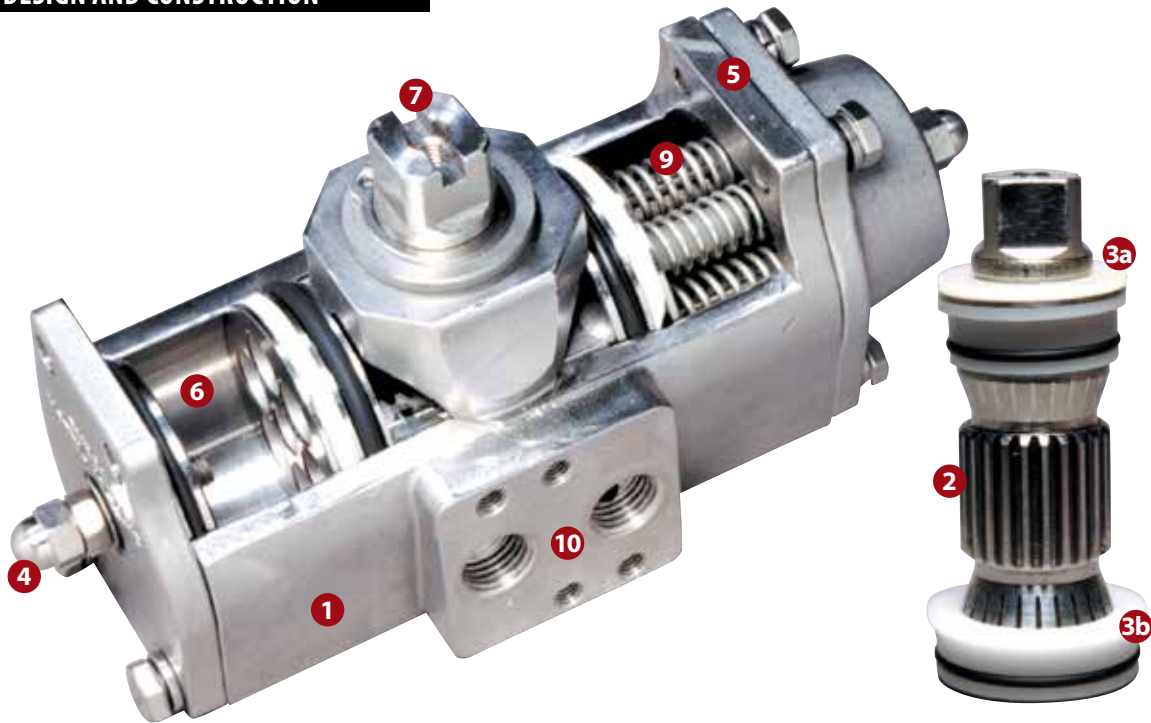

1. INVESTMENT CAST BODY

Assures manufacturing of other special alloys, such as Monel

2. UNIQUE DRIVE PINION

One piece stainless steel alloy shaft, precision machined gear and teeth for precise control

3. BEARINGS

Replaceable top and bottom TFE Pinion Bearings to ensure low friction, stability above 400°F, and chemical resistance

4. TRAVEL STOPS

Provides +/-4° travel adjustment in outboard direction

5. ACCESSORY MOUNTING

Manufactured to NAMUR to provide international standardized mounting

6. STAINLESS STEEL PISTONS

Precision cast pistons are guided through full face engagement with the pinion and piston guide

7. NAMUR SLOTTED SHAFT

Standard to provide a self-centering positive drive for positioners, a variety of switches

8. ACTUATOR MOUNTING

Manufactured in accordance with ISO 5211 to ensure mounting the actuator directly on valves

9. PRE-LOADED CARTRIDGES

Converts a standard double acting actuator to a spring return unit by simply removing the end caps and adding the spring cartridges

10. NAMUR SOLENOID MOUNTING

International standard for direct mounting of solenoid valves

ACTUATORS AND CONTROLS

Operation – “Acutorque” Stainless Steel Actuator

The Apollo® Acutorque actuator is manufactured with an integral and internal air manifold. The solenoid mounting pad is manufactured to Namur dimensional standards as to allow for the direct mounting of various manufacturers' solenoid valves and other flow control devices. For applications not requiring a direct mount solenoid valve, ports are tapped to NPT standards (American National Standard taper threads).

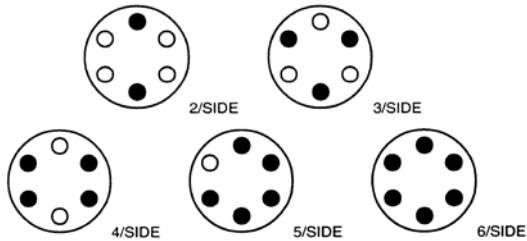

REVERSE ROTATION

When required, a clockwise rotation of the drive pinion, by means of air to PORT A can be achieved by reversing the pistons inside the actuator body (rotate 180 degrees).

SPRING CONFIGURATION

Each Acutorque actuator comes with a complete spring pack (6 springs per side with nylon retainers) unless otherwise specified. When less than the full spring pack is desired for various torque outputs (see torque chart); springs can be removed from the actuator end caps. It is very important that springs can be arranged in a symmetrical manner (positioned as shown) so that unwarranted side-load does not occur between the pistons and actuator body. *CAUTION: Refer to operation and maintenance instructions before disassembly and removal of springs.*

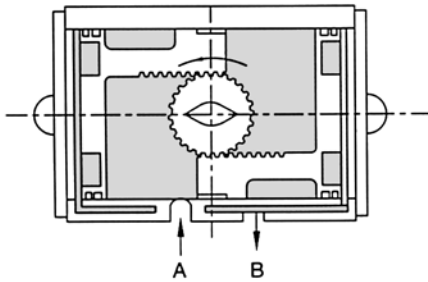

Air to PORT A: Pressure applied enters center of chamber forcing the pistons outward and rotating the drive pinion in a counter-clockwise direction and forcing exhaust air out of PORT B.

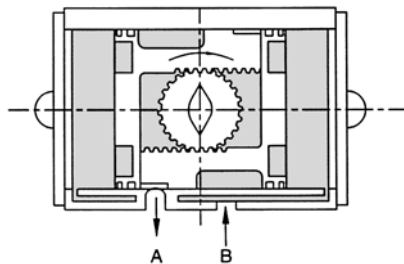

Air to PORT B: Air pressure enters the outer chambers forcing the pistons inward and rotating the drive pinion in a clockwise direction while forcing exhaust air out of PORT A.

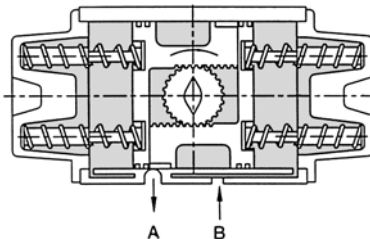

Loss of air pressure in the center chamber allows energy in the compressed springs to force the pistons inward, resulting in a clockwise rotation of the drive pinion while exhaust air leaves via PORT A.

ACTUATORS AND CONTROLS

Features – “Acutorque” Stainless Steel Actuator

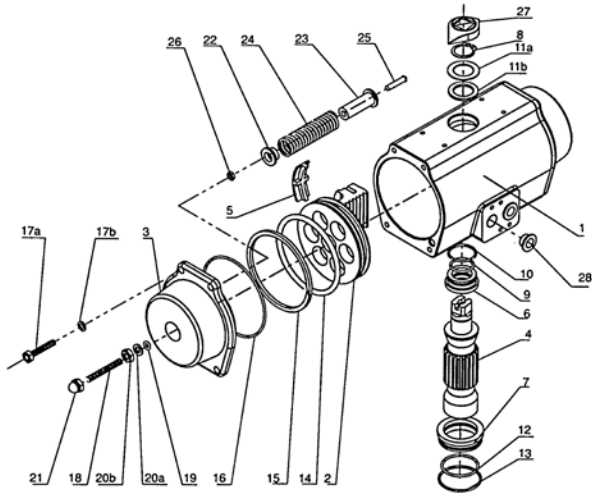

CORROSION RESISTANCE

All metal components are cast or machined from Stainless Steel or Monel, which offers excellent resistance to most corrosive chemicals as well as industrial atmospheres.

NO LUBRICATION

All actuators are factory lubricated for the optimum life of the actuator under normal conditions. Teflon® piston bearings are used because of their self-lubricating properties.

SIMPLE MAINTENANCE

Each actuator is designed for ease of maintenance. Should you wish to change a spring rating or completely rebuild a unit, total disassembly and reassembly is easily performed in just minutes with standard shop tools.

ISO/NAMUR MOUNTING

By using ISO/Namur standards, our actuators lend themselves to a host of various manufacturers' direct mount accessories. Solenoid valves, limit switches, positioners, etc. bolt directly to the actuator and in turn reduces the cost of assembly and installation of automated packages. Flexibility for future system modifications is greatly enhanced.

QUALITY

Each part of the actuator must pass a stringent quality test before it can be incorporated into an assembly. All materials used in construction must be certified and tested to prove their proper composition. Every cast part must pass an X-ray test before proceeding to the machining process. After machining, every part is dimensionally evaluated to assure it meets acceptable tolerance.

SAFETY

All actuator bodies and end caps are investment cast stainless steel, rugged and built to last. It may be argued that the mechanical properties of stainless steel permit the ability to use this wall tubing in the construction of an actuator. However, that is not the case with our actuator. Thick wall castings mean protection for actuator internal porting and components as well as maintenance and operating personnel. Our unique drive pinion design ensures blowout proof protection. Spring retainers are incorporated to allow safe removal of end caps during spring torque rating change or rebuild process.

GRADE OF STAINLESS STEEL

Body & End Caps	304
Shaft	17-4 ph
Piston	303
Bolts	18-8

Part	Qty	Material
1 Body	1	304 Stainless Steel
2 Piston	2	303 Stainless Steel
3 End Caps-Double Acting	2	Stainless Steel
4 Drive Pinion	1	17-4 Stainless Steel
5 Guide Bearing Plate	2	Nylon 6
6 Pinion Bearing Top	1	Teflon
7 Pinion Bearing Bottom	1	Teflon
8 Snap Ring	1	Stainless Steel
9 O-Ring-Inner Top	1	Viton
10 O-Ring-Outer Top	1	Viton
11a Washer	1	Stainless Steel
11b Bearing	1	Nylon 6
12 O-Ring-Inner Bottom	1	Viton
13 O-Ringer-Outer Bottom	1	Viton
14 O-Ring-Piston	2	Viton
15 Bearing-Piston	2	Nylon 6

Part	Qty	Material
16 O-Ring-End Cap	2	Nitrile
17a Bolts-End Cap	8	Stainless Steel
17b Spring Bearing	8	Stainless Steel
18 Adjusting Travel Stop	2	Stainless Steel
19 O-Ring-Travel Stop	2	Nitrile
20a Washer	2	Stainless Steel
20b Nut-Travel Stop	2	Stainless Steel
21 End Nut-Travel	2	Stainless Steel
22 Spring Retainer (S)	*	Nylon 6
23 Spring Retainer (L)	*	Nylon 6
24 Spring	*	Plated CS
25 Spring Screw	*	Stainless Steel
26 Spring Nut	*	Stainless Steel
27 Positioner Indicator	1	Nylon
28 Plug	2	Nylon 6

ACTUATORS AND CONTROLS

Dimensional Data – “Acutorque” Stainless Steel Actuator

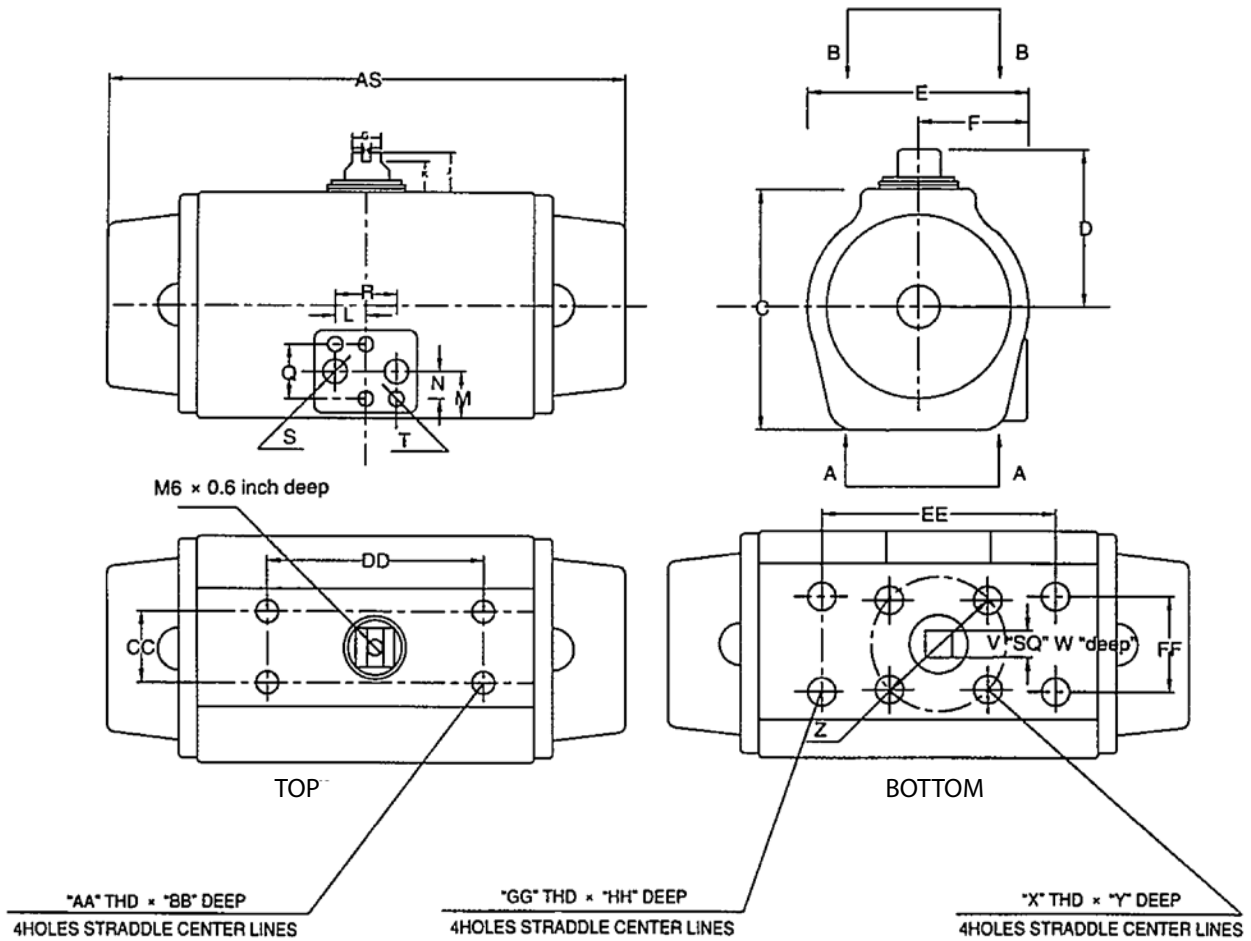

MOUNTING DIMENSIONS

Model		R	S	T	V	W	X	Y	Z	AA	BB	CC	DD	EE	FF	GG	HH
3SD04500	mm	24	1/4"NPT	M5	11	15	M5	8	42	M5	6	30	80	88.9	31.75	M5	8
3SS04560	in	0.95	1/4"NPT	M5	0.4	0.59	M5	0.31	1.65	M5	0.24	1.18	3.15	3.5	1.25	M5	0.31
3SD06000	mm	24	1/4"NPT	M5	14	15	M6	8	50	M5	6	30	80	88.9	31.75	M6	8
3SS06060	in	0.95	1/4"NPT	M5	0.55	0.59	M6	0.31	1.97	M5	0.24	1.18	3.15	3.5	1.25	M6	0.31
3SD08500	mm	24	1/4"NPT	M5	19	17	M8	12	70	M5	6	30	80	114	38	M8	12
3SS08560	in	0.95	1/4"NPT	M5	0.75	0.68	M8	0.47	2.75	M5	0.24	1.18	3.15	4.5	1.5	M8	0.47
3SD10500	mm	24	1/4"NPT	M5	19	20	M8	12	70	M5	6	30	80	114	38	M8	12
3SS10560	in	0.95	1/4"NPT	M5	0.75	0.79	M8	0.47	2.75	M5	0.24	1.18	3.15	4.5	1.5	M8	0.47
3SD12500	mm	24	1/4"NPT	M5	22	30	M8	18	102	M5	8	30	130	NA	50.8	NA	NA
3SS12560	in	0.95	1/4"NPT	M5	0.87	1.2	M8	0.71	4.02	M5	0.31	1.18	5.12	NA	2	NA	NA
3SD14000	mm	24	1/4"NPT	M5	22	27	M10	18	102	M5	8	30	130	NA	50.8	NA	NA
3SS14060	in	0.95	1/4"NPT	M5	0.87	1.06	M10	0.71	4.02	M5	0.31	1.18	5.12	NA	2	NA	NA
3SD17000	mm	24	1/4"NPT	M5	32	36	M12	24	125	M5	8	30	130	NA	76	NA	NA
3SS17060	in	0.95	1/4"NPT	M5	1.26	1.42	M12	0.95	4.92	M5	0.31	1.18	5.12	NA	3	NA	NA
3SD21000	mm	24	1/4"NPT	M5	36	43	M20	28	140	M5	8	30	130	NA	76	NA	NA
3SS21060	in	0.95	1/4"NPT	M5	1.42	1.69	M20	1.1	5.51	M5	0.31	1.18	5.12	NA	3	NA	NA

ACTUATORS AND CONTROLS

Double Acting Torque – “Acutorque” Stainless Steel Actuator

Actuator Model	Torque (Inch/Lbs) vs. Air Supply Pressure (PSI)					
	40	60	80	100	120	150
3SD04500	74	116	152	199	239	289
3SD06000	151	234	328	413	499	600
3SD08500	365	548	732	915	1097	1315
3SD10500	701	1068	1436	1829	2184	2632

Actuator Model	Torque (Inch/Lbs) vs. Air Supply Pressure (PSI)					
	40	60	80	100	120	150
3SD12500	1355	2069	2759	3449	4115	5168
3SD14000	2018	3032	4039	5046	6056	6615
3SD17000	2868	4050	5324	6640	7987	10042
3SD21000	5328	8462	11188	13884	16709	20929

DIMENSIONS

Model		AS	C	D	E	F	G	H	J	K	L	N	M	Q
3SD04500	mm	168	65	52.5	62.5	35	16	4	20	10	12	16	23	32
3SS04560	in	6.61	2.56	2.07	2.46	1.38	0.63	0.16	0.79	0.39	0.47	0.63	0.91	1.26
3SD06000	mm	180	81	60.5	74	39	16	4	20	10	12	16	23	32
3SS06060	in	7.09	3.19	2.38	2.91	1.54	0.63	0.16	0.79	0.39	0.47	0.63	0.91	1.26
3SD08500	mm	222	108	74	100.5	52	16	4	20	10	12	16	24	32
3SS08560	in	8.74	4.25	2.91	3.96	2.05	0.63	0.16	0.79	0.39	0.47	0.63	0.95	1.26
3SD10500	mm	290	133	86.5	117	58.5	16	4	20	10	12	16	30	32
3SS10560	in	11.42	5.24	3.41	4.61	2.3	0.63	0.16	0.79	0.39	0.47	0.63	1.18	1.26
3SD12500	mm	390	155	110.2	136	68	20	4	30.5	10.5	12	16	40	32
3SS12560	in	15.5	5.02	3.59	5.65	2.91	0.79	0.16	1.2	0.41	0.47	0.63	1.57	1.26
3SD14000	mm	420	176	116.5	156	79	20	4	30.5	10.5	12	16	40	32
3SS14060	in	16.54	6.93	4.59	6.14	3.11	0.79	0.16	1.2	0.41	0.47	0.63	1.57	1.26
3SD17000	mm	538	210	131.5	193	98	20	4	30.5	10.5	12	16	50	32
3SS17060	in	21.18	8.27	5.18	7.6	3.86	0.79	0.16	1.2	0.41	0.47	0.63	1.97	1.26
3SD21000	mm	698	258	156	236	120	32	4	30.5	10.5	12	16	68	32
3SS21060	in	27.48	10.16	6.14	9.29	4.72	1.26	0.16	1.2	0.41	0.47	0.63	2.68	1.26

ACTUATORS AND CONTROLS

Spring Return Torque – “Acutorque” Stainless Steel Actuator

Actuator Model	Spring Set#*	Spring Stroke		Torque (Inch/Lbs) vs. Air Supply Pressure (PSI)											
				40		60		80		100		120		150	
		0	90	0	90	0	90	0	90	0	90	0	90	0	90
3SS045X0	2	34	21	56	43	98	84	136	121	178	162	220	203	256	230
	3	49	29	45	24	88	65	126	93	165	142	204	179	238	204
	4	71	43			72	42	115	90	154	126	196	163	218	175
	5	88	52					109	76	147	109	182	184	209	156
	6	107	64					97	58	135	91	172	103	190	129
3SS060X0	2	61	37	101	79	167	140	237	214	304	278	369	345	435	399
	3	93	55	84	48	147	107	219	185	284	248	352	315	405	350
	4	124	75			129	77	203	157	268	219	331	276	380	315
	5	156	93			110	45	187	131	250	189	315	250	359	272
	6	186	112					171	102	233	158	296	218	335	228
3SS085X0	2	172	93	275	206	450	369	645	572	821	744	999	919	1175	1065
	3	257	139	236	126	403	281	602	493	773	661	949	884	1105	945
	4	343	185			354	192	558	414	729	574	901	743	1042	825
	5	428	232					516	303	683	490	853	651	975	705
	6	515	288					473	258	636	405	800	564	915	580
3SS105X0	2	325	182	527	394	852	703								
	3	483	256	443	246	759	537	1137	939						
	4	643	358			665	369	1051	790	1374	1099	1703	1413	1975	1570
	5	805	447			556	119	974	641	1291	934	1615	1241	1852	1340
	6	964	537					888	493	1195	777	1519	1077	1705	1100
3SS125X0	2	628	343	1025	730	1724	1435								
	3	945	510	860	425	1545	1118	2310	1864						
	4	1259	687			1370	806	2068	1480	2720	2158	3333	2450	4166	3062
	5	1579	865			1199	483	1875	1160	2545	1835	3157	2185	3947	2728
	6	1895	1040					1690	850	2371	1528	2915	1846	3628	2310
3SS140X0	2	905	520	1478	1092	2469	2088								
	3	1355	780	1215	642	2210	1639	3195	2620						
	4	1808	1035			1956	1197	2935	2180	3960	3175	5000	4000	6250	5010
	5	2257	1301			1692	739	2680	1750	3700	2748	4608	3425	5760	4290
	6	2708	1562					2441	1279	3444	2290	4280	2852	5362	3568
3SS170X0	2	1227	738	1985	1494	3411	2923								
	3	1830	1092	1824	1087	3045	2347	3945	3626						
	4	2417	1446			2695	1713	4012	3035	4307	4291	6305	5221	7890	6526
	5	3044	1811			2329	1104	3647	2417	4934	3700	6000	4608	7495	5760
	6	3653	2166					3295	1817	4579	3093	5719	3750	7149	4680
3SS210X0	2	2425	1388	4080	2988	7149	6112								
	3	3640	2080	3388	1831	6456	4899	9205	7626						
	4	4857	2769			5750	3675	8510	6438	11150	9082	9231	12900	16100	12835
	5	6060	3465			5070	2475	7772	5224	10400	5160	7835	12000	15000	11030
	6	7270	4165					7125	4010	9700	4238	6616	10909	13650	9150

* X in Actuator Model is Spring Set