

COMMERCIAL PRODUCTS CATALOG

Water Pressure Reducing Valves

PRH (36H) SERIES



HIGH FLOW DESIGN FOR LARGE COMMERCIAL APPLICATIONS

The Apollo® 36H reduces wasteful elevated supply pressures to a lower manageable pressure. Available with threaded or flange connections and optional rugged Y strainer.

FEATURES

- Approved to ASSE and CSA standards; listed with IAPMO
- Large yoke-type design aids flow and reduces pressure loss
- Initial pressure up to 400 psig
- Maximum temperature 180°F
- Integral by-pass relief protects against thermal expansion
- Bronze body & cage, stainless steel replaceable seat
- Sizes: 1/2", 3/4", 1", 1-1/4", 1-1/2", 2", & 3" NPT - threads (inlet and outlet): 2-1/2" & 3" also offered in 150 lb. flange
- Bottom access for easy inline repair
- Sealed cage is standard
- Stainless steel bolts, adjustment screws and spring
- **Lead Free** option (36HLF)
- Made in USA

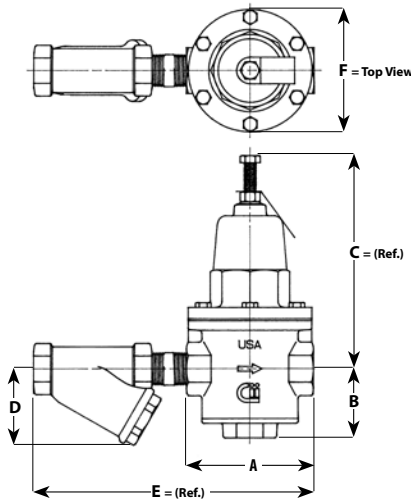

Size (in.)	A (in.)	B (in.)	C (in.)	D (in.)	E (in.)	F (in.)	Wt. w Strainer (lbs.)	Wt. w/o Strainer (lbs.)
NPT								
1/2"	4.13	2.25	7.00	1.88	8.38	4.00	7.0	6.00
3/4"	4.13	2.25	7.00	2.44	9.00	4.00	8.0	6.00
1"	4.81	2.31	7.50	4.00	10.25	4.69	12.0	8.00
1-1/4"	6.75	3.81	10.00	3.38	12.50	6.50	29.0	24.00
1-1/2"	6.75	3.19	10.00	3.88	13.13	6.50	29.0	23.00
2"	8.13	3.50	12.50	4.63	16.00	7.63	47.0	38.00
2-1/2"	8.13	3.50	12.50	5.94	16.69	7.63	49.0	37.00
3"	10.38	3.94	15.13	6.94	20.50	9.75	87.0	70.00
Flanged								
2-1/2"	10.38	3.50	12.50	7.13	21.69	7.63	105.0	55.00
3"	12.50	3.94	15.13	8.13	24.50	9.75	136.0	92.00

PART NUMBER MATRIX

36H			
36HLF - X	X	X	- OX
END CONNECTIONS	OPTIONS	SIZE	PRESSURE RANGE
2 - FNPT x FNPT (Standard)	0 - Standard	3 - 1/2"	01 - 25-75 psig (Standard)
7 - Flanged (2-1/2" - 3" only)	1 - With Y-Strainer	4 - 3/4"	02 - 10-35 psig
		5 - 1"	03 - 75-125 psig**
		6 - 1-1/4"	
		7 - 1-1/2"	
		8 - 2"	
		9 - 2-1/2"	** Can be adjusted to 75-165 psig
		0 - 3"	