

EXPLORE™ 4-LEG SERIES

SIXTH ROUND ACTIVITY TABLES

Allows for flexible learning environments as tables can be used alone or in circles of five, six or seven tables, or with rectangle tables to create a conference style layout.



FEATURES

- Individual student tables allow for highly flexible classrooms and can be used as individual desks, or quickly and easily reconfigured into small groups or large circles for collaborative work.
- Tables with rounded sides function like a joint and increase room flexibility by allowing for round configurations of five, six or seven tables. Tables with flat sides form a seamless circle of six tables.
- Student seating edge is scalloped to provide greater ergonomic access to the work space without having to over reach.
- Tables are available with 2.5" twin wheel casters, all with a locking brake, or with leveling glides for stationary configurations.
- Work surface is height adjustable from 22" to 32" in height in 1" increments on tables with casters. Tables with glides are height adjustable from 20" to 30".
- Unique flat oval tube steel base has telescoping legs for height adjustment and is constructed from 14-gauge steel.
- Base model features a 1", 45 lb. density, MDF substrate with laminated top and standard thermoplastic elastomer (TPE) t-mold edge band that is attached along the entire perimeter of the work surface. Premium finish models feature a 1", 45 lb. density MDF substrate with .03" HPL laminate top and .03" backer and a TPE t-mold edge.
- Work surface includes metal threaded inserts to mount the leg assemblies for a metal to metal connection that adds strength and greatly reduces the possibility screws will strip or fall out over time.
- Meets or exceeds ANSI BIFMA x5.5-2008 standards for tables and proudly made in the U.S.A. using union labor.

STANDARD FINISH OPTIONS

Work surface is available in Grey Mist laminate with matching Quartz trim or Natural Maple laminate with Aluminum trim. Powder paint steel bases are Aluminum and toe kicks are always Anthracite.



-ALGM
Grey Mist top and
Aluminum base



-ALMP
Natural Maple top and
Aluminum base

PREMIUM FINISH OPTIONS

EDU 2.0 products are available to order in any paint, trim and laminate offered by Bretford. Work surfaces may be specified with a 3mm thermoplastic (TPE) t-mold edge. To order product ordered in premium finish specify paint, laminate, edge detail, trim color.

Example: (shown below)

EDUS6W24C⁽¹⁾-OCE⁽²⁾-LEL⁽³⁾-01⁽⁴⁾-MW⁽⁵⁾

⁽¹⁾ = Base Model Number With Flat Sides

⁽²⁾ = Ocean Paint

⁽³⁾ = Leave Likatre Laminate

⁽⁴⁾ = 3mm Thermoplastic Elastomer (TPE) Edge

⁽⁵⁾ = Mission White Edge Finish

SHIPPING INFORMATION & UPC CODES

All tables ship ready to assemble in one carton pack.

Base Model	ALGM	ALMP
EDUS6W24-	0 96633 35500 6	0 96633 35501 3
EDUS6W24C-	0 96633 35502 0	0 96633 35503 7
EDUS6W30-	0 96633 35504 4	0 96633 35505 1
EDUS6W30C-	0 96633 35506 8	0 96633 35507 5
EDUSC6W24-	0 96633 35701 7	0 96633 35702 4
EDUSC6W24C-	0 96633 35703 1	0 96633 35704 8
EDUSC6W30-	0 96633 35705 5	0 96633 35706 2
EDUSC6W30C-	0 96633 35707 9	0 96633 35708 6



DIMENSIONS

Overall Tables with Glides:

EDUS6W24- & EDUSC6W24-: 49"w x 25"d x 20"-30"h

EDUS6W30- & EDUSC6W30-: 55"w x 31"d x 20"-30"h

Overall Tables with Casters:

EDUS6W24C- & EDUSC6W24C-: 49"w x 25"d x 22"-32"h

EDUS6W30C- & EDUSC6W30C-: 55"w x 31"d x 22"-32"h

Distance Between Legs:

	24"D Tables	30"D Tables
Front Legs:	33 ^{1/4} "	38"
Rear Legs:	21 ^{1/2} "	21 ^{1/4} "
Side Legs:	16 ^{3/4} "	22 ^{3/4} "

Individual Table Dimensions:

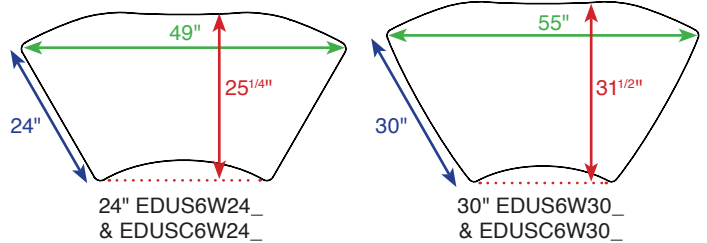

Configured Six Table Group Dimensions:

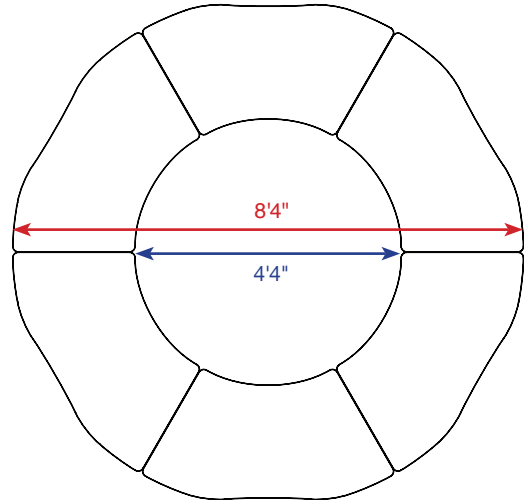

24" EDUS6W24-
& EDUSC6W24-

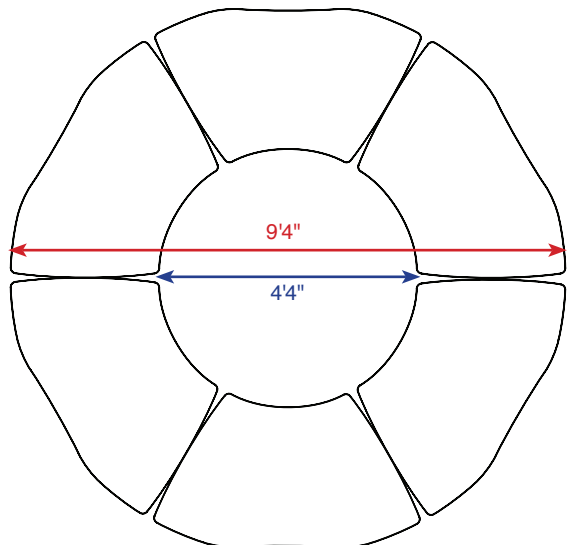

30" EDUS6W30-
& EDUSC6W30-

ENVIRONMENTAL & SAFETY SPECIFICATIONS

GREENGUARD CERTIFIED

EDU2.0 products are pending certification to GreenGuard Indoor Air Quality for Children and Schools.

EDGE TRIM OPTIONS

Standard edge T-mold trim is constructed from thermoplastic elastomer (TPE) which, unlike PVC, is non-toxic, generates low pollution during manufacturing, is additive and phthalate free, is recyclable at the end of the product life cycle, or will break down in a landfill.

POWDER COAT PAINT

All steel components are finished using a powder coat paint that greatly reduces VOCs while providing superior durability.

RECYCLED CONTENT

The work surface uses a MDF substrate that contains an average of 70% recycled content. Steel components are constructed with prime steel and feature a 25% to 35% post-consumer recycled content. Steel components are 100% recyclable at the end of the product life cycle.

ANSI-BIFMA TESTED

Tables are tested to and meet or exceed the ANSI-BIFMA x5.5-2008 standards for tables.

FOUR LOCKING CASTERS

Mobile EDU2.0 tables feature all four casters with locking brakes for stable configurations.

CONSTRUCTION SPECIFICATIONS

BASE

Upper and lower leg assemblies are constructed with 14-gauge flat oval tubing, which are formed using a CNC tube bender, and features arc welded connections to the mounting plate with two 3/16" gussets added for strength and support. The upper leg assembly mounts to the underside of the work surface with seven screws through a 3/16" thick steel plate. Each leg screw threads into metal inserts in the underside of the work surface for a strong fit. The lower leg assembly telescopes inside the upper assembly, allowing for height adjustability from 20" to 30" on tables with glides and 22" to 32" on tables with casters. Legs adjust in 1" increments. The lower leg is available with the choice of 2.5" diameter twin wheel casters, all with locking brakes, or with 1" adjustable leveling glides.

WORK SURFACE

Work surfaces on base models feature a 1" thick, 45 lb.. density melamine top and premium finish models feature a 1" thick, 45 lb.. density core with .03" high-pressure laminate top and .03" backer. Work surfaces are available with strait side edges for a tight fit when configured together, or with rounded side edges, which allow tops to roll along the edge and create greater flexibility when configured. Tables with strait side edges may be configured into a circle of six tables and tables with rounded side edges may be configured into a circle of five, six or seven tables. Each table is designed to seat one child or adult. All models come with a 3mm TPE t-mold. The underside of the work surface includes 28 metal inserts that align with the leg mounting plates.

WARRANTY

Bretford warranties EDU2.0 Explore Series Tables for 12-years, at date of shipment, against defects from materials or workmanship. Electrical and data components, gas shocks, and fabric feature a 1-year warranty.

MADE IN THE USA

EDU2.0 tables are made at Bretford's Chicago area manufacturing facility, employing union labor.



11000 SEYMOUR AVENUE
FRANKLIN PARK, ILLINOIS 660131 USA
TOLL FREE PHONE 800-521-9614
PHONE 847-678-2545
TOLL FREE FAX 800-343-1779
FAX 847-678-0852
WWW.BRETTFORD.COM