

FASTENERS

FLATTENED END LAG SCREW

Figure 11

The Figure 11 is normally used with perforated extension bar to support light duty loads from wooden structures. Comes with bolt and nut.

Material: Carbon Steel.

Finish: Plain.

Ordering: Specify size, and figure number. For Metric applications specify Figure M11.

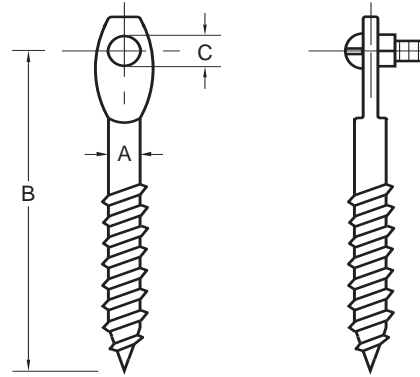

FIGURE 11 – FLATTENED END LAG SCREW

SIZE A	B	C	WEIGHT EACH
¼	3	⅜	0.04
M6	76	M5	0.02
⅜	3	¼	0.07
M8	76	M6	0.03
⅝	4	¼	0.10
M10	102	M6	0.05

TOGGLE BOLT

Figure 59

The spring toggle bolt is the most popular hollow wall fastener used today. The wings are fitted with coil springs that open when inserted into the wall. Gravity is not a factor making it possible to be used in any position.

Material: Steel.

Finish: Electro-Galvanized.

Ordering: Specify figure number, diameter, and length. For Metric applications specify Figure M59.

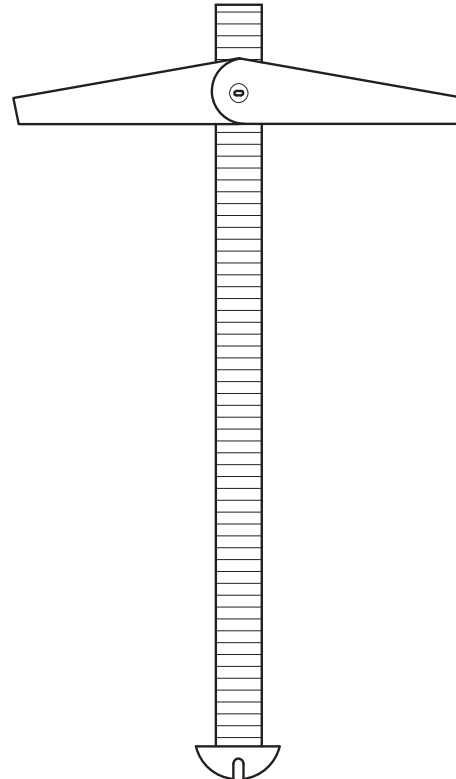

FIGURE 59 – TOGGLE BOLT

SIZE	DRILL SIZE	WEIGHT EACH
⅜ x 4	½	0.05
M5 x 102	M12	0.02
⅜ x 5	½	0.06
M5 x 127	M12	0.03
⅜ x 6	½	0.06
M5 x 153	M12	0.03
¼ x 4	⅝	0.08
M6 x 102	M16	0.04
¼ x 5	⅝	0.09
M6 x 127	M16	0.04
¼ x 6	⅝	0.10
M6 x 153	M1	0.05
⅝ x 4	⅞	0.19
M10 x 102	M20	0.09
⅝ x 5	⅞	0.22
M10 x 127	M20	0.10
⅝ x 6	⅞	0.24
M10 x 153	M20	0.11
½ x 4	1¼	0.32
M12 x 153	M30	0.15
½ x 5	1¼	0.35
M12 x 127	M30	0.16
½ x 6	1¼	0.40
M12 x 153	M30	0.18