

## COPPER CLEVIS HANGER

**Figure 100CT**

Designed to support non-insulated, stationary copper tubing lines from above, allowing for approximately 1" to 1½" of vertical adjustment after the tubing is in place. The lower nut (not furnished) adjusts the pipe line to the proper elevation, the top nut (not furnished) prevents loosening due to vibration, and must be tightened securely to assure proper hanger performance.

**Material:** Carbon Steel.

**Compliance:** Federal Specification A-A-1192A Type 1, MSS-SP-69 Type 1 and BSPSS-BS3974. Rated Loads are for up to 650° F (343° C).

**Finish:** Copper.

**Ordering:** Specify tubing size, and figure number. For Metric applications specify Figure M100CT.

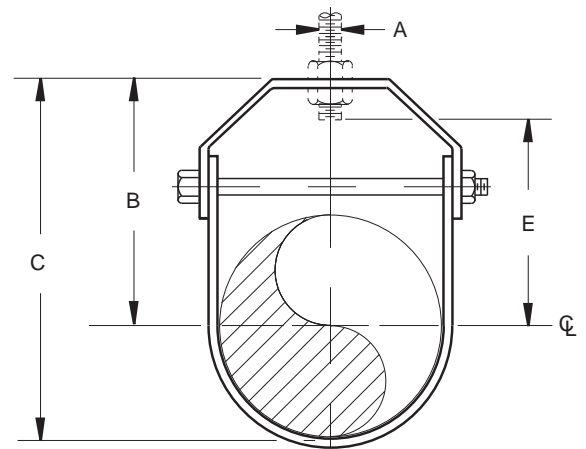

**FIGURE 100CT – COPPER CLEVIS HANGER**

TUBE SIZE	MAXIMUM LOAD	A	B	C	ROD TAKE OUT E	WEIGHT EACH
½	150	⅜	2⅞	3⅜	2½	0.16
15	667	M10	73	79	54	0.07
¾	250	⅜	2⅞	3	1⅞	0.16
20	1112	M10	67	76	48	0.07
1	250	⅜	2⅞	3⅜	1⅞	0.19
25	1112	M10	67	79	48	0.09
1¼	250	⅜	3⅞	3¾	2¾	0.22
32	1112	M10	79	95	60	0.10
1½	250	⅜	3⅞	4⅞	2⅞	0.29
40	1112	M10	86	105	67	0.13
2	250	⅜	3⅞	4⅞	2⅞	0.32
50	1112	M10	86	111	67	0.15
2½	350	½	3⅞	4⅞	2⅞	0.72
65	1557	M12	92	124	67	0.33
3	350	½	3⅞	5⅞	2⅞	0.82
80	1557	M12	98	137	73	0.37
3½	350	½	4⅞	5⅞	3⅞	0.91
90	1557	M12	105	149	79	0.41
4	350	½	4⅞	6¼	3⅞	1.07
100	1557	M12	114	159	89	0.49
5	900	⅝	5	7¾	3⅞	1.76
125	4004	M16	127	197	98	0.80
6	900	⅝	5¼	8⅞	4⅞	1.92
150	4004	M16	4	225	117	0.87

DIMENSIONS		TEMPERATURE	LOADS	WEIGHT
INCHES	FAHRENHEIT	POUNDS	POUNDS	
MILLIMETERS	CELSIUS	NEWTONS	KILOGRAMS	