

## PIPE ATTACHMENTS

### COPPER TUBING BAND HANGER

#### Figure 1A CT

Designed to support non-insulated, copper tubing lines from above. Install the same as a Figure 1A.

**Material:** Carbon Steel.

**Finish:** Copper.

**Compliance:** Federal Specification A-A-1192A Type 7, MSS-SP-69 Type 7.

**Ordering:** Specify tubing size, and figure number. For Metric applications specify Figure M1A CT. See Figure 1A for plain and electro-galvanized finishes. For PVC Coating refer to Figure 1A PVC.

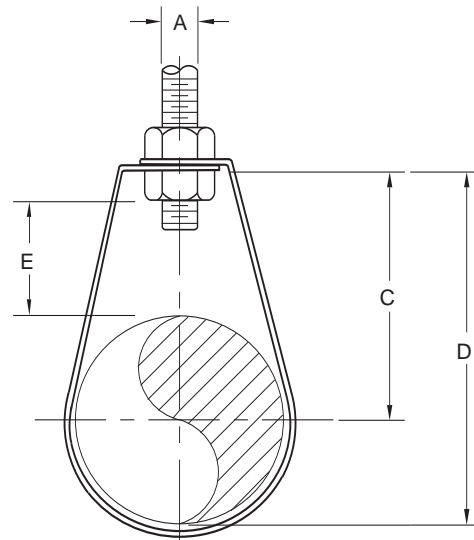

FIGURE 1A CT – COPPER TUBING BAND HANGER

TUBE SIZE	MAX LOAD	ROD SIZE A	C	D	ADJ. E	WEIGHT EACH
½	610	⅜	2⅞	2¾	1⅝	0.11
15	2714	M10	62	70	41	0.05
¾	610	⅜	2¾	2⅞	1⅝	0.11
20	2714	M10	70	68	33	0.05
1	610	⅜	2½	2⅞	1⅝	0.11
25	2714	M10	54	68	27	0.05
1¼	610	⅜	2½	2⅞	1⅝	0.12
32	2714	M10	54	71	24	0.05
1½	610	⅜	2⅝	3⅞	1⅝	0.14
40	2714	M10	60	87	27	0.06
2	610	⅜	2⅞	3⅞	1	0.16
50	2714	M10	65	92	25	0.07
2½	610	⅜	2⅞	4¼	1⅝	0.16
65	2714	M10	75	108	27	0.07
3	970	½	3¼	4⅞	1	0.38
80	4315	M12	83	122	25	0.17
3½	970	½	3⅞	5¼	1	0.42
90	4315	M12	87	133	25	0.19
4	1250	½	3¾	5⅞	1	0.45
100	5560	M12	95	151	25	0.20

DIMENSIONS	TEMPERATURE	LOADS	WEIGHT
INCHES	FAHRENHEIT	POUNDS	POUNDS
MILLIMETERS	CELSIUS	NEWTONS	KILOGRAMS