



Type-75 Butterfly Valve

Standard Features (Sizes 18" – 24")

- Standard model (18" - 24") has polypropylene body, disc and EPDM seat
- 403 stainless steel stem has full engagement over the entire length of the disc and is a non-wetted part totally isolated from the media
- Bubble-tight seating
- Only abrasion resistant, solid plastic disc and elastomeric liner are wetted parts

Options:

- Pneumatically and electrically actuated with accessories
- Lug style (stainless steel 304 and 316) as blocking and end of line applications
- Stems in 316 stainless steel, titanium, Hastelloy C[®] ‡
- 2" square nut on gear
- Stem extensions (single stem and two-piece stem)
- Locking device
- Chain operators
- Manual limit switch

Caution

- Never remove valve from pipeline under pressure.
- Always wear protective gloves and goggles.

FOR TROUBLESHOOTING, REFER TO PAGE 41.

Specifications

- Sizes:** 18" – 24"
- Models:** Wafer or Lug Style
- Operators:** Gear
- Bodies:** PP and PVDF
- Discs:** PP and PVDF
- Seats:** EPDM , FKM and Nitrile
- Seals:** Same as seating material
- Stems:** 403 and 316 stainless steel, Titanium, Hastelloy C[®] ‡

‡ Trademark of Cabot Corporation

Parts List (Sizes 18" – 24")

PARTS			
NO.	DESCRIPTION	PCS.	MATERIAL
1	Body	1	PP, PVDF
2	Disc	1	PP, PVDF
3	Seat	1	EPDM, FKM, Others
4	O-Ring (A)	2	EPDM, FKM, Others
5	O-Ring (B)	2	EPDM, FKM, Others
6	O-Ring (C)	1	EPDM, FKM, Others
7	Stem	1	Stainless Steel, (SUS 403)
7a	Key (A)	1	Carbon Steel (S45C)
7b	Snap Ring	1	Stainless Steel (SUS 304)
25	Gear Box	1	Cast Iron (FC250) Etc.
28	Bolt (C)	4	Stainless Steel (SUS 304)
207	Handle (C)	1	Cast Iron (FC250)
208	Handle Grip	1	Nylon, Etc.
209	Spring Pin	1	Stainless Steel (SUS 304)
216	Scale Plate	1	Stainless Steel (SUS 304)
1a	Ring	2	Chromized Steel (SS400) with Epoxy Powdercoat

Sample Specification

All solid thermoplastic butterfly valves (18" through 24") shall be of the lined body design and bubble-tight seal (meeting or exceeding Class VI as defined by American National Standard Institute) with only the liner and disc as wetted parts. The disc shall be of solid, abrasion resistant plastic, have double O-ring seals on top and bottom trunnions of the same material as the valve liner. Liner shall be molded and formed around the body, functioning as a gasket seal with convex ring design on each side of the valve for lower bolt tightening torque. Stem shall be of 403 stainless steel, non-wetted and have engagement over the full length of the disc. PP shall conform to ASTM D4101 Cell Classification PPO210B67272 and PVDF conforming to ASTM D3222 Cell Classification Type II. PP and PVDF bodies shall be rated to 75psi, size 18", and 50psi, sizes 20" and 24" at 70° F. Butterfly valves shall be wafer or lug style, as manufactured by Asahi/America, Inc.

Type-75

Butterfly Valves

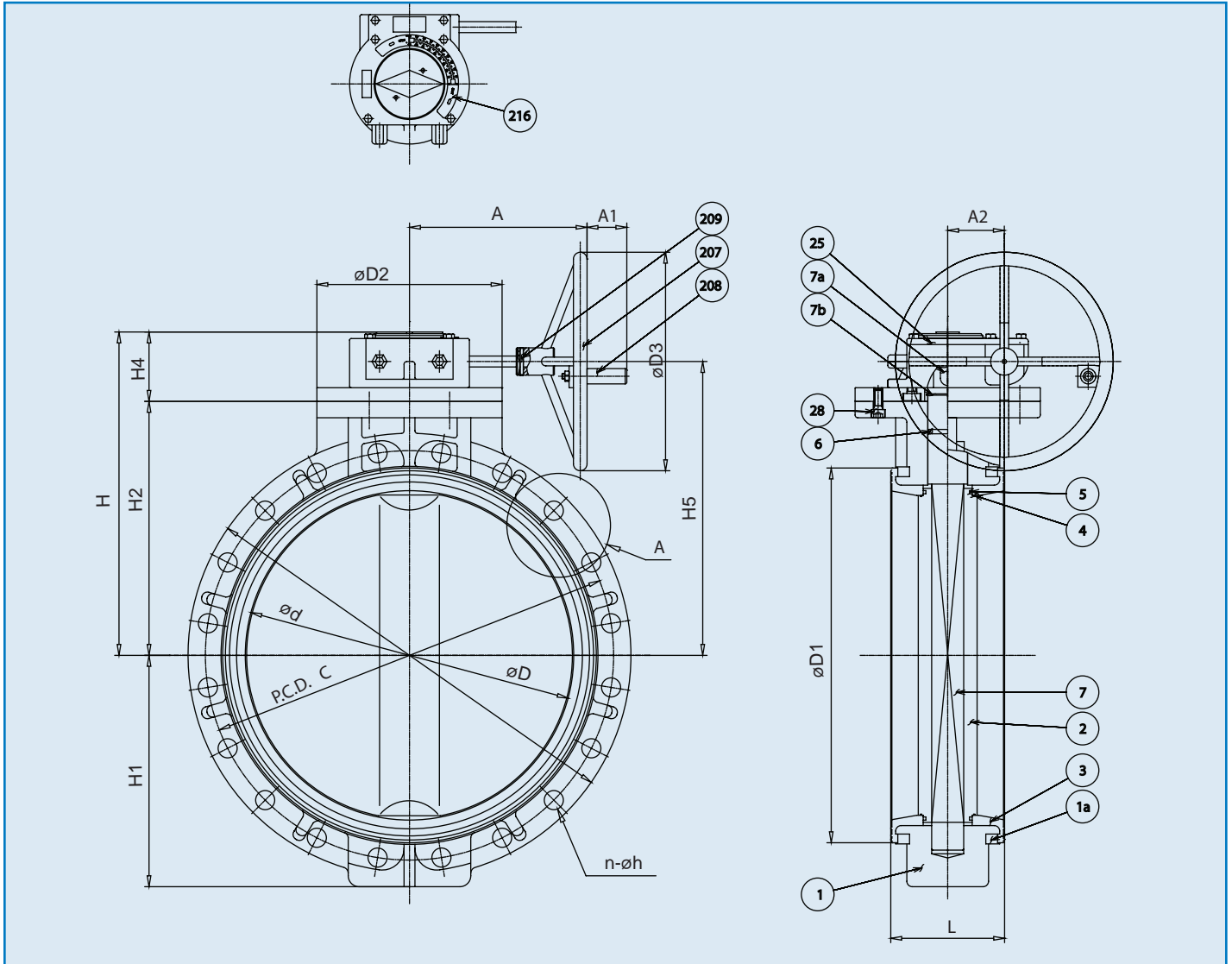

Dimensions (Sizes 18" - 24") (in.)

NOMINAL SIZE		ANSI CLASS 150					D													Gear Box Type
INCHES	mm	d	C	n	h	PP	PVDF	D1	D2	D3	L	H	H1	H2	H3	A	A1	A2		
18	450	17.80	22.75	16	1.25	24.92	24.80	20.67	13.39	15.75	7.05	12.40	12.40	14.57	5.00	12.83	2.97	4.11	AB1250N	
20	500	19.72	25.00	20	1.25	26.89	26.77	22.64	13.39	15.75	7.48	13.78	13.78	15.75	5.00	12.83	2.97	4.11		
24	600	23.74	29.50	20	1.38	31.22	31.10	27.01	13.39	15.75	8.23	16.69	16.69	18.31	5.00	12.83	2.97	4.11		

Cv Values

Wt. (lbs. / Vacuum Service / Pressure vs. Temperature (psi, water)*

NOMINAL SIZE		Cv (at various opening degrees)			NOMINAL SIZE		Gear	NOMINAL SIZE		VACUUM SERVICE (INCHES OF MERCURY)	BODY		PP		PVDF			
INCHES	mm	30°	60°	90°	INCHES	mm		INCHES	mm		DISC	PP	PVDF					
NOMINAL SIZE		-5° F		141° F	-5° F		141° F	176° F	211° F									
INCHES	mm	140° F	175° F	140° F	175° F	210° F	250° F											
18	450	1100	5020	10890	18	450	195	18	450	-19.69	75	45	75	45	30	15		
20	500	1448	6620	14060	20	500	232	20	500	-19.69	75	30	50	30	25	15		
24	600	2130	9180	18500	24	600	285	24	600	-19.69	75	30	50	30	25	15		
20-24	500-600										75	30	50	30	25	15		

* For lug style data consult factory.