

COPPER RISER CLAMP

Figure 126CT

The Figure 126CT is normally used for the support of uninsulated vertical tubing where no movement will occur. Please use our Figure 126 for carbon steel piping or Figure 126PVC for plastic coating requirements.

NOTE: This product is not designed to be supported with rods. Install using the maximum suggested torque values shown in the Technical Section of this catalog.

Material: Carbon Steel.

Compliance: Federal Specification A-A-1192A Type 8, MSS-SP-69 Type 8.

Finish: Copper.

Ordering: Specify tubing size and figure number. For Metric applications specify Figure M126CT.

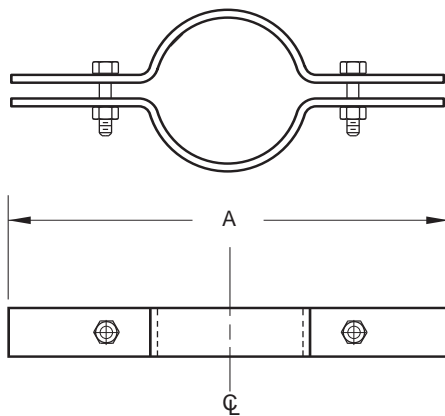

FIGURE 126CT – COPPER EXTENSION RISER CLAMP

TUBE SIZE	MAXIMUM LOAD	A	WEIGHT EACH
½	220	9⅝	0.70
15	979	233	0.32
¾	220	9⅝	0.74
20	979	233	0.34
1	220	9½	0.75
25	979	241	0.34
1¼	220	9¾	0.77
32	979	248	0.35
1½	220	10⅞	0.80
40	979	257	0.36
2	220	10½	0.84
50	979	6532	0.38
2½	390	11	1.60
65	1735	279	0.73
3	530	11⅞	1.80
80	2358	295	0.82
3½	530	12¾	1.95
90	2358	321	0.88
4	530	13¾	2.04
100	2358	333	0.93
5	810	14	3.50
125	3603	356	1.59
6	1570	15	5.25
150	6984	381	2.38

PVC COATED RISER CLAMP

Figure 126PVC

The Figure 126PVC is normally used for the support of uninsulated vertical piping where no movement will occur. PVC coating the contact surface prevents galvanic corrosion with the pipe. Please use our Figure 126 for carbon steel piping or Figure 126CT for copper tubing requirements.

NOTE: This product is not designed to be supported with rods. Install using the maximum suggested torque values shown in the Technical Section of this catalog.

Material: Carbon Steel.

Compliance: Federal Specification A-A-1192A Type 8, MSS-SP-69 Type 8. Operating temperature should not exceed 1400° F / 600° C.

Finish: Polyvinyl Chloride

Ordering: Specify pipe size and figure number. For Metric applications Specify Figure M126PVC. A completely PVC coated Figure 126 is available upon request. (Bolts and nuts will not be PVC coated.)

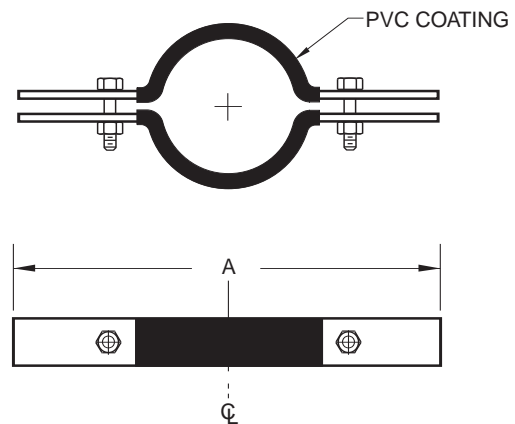

FIGURE 126PVC – PLASTIC COATED EXTENSION RISER CLAMP

PIPE SIZE	MAXIMUM LOAD	A	WEIGHT EACH
½	225	9⅞	1.30
15	1001	238	0.59
¾	225	9⅞	1.36
20	1001	238	0.62
1	225	9⅞	1.38
25	1001	244	0.63
1¼	225	10	1.95
32	1001	254	0.88
1½	225	10⅞	2.01
40	1001	264	0.91
2	225	10¾	2.17
50	1001	6694	0.98
2½	390	11¼	2.29
65	1735	286	1.04
3	530	12	2.50
80	2358	305	1.13
4	810	13½	3.42
100	3603	343	1.55

DIMENSIONS		TEMPERATURE	LOADS	WEIGHT
INCHES	FAHRENHEIT	POUNDS	POUNDS	
MILLIMETERS	CELSIUS	NEWTONS	KILOGRAMS	