

PIPE CLIP

Figure 72

The Figure 72 is designed to hold pipe flush to the mounting surface. A reinforcing bead through the center adds strength to the product. Our Figure 72CT is available for copper tubing lines.

Material: Carbon Steel.

Finish: Galvanized.

Ordering: Specify pipe size, and figure number.
For Metric applications Specify Figure M72.

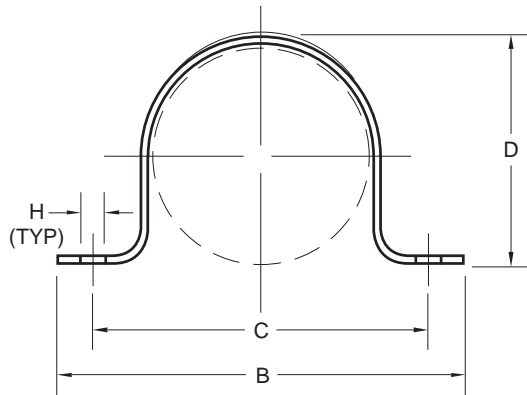

FIG. 72 – PIPE CLIP

PIPE SIZE	B	C	D	H	WGT. EACH
3/8	2 3/8	1 3/8	5/8	3/16	0.03
10	60	41	16	5	0.01
1/2	2 1/4	1 1/8	7/8	3/16	0.04
15	67	48	22	5	0.02
3/4	2 3/4	2	1	3/16	0.07
20	70	51	25	5	0.03
1	3 3/8	2 5/8	1 1/8	9/32	0.09
25	86	67	35	7	0.04
1 1/4	4 1/4	3 1/4	1 1/8	9/32	0.10
32	108	83	41	7	0.05
1 1/2	4 1/4	3 1/2	2	9/32	0.14
40	108	89	51	7	0.06
2	5	4 1/4	2 3/8	9/32	0.22
50	127	108	60	7	0.10
2 1/2	6 1/8	4 3/8	2 3/8	1 1/32	0.25
65	162	124	73	9	0.11
3	7 3/8	5 3/8	3 1/2	1 1/32	0.30
80	187	149	89	9	0.14
4	8 3/8	7 1/8	4 1/2	1 1/32	0.40
100	213	181	114	9	0.18
6	11 1/8	9 1/2	6 3/8	1 1/32	0.80
150	283	241	168	9	0.36

COPPER TUBING PIPE CLIP

Figure 72CT

The Figure 72CT is designed to hold copper tubing flush to the mounting surface. Our Figure 72 is available for steel piping lines.

Material: Carbon Steel.

Finish: Copper.

Ordering: Specify tubing size, and figure number.
For Metric applications Specify Figure M72CT.

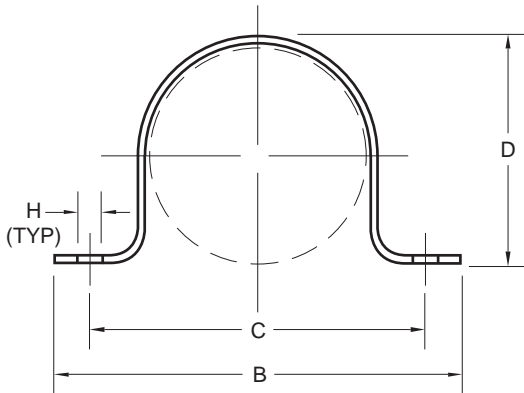

FIG. 72CT – COPPER TUBING PIPE CLIP

TUBING SIZE	B	C	D	H	WGT. EACH
3/8	2	1 3/8	1/2	3/16	0.019
10	51	35	13	5	0.009
1/2	2	1 3/8	5/8	3/16	0.020
15	51	35	16	5	0.009
3/4	2 1/4	1 1/4	7/8	3/16	0.022
20	60	44	22	5	0.010
1	3 1/2	2 1/4	1 1/8	3/16	0.025
25	89	70	29	5	0.011
1 1/4	3 3/4	3	1 1/8	3/16	0.031
32	95	76	35	5	0.014
1 1/2	3 3/4	3	1 3/8	7/16	0.063
40	98	76	41	11	0.029
2	4 1/2	3 3/8	2 3/8	7/16	0.075
50	114	92	54	11	0.034

DIMENSIONS		TEMPERATURE	LOADS	WEIGHT
INCHES	FAHRENHEIT	POUNDS	POUNDS	
MILLIMETERS	CELSIUS	NEWTONS	KILOGRAMS	