

Inductive Switches



Inductive Sensor	2 x NO Contacts
Operating Voltage	10 - 36 VDC
Current Rating (mA)	250
Reverse Polarity Protection	yes
Overload Protection	yes
Voltage Drop	< 2.5
Current Consumption (mA)	< 15 (24V)
Temperature (F)	13° F - 175° F
Protection	IP 67 (Type 6)
Materials	PBT/SS
Status Indicators	2 x Yellow LED
Connection	M12 Connection

Standard Features

- Low profile
- Engineered resin with stainless steel trim
- Two SPST N/O (PNP) hermetically sealed inductive switches
- M12 connection
- Visual position indication
- Low current consumption
- Temperature limit of 175° F

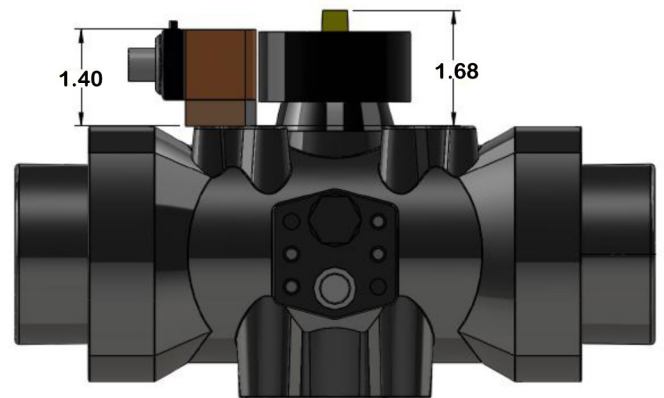

Options

- Patch cable (M12F x M12M)
 - Industrial - General purpose
 - Sanitary - Wash down
 - .3M, 6M, 1M, 2M , 5M lengths
 - Straight or angled
- Cord set (M12F x Flying Leads)
 - Industrial - General purpose
 - Sanitary - Wash down
 - 2M, 5M, 10M lengths
 - Straight or angled

Wiring

