

Series 10 Electric Actuator



Standard Features

- **Motor:** Reversing, squirrel cage induction motor, 115 VAC 50/60 Hz, single phase
- **Overload protection:** Integral thermal overload protection for motor windings with automatic reset
- **Gear train:** Permanently lubricated
- **Conduit:** Two 3/4" FNPT conduit entries to eliminate cross feed between control and power signals
- **Dec clutchable manual override:** Lockable de-clutching lever with handwheel
- **Limit switches:** Standard end of travel limit switches can be used for light indication (not to be used with PLC for position confirmation)
- **Auxiliary (Additional) limit switches:** Each electric actuator is provided as a standard with two SPDT auxiliary limit switches
- **Torque Switches:** two SPDT torque switches
- **Mechanical Stops:** Two +/- 10 percent mechanical travel stops
- **Enclosure:** Weatherproof rated Type 4X and 6
- **AWWA C542:** Conforms to AWWA C542
- **Self-Locking:** Self-locking worm gear design eliminates the need for a mechanical brake
- **Space Heater:** A space heater is provided as standard equipment
- **Output torque:** Series 10 electric actuators have an output torque range from 1,320 in./lbs. to 26,040 in./lbs.
- **Corrosion resistant mounting:** Mounting is with stainless steel bracket, stainless steel coupling, and stainless steel hardware
- Captivated SS socket cap cover screws

Specifications

Torque: 1,320-26,040 in./lbs.
Voltage: 120 VAC 1Ph 50/60 Hz
Amp Draw: 1.65 – 4.20
Conduit Entry: Two (2) 3/4" FNPT
Max Ambient Temperature: 150° F
Limit Switches: Four (4) single pole, double throw (4-SPDT) 10 amp rated
Torque Switches: Two (2) single pole, double throw (4-SPDT) 10 Amp rated
Cycle Time per 90°: 21– 93 seconds

Sample Specifications

All Series 10 electric actuators shall have a thermally protected, bidirectional (reversing type), squirrel cage induction motor with a permanently lubricated gear train. Actuator shall have self-locking worm gearing encompassed in a die cast aluminum housing anodized inside and outside, with an external polyester powder coat finish, rated Type 4X and 6. Each actuator shall have a lockable manual override, visual position indication, two auxiliary limit switches, two torque switches and a space heater, as supplied by Asahi/America, Inc.

Options

- Positioner: 4-20 mA or 0-10 VDC input
- 4-20 mA output transmitter
- Two-wire control
- Voltages: 230/1, 380/3, 460/3, 24 VDC
- ModBus
- ATEX enclosure
- Local remote station

Series 10 Electric Actuator

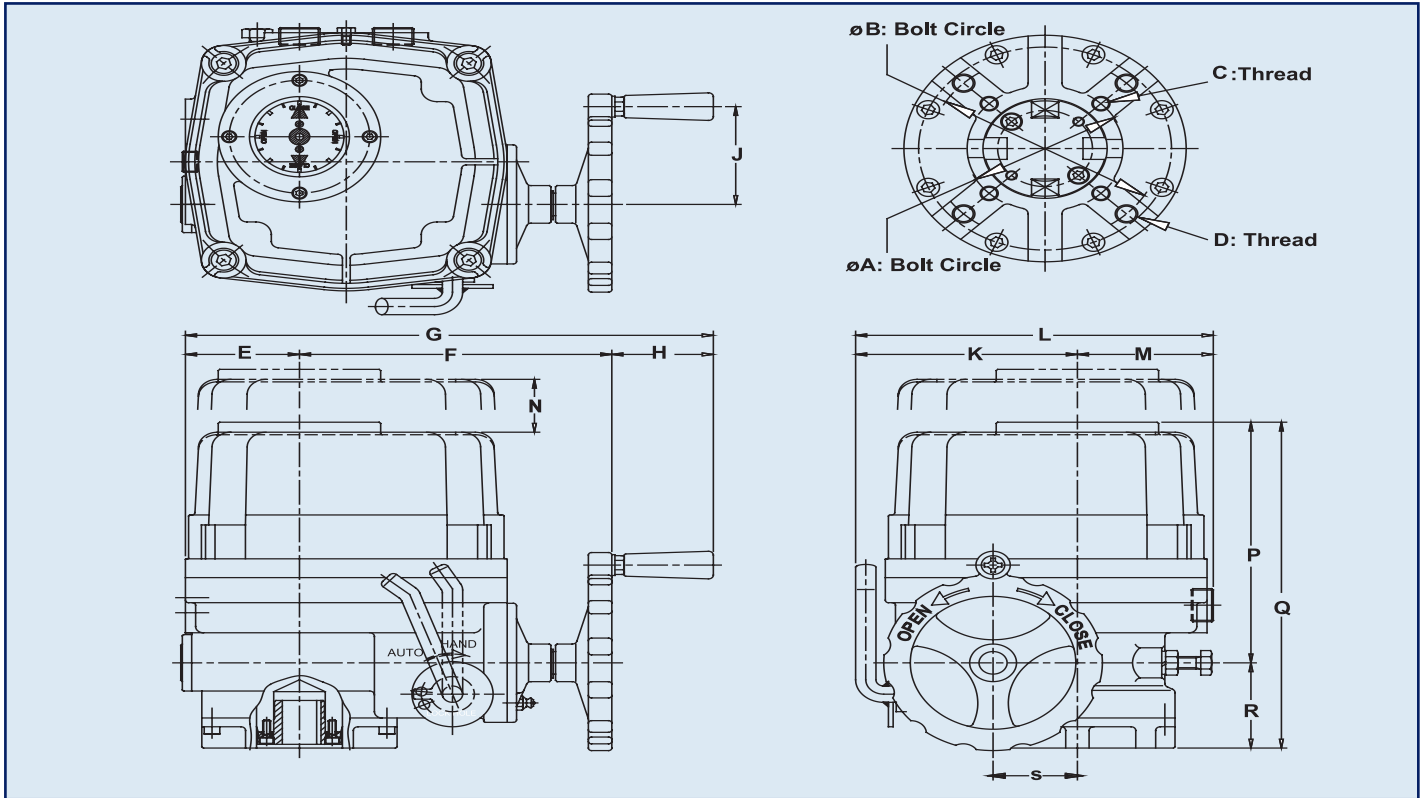

Dimensions (in.)

Model	A	B	C	D	E	F	G	H	J	K	L	M	N	P	Q	R	S
10-15	2.76	4.02	M8 x 12 DEEP	M10 x 15 DEEP	2.87	7.87	13.31	2.56	3.07	5.59	9.02	3.43	6.30	7.56	10.24	2.68	2.13
10-20	2.76	4.02	M8 x 12 DEEP	M10 x 15 DEEP	2.87	7.87	13.31	2.56	3.07	5.59	9.02	3.43	6.30	7.56	10.24	2.68	2.13
10-30	4.02	4.92	M10 x 15 DEEP	M12 x 18 DEEP	3.23	7.87	14.46	2.56	3.07	6.30	10.20	3.90	7.09	8.70	11.42	2.72	2.56
10-50	4.02	4.92	M10 x 15 DEEP	M12 x 18 DEEP	3.23	8.70	14.49	2.56	3.07	6.30	10.20	3.90	7.09	8.70	11.42	2.72	2.56
10-60	4.02	4.92	M10 x 15 DEEP	M12 x 18 DEEP	3.23	8.70	14.49	2.56	3.07	6.30	10.20	3.90	7.09	8.70	11.42	2.72	2.56
10-80	4.92	5.51	M12 x 18 DEEP	M16 x 25 DEEP	4.06	9.53	16.14	2.56	4.33	7.32	11.69	4.37	8.27	9.49	12.40	2.91	3.07
10-120	4.92	5.51	M12 x 18 DEEP	M16 x 25 DEEP	4.06	9.53	16.14	2.56	4.33	7.32	11.69	4.37	8.27	9.49	12.40	2.91	3.07
10-200	6.49	6.49	M20 x 30 DEEP	M20 x 30 DEEP	4.06	9.53	16.14	2.56	4.33	7.32	12.56	5.24	8.27	9.49	21.57	2.91	3.07
10-300	6.49	6.49	M20 x 30 DEEP	M20 x 30 DEEP	4.06	9.53	16.14	2.56	4.33	7.32	12.56	5.24	8.27	9.49	21.57	2.91	3.07

Engineering Data

Model	Torque (in./lbs.)	120/1 VAC		230/1 VAC		380/3 VAC		460/3 VAC		24 VDC		Cycle Time per 90 Degrees (Seconds)*	Weight
		Amp Draw	Duty Cycle	Amp Draw	Duty Cycle	Amp Draw	Duty Cycle	Amp Draw	Duty Cycle	Amp Draw	Duty Cycle		
10-15	1320	1.65	70	0.88	70	0.31	70	0.30	70	2.20	70	21	37
10-20	1740	1.67	70	0.89	70	0.31	70	0.30	70	2.50	70	21	37
10-30	2580	1.85	70	0.92	70	0.35	70	0.34	70	2.90	70	26	49
10-50	4320	3.60	70	1.55	70	0.59	70	0.58	70	N/A	N/A	26	51
10-60	5220	3.65	70	1.60	70	0.60	70	0.59	70	N/A	N/A	26	51
10-80	6960	4.10	70	2.15	70	0.85	70	0.79	70	N/A	N/A	31	64
10-120	10,440	4.20	70	2.35	70	0.87	70	0.81	70	N/A	N/A	31	64
10-200	17,400	4.10	70	2.15	70	0.85	70	0.79	70	N/A	N/A	93	166
10-300	26,040	4.20	70	2.35	70	0.87	70	0.81	70	N/A	N/A	93	166

*Cycle times are approximate