

Pneumatic Actuators with Solenoid

The solenoid valve used for our pneumatic actuators is a four-way, on/off, electrically controlled valve. An electrical signal to the solenoid's coil switches the compressed air supply to the appropriate actuator ports.

The solenoids are furnished with mufflers and speed controls. The muffler reduces the sound of the exhausting air, and the speed control determines the cycle time of the actuator. The speed controls are manually set needle valves, which can be adjusted. The cycle time can be slowed by restricting the flow of the exhausting air, thus maintaining back pressure on the opposite side of the pressured actuator cavity.

During the absence of electric power, the actuator can be cycled by operating the manual override on the solenoid, providing that supply air is still available

Upon electric failure, actuators will return to the de-energized position. This position can be either actuator position, depending upon how the plumbing is connected from the solenoid block to the air connection of the actuator.

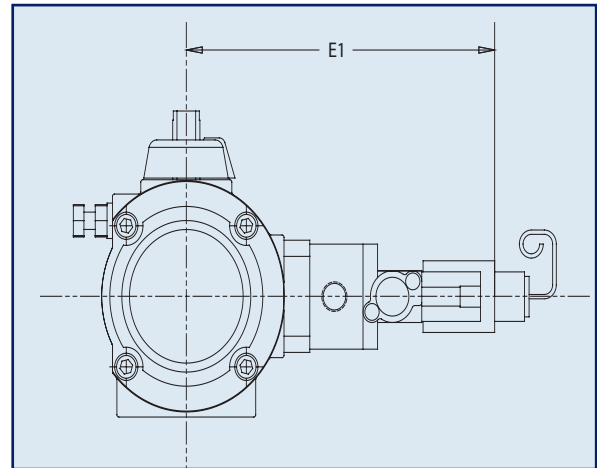
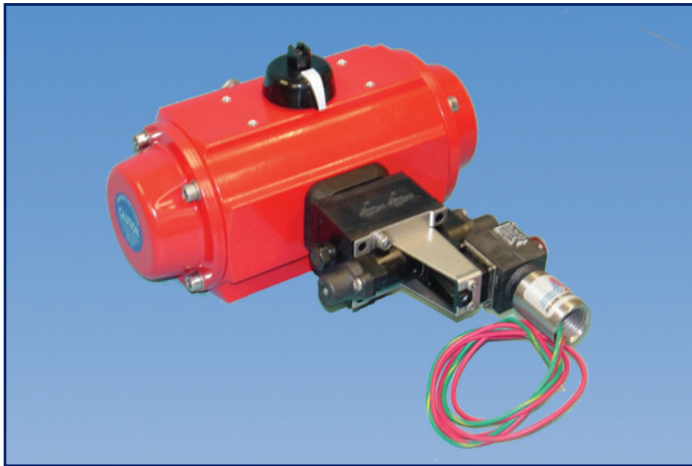

Standard Features

- Engineered resin body
- Type 4X 115 VAC coil
- NAMUR mount
- Stainless steel trim
- 1/4" FNPT air connection
- Combination three-way/four-way
- 1/2" FNPT stainless steel conduit entry
- Manual override
- Speed controls

Options

- Mufflers
- Combination Type 4X, 7 and 9 coil
- Voltages: 12 or 24 VAC
230 VAC
12 or 24 VDC

Dimensions (in.)

Model No.	E1
AP79P	5.77
B79PA	6.02
B579PA	6.38
C79PA	6.46
C579PA	6.65
D79PA	6.93
D579PA	7.36
E79P	8.00
F79P	9.01
G79P	9.61
M79P	12.80