

PIPE ATTACHMENTS

EXTENSION RING HANGER

Figure 81 (Rod Tapped – Electro-Galvanized)

Figure 81BRT (Rod Tapped – Plain Finish)

Figure 81SG (Two Bolt, Rod Tapped, Domestic – Electro-Galvanized)

This split ring hanger is designed for the support of non-insulated stationary pipe lines. Also available in a two screw design. The Figure 85 or 85CT Ceiling Plate is normally used with this product.

Material: Malleable Iron, except Figure 81SG and 81SCT which are carbon steel.

Finish: Plain, Electro-Galvanized. For Copper Coating please see Figure 81CT or Figure 81SCT.

Compliance: Federal Specification A-A-1192A Type 12, MSS-SP-69 Type 12.

Ordering: Specify pipe size and figure number. For Metric applications specify Figure M81, M81BRT, M81PT, M81SG or 81SCT.

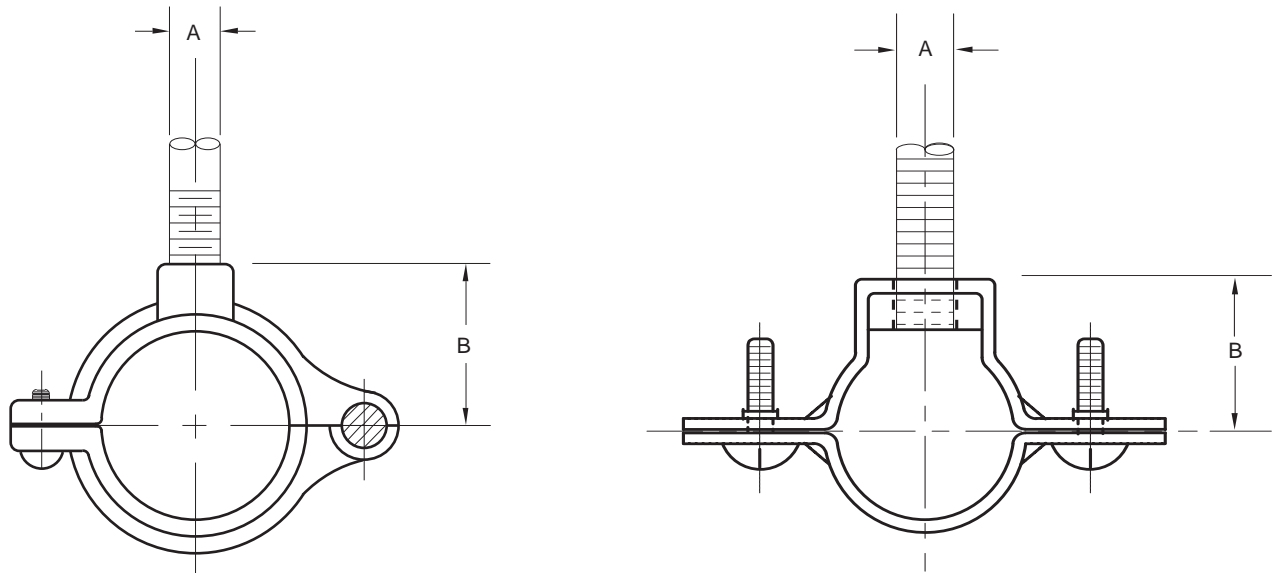

FIGURE 81 AND 81SG – EXTENSION HANGER RING

PIPE SIZE	MAX LOAD	PIPE SIZE A	ROD SIZE A	FIGURE 81	FIGURE 81SG	WEIGHT EACH	
				B	B	FIG. 81	FIG. 81SG
3/8	180	1/4	3/8	13/16		0.16	
10	801	8	M10	21		0.07	
1/2	180	1/4	3/8	7/8	23/32	0.17	0.10
15	801	8	M10	22	18	0.08	0.05
3/4	180	1/4	3/8	1	13/16	0.20	0.11
20	801	8	M10	25	21	0.09	0.05
1	180	1/4	3/8	1 1/8	31/32	0.21	0.12
25	801	8	M10	29	25	0.10	0.05
1 1/4	180	1/4	3/8	1 1/16	1 1/8	0.29	0.13
32	801	8	M10	33	29	0.13	0.06
1 1/2	180	1/4	3/8	1 1/16	1 1/4	0.31	0.14
40	801	8	M10	37	32	0.14	0.06
2	180	1/4	3/8	1 11/16	1 1/2	0.35	0.16
50	801	8	M10	43	38	0.16	0.07
2 1/2	480	1/2	1/2	2 1/8		0.57	
65	2135	15	M12	54		0.26	
3	480	1/2	1/2	2 1/16		0.72	
80	2135	15	M12	62		0.33	
4	480	1/2	1/2	3 1/8		1.16	
100	2135	15	M12	81		0.53	

DIMENSIONS		TEMPERATURE	LOADS	WEIGHT
INCHES	Fahrenheit	POUNDS	POUNDS	
MILLIMETERS	CELSIUS	NEWTONS	KILOGRAMS	