

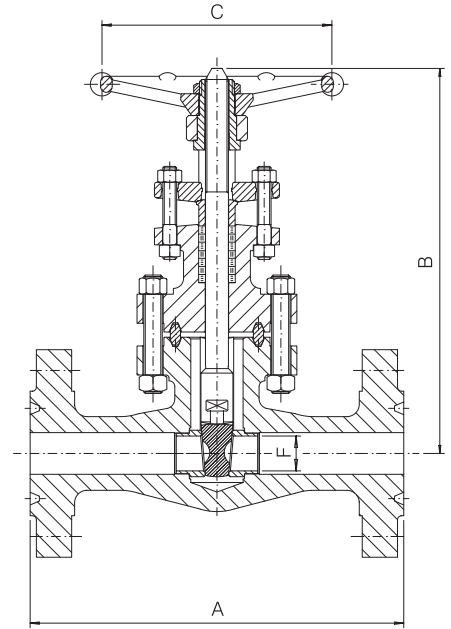

BONNEY FORGE

INTEGRAL FLANGED VALVES- GATE TYPE- BOLTED BONNET- FULL PORT

2500 LB.



Design construction:

- ASME B16.34 - BS 5352
- Full port type
- Testing according to API 598
- Marking MSS SP25
- Outside Screw and Yoke (OS&Y)
- Self aligning two piece packing gland
- Body Bonnet Gasket ring joint type
- Spiral wound type gasket on request
- Integral backseat
- Integral body flanges
- Face to face according to ASME B16.10
- Flanges according to ASME B16.5

Ratings:
 - carbon steel class 2500 6170 psig @ 100°F
 425 bar + 38°C

FULL PORT – FIG. 25RR 10						
SIZE	inch	1/2	3/4	1	1 1/2	2
	mm	15	20	25	40	50
A	inch	10.39	10.75	12.13	15.25	17.87
	mm	264	273	308	387,5	454
B open	inch	11.10	11.42	13.19	15.98	16.34
	mm	282	290	335	406	415
C	inch	5.43	5.43	6.77	9.21	12.60
	mm	138	138	172	234	320
F	inch	.45	.59	.76	1.10	1.50
	mm	11,5	15	19,5	28	38
Weight	lb.	35.5	38.75	63.75	132.25	143.25
	kg	16,2	17,6	29	60	65
PACKING		2B4	2B4	BH8	2B8	25B8
GASKET		R16	R16	R16	R19	R22