

PIPE ROLLS

ADJUSTABLE ROLL SUPPORT

Figure 142

The Figure 142 is designed for longitudinal movement of pipe where vertical adjustment is required. Although primarily used for support of the pipe, this component may also be placed over the pipe to act as a guide.

Material: Cast Iron Pipe Roll and Sockets with a Carbon Steel Axle. Do not exceed 450° F / 232° C at the contact point to the roll.

Compliance: A-A-1192A Type 42, MSS SP-69 Type 41.

Finish: Plain, Painted, Electro-Galv., Hot-Dip Galv.

For pipe with insulation and a pipe covering protection saddle the Figure 142 will have to be oversized to suit. Please see the Table below which shows the correct sizing for insulated pipe.

Ordering: Specify pipe size, figure number, and finish. For Metric applications specify Figure M142.

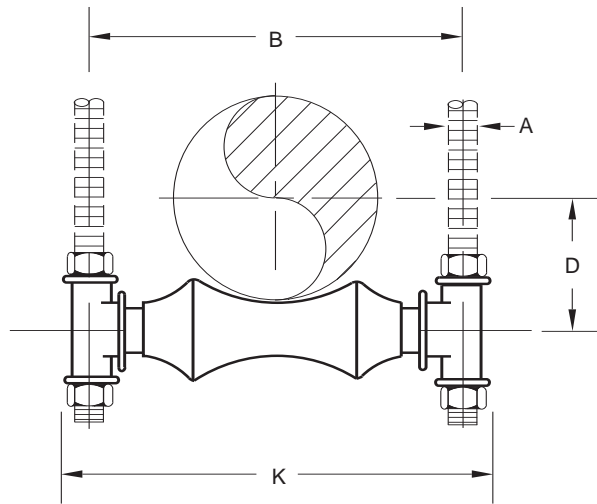

FIGURE 142 – ADJUSTABLE ROLL SUPPORT

PIPE SIZE	MAX LOAD	ROD SIZE A	B	D	K	WGT. EACH
1	600	3/8	3	1	4 1/2	0.45
25	2669	M10	76	25	105	0.20
1 1/2	600	3/8	3 3/8	1 1/4	4 1/2	0.48
32	2669	M10	86	32	114	0.22
1 1/2	600	3/8	3 5/8	1 3/8	4 3/4	0.51
40	2669	M10	92	35	121	0.23
2	600	3/8	4 1/8	1 1/2	5 1/4	0.57
50	2669	M10	105	41	133	0.26
2 1/2	600	1/2	5 1/2	2	7	1.48
65	2669	M12	140	51	178	0.67
3	700	1/2	6 1/8	2 1/4	7 3/8	1.48
80	3114	M12	156	57	194	0.67
4	700	3/8	7 1/8	2 3/8	8 3/8	1.78
100	3114	M16	181	73	219	0.81
5	700	3/8	8 3/8	3 1/2	9 3/8	2.42
125	3114	M16	213	89	251	1.10
6	1000	3/4	9 3/8	4	11 3/8	3.96
150	4448	M20	244	102	289	1.80
7	1200	3/4	10 3/8	4 3/8	12 3/8	5.99
175	5338	M20	273	121	318	2.72
8	1300	7/8	12	5 1/8	14	6.43
200	5783	M22	305	130	356	2.92
10	1700	7/8	14 3/8	6 1/4	16	8.45
250	7562	M22	359	159	406	3.83
12	2400	7/8	16 3/8	7 1/2	18	10.20
300	10676	M22	410	191	457	4.63
14	3100	1	17 3/8	8 3/8	20	20.90
350	13790	M24	451	213	508	9.48
16	3900	1	20 1/2	9 3/8	22 3/8	26.07
400	17349	M24	521	241	562	11.80
18	4200	1	22 3/8	10 1/2	24 3/8	36.59
450	18683	M24	562	267	619	16.60
20	4500	1 1/4	24 1/8	11 1/8	26 1/8	39.00
500	20018	M30	613	295	676	17.70
24	6100	1 1/2	28 3/8	14	32 3/8	66.90
600	27135	M36	733	356	816	30.30
30	7200	1 1/2	35 1/2	17 1/2	39 3/8	134.00
750	32028	M36	902	445	1013	60.80

DIMENSIONS		TEMPERATURE	LOADS	WEIGHT
INCHES	FAHRENHEIT	POUNDS	POUNDS	
MILLIMETERS	CELSIUS	NEWTONS	KILOGRAMS	