



GATE VALVES- EXTENDED BODY- STANDARD PORT- SOCKET WELDED- PLAIN END, SCREWED END & BUTT WELD END - WELDED & BOLTED BONNET

800 LB.

1500 LB.

Design construction:
 API 602 - ASME B16.34
 Testing according to API 598
 Marking MSS-SP-25
 Integral extended body
 Outside Screw and Yoke (OS&Y)
 Self aligning two piece packing gland
 Spiral-wound gasket
 Body-bonnet weld to ASME IX
 Integral backseat
 Socket Weld Ends to ASME B16.11
 Screwed Ends (NPT) to ASME B1.20.1
 Butt Welding Ends to ASME B16.25
Rating:
 -carbon steel class 800 1975 psig @ 100°F
 138 bar + 38°C
 -carbon steel class 1500 3705 psig @ 100°F
 255 bar + 38°C

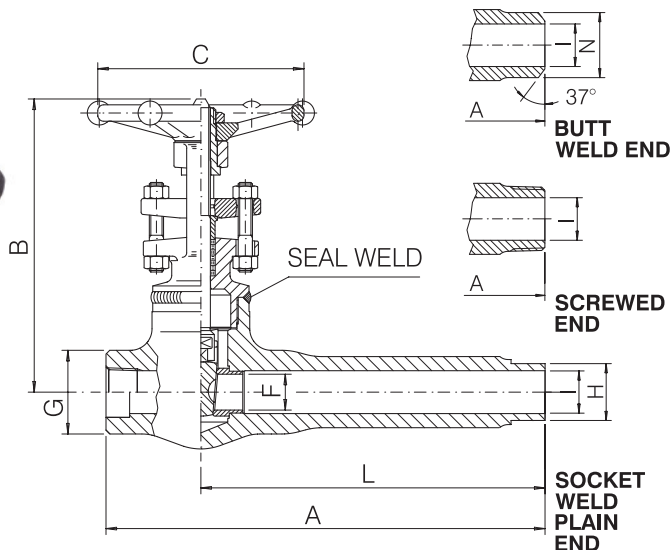
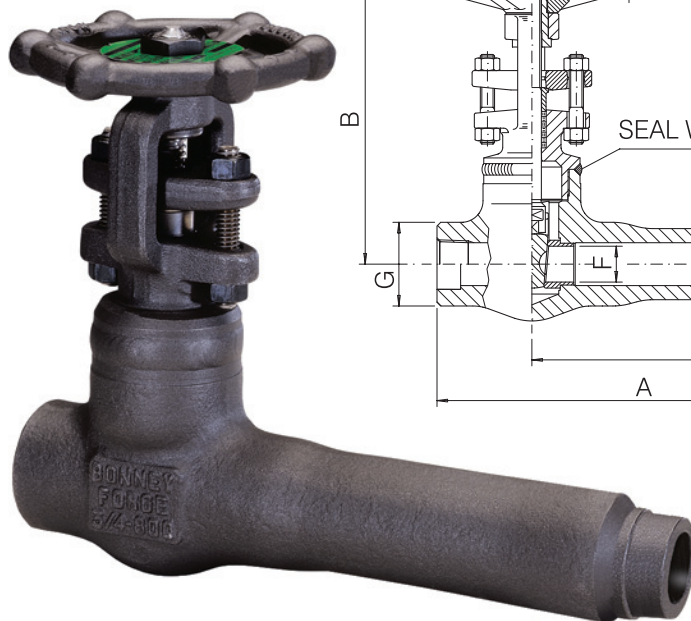

BOLTED BONNET – FIG. ML 10 / WELDED BONNET – FIG. MFL 10						
SIZE	inch mm	1/2 15	3/4 20	1 25	1 1/2 40	2 50
A	inch mm	5.57 141,5	5.77 146,5	6.53 166	7.50 190,5	8.50 216
B open	inch mm	5.98 152	6.14 156	7.72 196	10.08 256	11.42 290
C	inch mm	3.46 88	3.46 88	3.82 97	5.43 138	5.43 138
F	inch mm	.38 9,6	.55 14	.71 18	1.18 30	1.44 36,6
G	inch mm	1.26 32	1.50 38	1.89 48	2.52 64	3.07 78
H	inch mm	.84 21,3	1.05 26,7	1.31 33,4	1.90 48,3	2.37 60,3
I	inch mm	.51 13	.63 16	.83 21	1.34 34	1.65 42
L	inch mm	4.01 102	4.01 102	4.37 111	5 127	6.02 153
N	inch mm	.90 23	1.10 28	1.42 36	2.05 52	2.44 62
Weight Bolted B.	lb. kg	5.25 2,4	5.75 2,6	9.25 4,2	17.75 8,1	26 11,8
Weight Welded B.	lb. kg	3.75 1,7	4.5 2,1	7 3,2	15.75 7,2	22.75 10,3
PACKING		BH2	BH2	BH4	BH6	BY5
GASKET*		G2	G2	G3	G6	G7

BOLTED BONNET – FIG. 9ML 10 / WELDED BONNET – FIG. 9MFL 10					
SIZE	inch mm	1/2 15	3/4 20	1 25	1 1/2 40
A	inch mm	5.77 146,5	6.53 166	7.50 190,5	8.50 216
B open	inch mm	6.02 153	7.48 190	8.66 220	11.10 282
C	inch mm	3.46 88	3.82 97	5.43 138	5.43 138
F	inch mm	.38 9,6	.55 14	.71 18	1.18 30
G	inch mm	1.50 38	1.89 48	2.52 64	3.35 85
H	inch mm	.84 21,3	1.05 26,7	1.31 33,4	1.90 48,3
I	inch mm	.51 13	.63 16	.83 21	1.34 34
L	inch mm	4.02 102	4.37 111	5 127	6.02 153
N	inch mm	.90 23	1.10 28	1.42 36	2.05 52
Weight Bolted B.	lb. kg	5.75 2,6	10 4,6	20 9,1	28.5 13
Weight Welded B.	lb. kg	4.5 2,1	8.25 3,8	17.75 8,1	26.5 12
PACKING		BH3	BH5	BH6	2B5
GASKET*		G1	G2	G3	G5

Materials and trim specifications Page 91
 * Only for Bolted Bonnet type.

Male threaded ends in class 1500 lb. and NPS 1/2" in class 800 lb. not permitted by API 602