

CRYOGENIC VALVES- GATE TYPE- BOLTED BONNET- FULL PORT

1500 LB.

Design construction:

- ASME B16.34- BS 5352
- Full Port type
- Testing according to API 598
- Marking MSS SP25
- Outside Screw and Yoke (OS&Y)
- Self aligning two piece packing gland
- Body bonnet gasket ring joint type
- Spiral wound type gasket on request
- Integral backseat
- Integral body flanges
- Face to face according to ASME B16.10
- Flanges according to ASME B16.5
- Welded body bonnet joint also available
- Ratings: stainless steel A182- F316
- class 1500 3600 psig @ 100°F
- 248 bar + 38°C

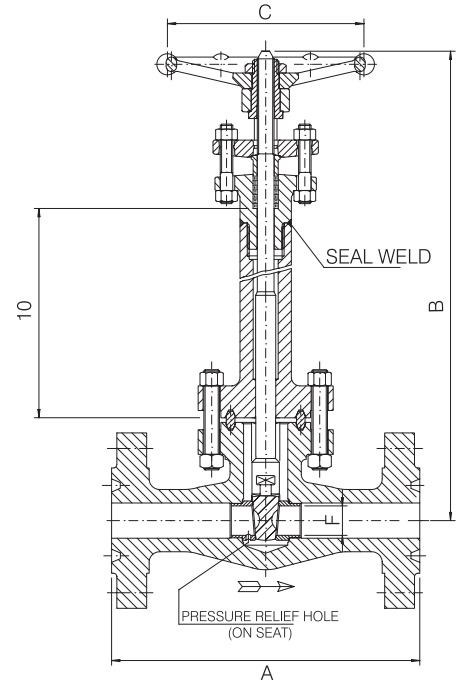

FULL PORT – FIG. 15CFR 10						
SIZE	inch mm	1/2 15	3/4 20	1 25	1 1/2 40	2 50
A	inch mm	8.50 216	9.01 229	10 254	12.01 305	14.62 371.5
B open	inch mm	17.91 455	19.29 490	19.68 500	22.64 575	24.80 630
C	inch mm	3.82 97	5.43 138	5.43 138	6.77 172	9.21 234
F	inch mm	.55 14	.71 18	.94 24	1.44 36.6	1.89 48
Weight	lb. kg	22.5 10.2	30.75 14	38.5 17.5	68.25 31	130 59
PACKING		BH5	BH6	2B4	BH8	4B8
GASKET		R12	R16	R16	R20	R22

Materials and trim specifications Page 91

TYPICAL DRAWING FOR GATE AND GLOBE WELDED BONNET CONSTRUCTION

