



Specifications

Sizes: Lever: 3" – 8"
Gear: 3" – 8"

Models: Wafer Style or Lug Style with 316SS lug inserts

Operators: Lever and Plasgear

Bodies: PVC

Discs: PVC, CPVC, PP and PVDF

Seats: EPDM, FKM, or Nitrile

Seals: Same as seating material

Stems: 316 stainless steel, Titanium, Hastelloy C[®] ‡

‡ Trademark of Cabot Corporation

Standard Features (Sizes 3" – 8")

- Direct replacement for metal valves conforming to ISO-5752 short face-to-face dimensions
- Standard model has PVC body with PP disc for superior chemical and corrosion resistance as well as elevated temperature capabilities
- Non-wetted 316 stainless steel stem has full engagement over the entire length of the disc and is totally isolated from the media
- Full seat design isolates the body and stem from the media and acts as mating flange gaskets
- Integral body stops in valve body to prevent overtightening of mating flanges
- Spherical disc design for improved Cv's and superior durability
- Integral locking lever handle with 21-position throttling plate
- Plasgear™ operator – Industry first composite enclosure gear operator
- Integral ISO-5211 top mounting pad for actuation mounting
- Polypropylene stem retainer to prevent stem removal

Options

- 316 stainless steel lug inserts for end of line service
- Pneumatic and electric actuators with accessories
- Alternate disc materials
(I) PVC
(II) CPVC
(III) PVDF
- Alternate stem materials
(I) Titanium
(II) Hastelloy C[®] ‡

Parts List (Lever: Sizes 3" – 8")

PARTS			
NO.	DESCRIPTION	PCS.	MATERIAL
1	Body	1	PVC
1e	Lug	-	Stainless Steel 316
2	Disc	1	PVC, PP, PVDF
3	Seat	1	EPDM, FKM, NBR
6	O-Ring (C)	1	EPDM, FKM, NBR
7	Stem	1	Stainless Steel 316
8	Stem Retainer	1	PP
16	Handle	1	PP
16a	Metal Insert in Handle	1	Stainless Steel 316L
17	Handle Lever	1	PPG
18	Pin	1	PPG
19	Spring	1	Stainless Steel 304
20	Washer (A)	1	Stainless Steel 304
21	Bolt (B)	1	Stainless Steel 304
22	Locking Plate	1	PPG
23	Screw (B)	4	Stainless Steel 304
24	Cap (A)	1	PP
156	Stabilization Ring	2	Stainless Steel (SCS13)
157	Screw (F)	4	Stainless Steel 304
158	Gasket	1	EPDM

*Supplied installed with lug style valves only.

Caution

- Never remove valve from pipeline under pressure.
- Always wear protective gloves and goggles.

(Options continued)

- 2" square operating nuts on valve stem or gear operator shaft
- Stem extensions for above ground or buried applications
- Chain operators
- Manual limit switches

Type-57LIS Lever Butterfly Valves

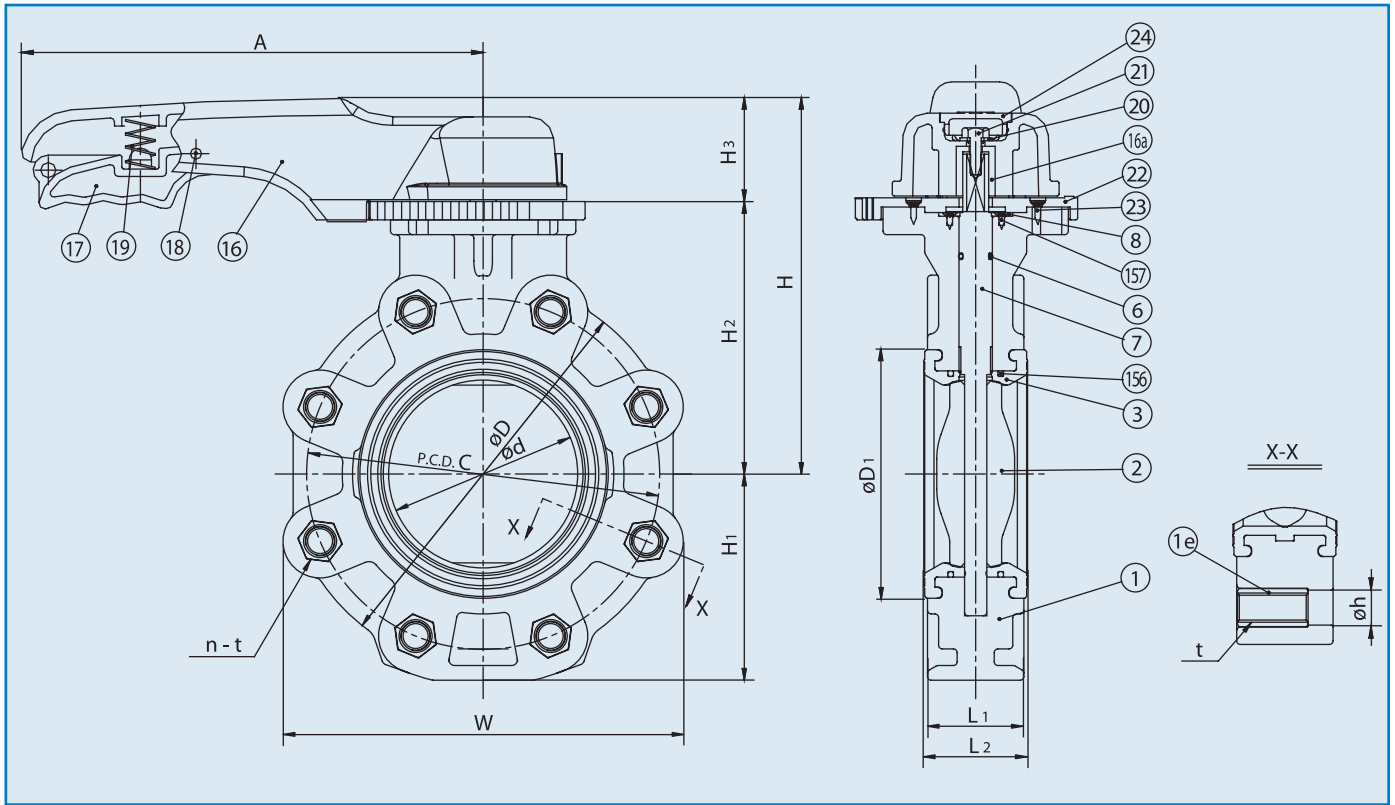

Dimensions (Lever: Sizes 3" – 8") (in.)

NOMINAL SIZE		ANSI CLASS 150																
		d	C	n	h	D	D1	L	L2	H	H1	H2	H3	A	W	T	t	
INCHES	mm																	
3	80	3.03	6.00	4	0.75	7.28	4.13	1.73	1.81	7.52	3.82	5.31	2.20	9.84	7.09	1.26	5/8-11 UNC	
4	100	4.02	7.50	8	0.75	8.27	5.28	2.05	2.20	8.11	4.41	5.91	2.20	9.84	8.50	1.52	5/8-11 UNC	
6	150	5.91	9.50	8	0.87	10.63	7.48	2.20	2.40	9.92	5.55	7.20	2.72	12.60	10.67	1.57	3/4-10 UNC	
8	200	7.68	11.75	8	0.87	12.60	9.53	2.36	2.66	11.14	6.61	8.43	2.72	15.75	12.76	1.57	3/4-10 UNC	

Press. vs. Temp.

BODY		PVC		
DISC		PP		
NOMINAL SIZE		30° F	121° F	141° F
INCHES	mm	120° F	140° F	175° F
3	80	150	70	30
4	100	150	45	30
6	150	150	45	30
8	200	150	40	20

Cv Values

NOMINAL SIZE		Cv (at various opening degrees)		
INCHES	mm	30°	60°	90°
3	80	18	183	300
4	100	28	287	470
6	150	66	671	1100
8	200	150	1525	2500

Vacuum Service Wt. (lbs.)

NOMINAL SIZE		VACUUM SERVICE (INCHES OF MERCURY)
INCHES	mm	
3	80	-29.92
4	100	-29.92
6	150	-29.92
8	200	-29.92

NOMINAL SIZE		LEVER OPERATED	GEAR OPERATED
INCHES	mm		
3	80	5	10
4	100	7	12
6	150	15	20
8	200	25	30

Type-57LIS – Gear Operated Butterfly Valve

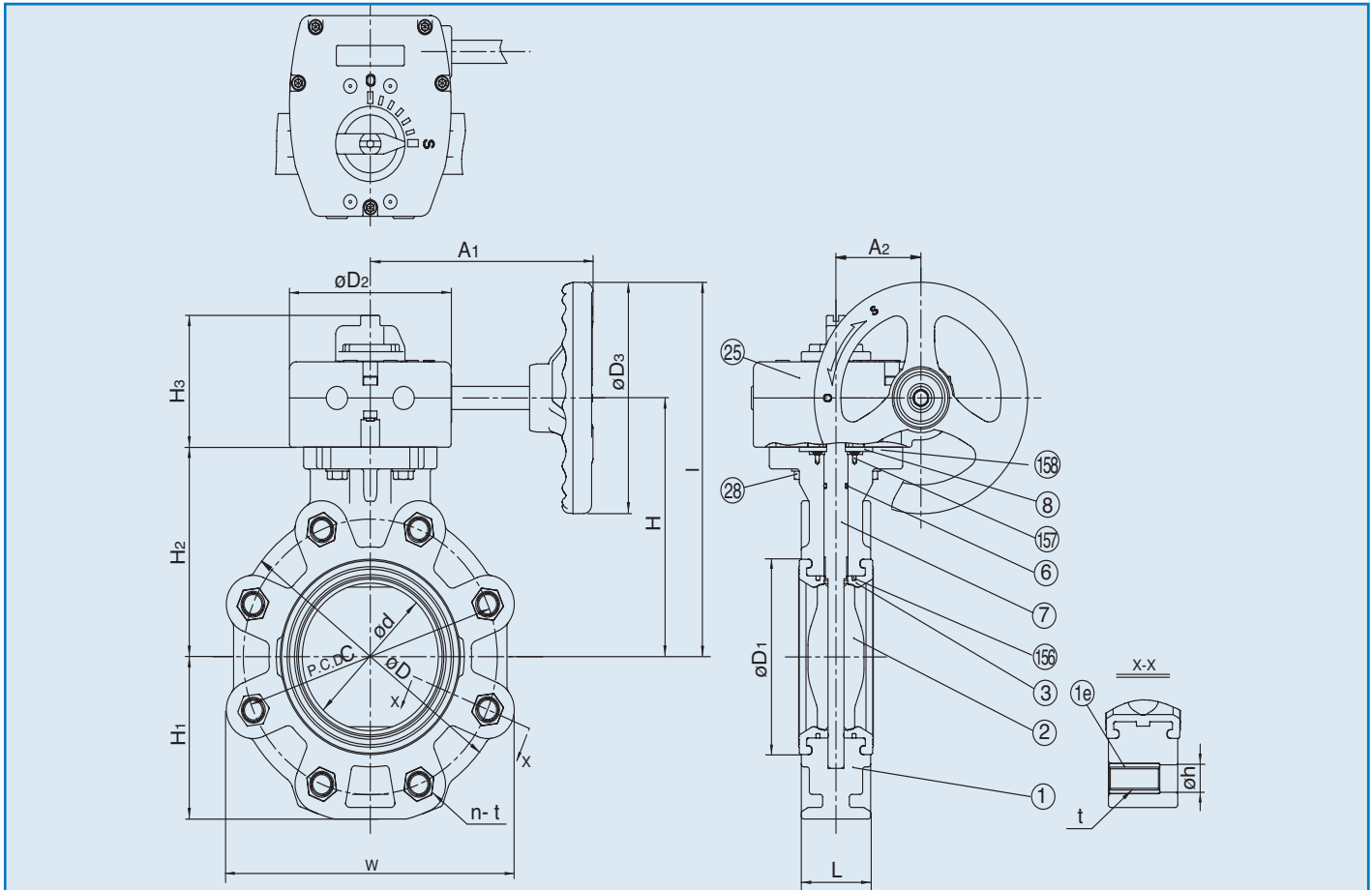

Dimensions (Gear: Sizes 3"-8") (in.)

NOMINAL SIZE	ANSI CLASS 150																					Wheel Cycles	
	INCHES	mm	d	C	n	h	D	D1	D2	D3	L1	L2	H	H1	H2	H3	L	A1	A2	W	T		t
3	80	3.03	6.00	4	0.75	7.28	4.13	4.80	6.30	1.73	1.81	6.50	3.82	5.12	3.62	9.65	6.57	2.52	7.09	1.26	5/8-11	UNC	9.5
4	100	4.02	7.50	8	0.75	8.27	5.28	4.80	6.30	2.05	2.20	7.09	4.41	5.71	3.62	10.24	6.57	2.52	8.50	1.52	5/8-11	UNC	9.5
6	150	5.91	9.50	8	0.87	10.63	7.48	4.80	6.30	2.20	2.40	8.27	5.55	6.89	3.62	11.42	6.57	2.52	10.67	1.57	3/4-10	UNC	9.5
8	200	7.68	11.75	8	0.87	12.60	9.53	4.80	6.30	2.36	2.66	9.49	6.61	8.11	3.62	12.64	6.57	2.52	12.76	1.57	3/4-10	UNC	9.5

Parts List (Gear: 3" – 8")

PARTS			
NO.	DESCRIPTION	PCS.	MATERIAL
1	Body	1	PVC
1e	Lug	-	Stainless Steel 304, 316
2	Disc	1	PVC, PP, PVDF
3	Seat	1	EPDM, FKM, NBR
6	O-Ring (C)	1	EPDM, FKM, NBR
7	Stem	1	Stainless Steel 316
8	Stem Retainer	1	PP
25	Gear Box	1	Plasgear™
28	Bolt (C)	4	Stainless Steel 304
156	Liner Stabilization Ring	2	Stainless Steel (SCS13)
157	Screw (F)	4	Stainless Steel 304
158	Gasket	1	EPDM

Sample Specification

All Type-57LIS butterfly valves shall be of solid thermoplastic lined body design with only the disc and seat as wetted parts. The face-to-face dimension shall be in accordance to ISO-5752 short face-to-face dimensions. All valves shall meet Class 6 bubble-tight shut-off standards. Operators shall be either molded PP lever handles with PPG trigger and 21-position throttle plate or Plasgear™ plastic enclosure gear operators. The lever handle shall feature a molded provision for padlocking. Valves shall feature spherical design discs for improved CV's and lower seating torque. Seats or liners shall be molded and formed around the valve body and provide a gasket face for mating flanges. The valve body shall include molded body stops to prevent mating flange overtightening. Valves shall be molded wafer style and accept 316 stainless steel factory installed lug inserts. Lug style valves shall be capable of having the downstream flange removed while maintaining full line pressure on the upstream side. Valve stems shall be 316 stainless steel and have full engagement over the entire length of the disc. Valves shall feature molded ISO-5211 top flange bolt patterns for actuation mounting. PVC shall conform to ASTM D1784 Cell Classification (CC) 12454-A, CPVC to ASTM D1784 CC 23567A, PP to ASTM D41101 CC 0210B67272, and PVDF to ASTM D3222-91A CC Type II. All Type 57LIS butterfly valves shall be rated to 150psi at 70° F and be wafer or lug style, as manufactured by Asahi/America, Inc.

* Supplied installed with Lug Style Valves only