



Specifications
 Size: 1/2" to 2"
 Body Material: PVC
 Bonnet Material: PVC
 Diaphragm: PTFE (Stock), EPDM (Special Order)
 Connections: IPS Socket, Female NPT, Flanged
 (All True Union)
 Operation: Air-to-Spring Closed, Air-to-Air
 Pilot Port: 1/8" FNPT

Dymatrix™

Standard Features (Sizes 1/2" – 2")

- Compact design for tight installations
- Robust design for high cycle life
- Ideal for OEM equipment and skids
- Highly configurable option

Options

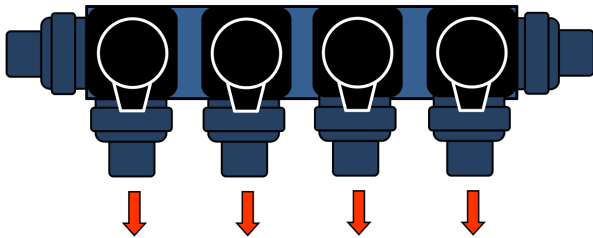

Manifolds



Travel Stop

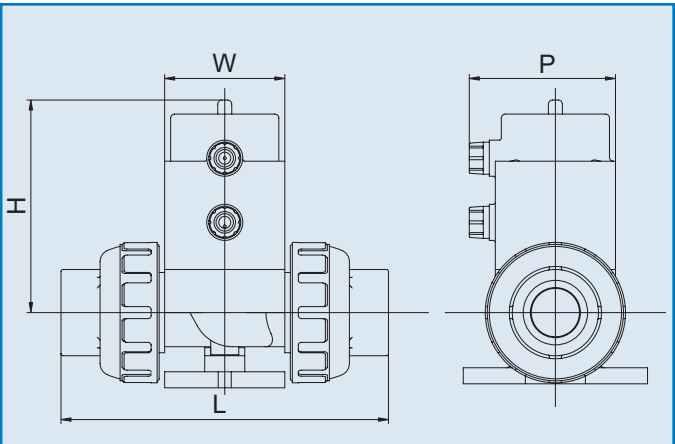

Dimensions (in.)

Size	Flanged	Threaded	Socket	H	W	P
	L	L	L			
1/2	6.22	4.61	4.65	3.11	1.97	2.48
3/4	7.52	5.47	5.43	4.25	2.36	2.87
1	8.09	5.87	5.89	4.29	2.36	2.87
1-1/2	10.39	8.46	8.50	6.36	3.74	4.23
2	11.69	10.24	10.24	7.42	4.53	5.04

