

*Detex Works Here.*



## Healthcare

Life Safety and Security Door Hardware

Integrated Door Security Systems

Safety, Security and Risk Management

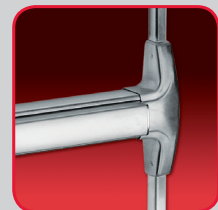

Where Trust is Built™  
**DETEX**®  
Life Safety, Security and Security Assurance

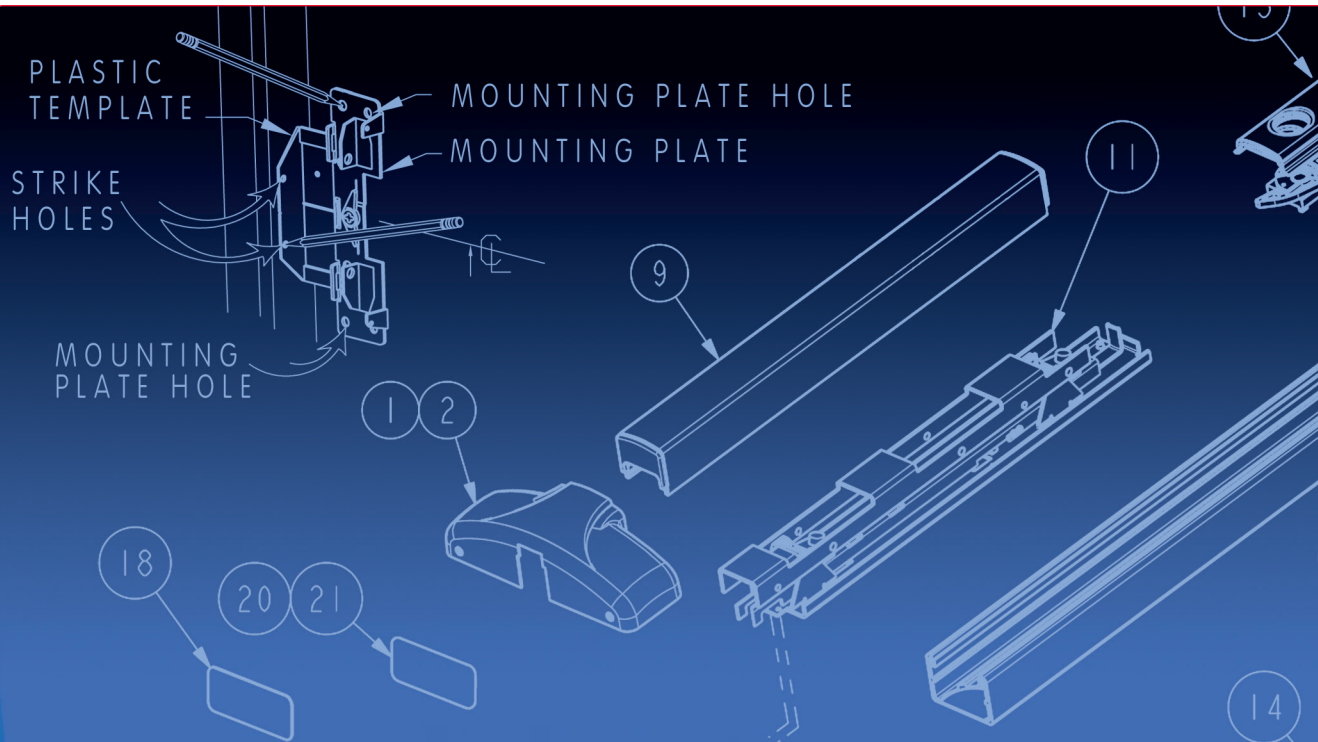

## Detex designs for healthcare

Today, the healthcare industry has changing needs for life safety and security hardware. Detex is meeting the challenge: simplifying what is complicated, engineering new solutions for applications that are only now emerging.



INCLUDED IN  
HARDWARE KIT

Hardware uniquely suited to high-use,  
high-abuse healthcare areas

With products that meet the stringent requirements of hospitals, assisted living residences, birthing centers, physicians office buildings, pharmacies and other healthcare facilities, Detex has developed a reputation as a primary resource for the industry. Our hardware is engineered for dependability in critical situations, and it is regarded as the most reliable for a variety of applications, both indoors and out.

### Where trust is built

Chosen by architects, locksmiths, maintenance supervisors, contractors and building managers who need hardware that has the options they want, our hardware is easy to install and requires minimum maintenance. Industry professionals know from experience that Detex products will always work when called upon.



# Advanced hardware for healthcare applications

Systems and solutions designed to work together

All healthcare businesses share a major concern: protecting patients and employees. At hospitals and assisted living facilities, rehabilitation clinics and medical offices, nursing care centers and pharmacies, access and exit control has become critical. Movement must be monitored at interior doors, courtyard gates and side doors, allowing them to open in an emergency or — equally important — to prevent unauthorized outsiders from entering. That's where Detex comes in, with the most advanced life safety and security hardware for internal and external controlled entrance and exit.

## Integratable hardware

Certain healthcare applications require a combination of components, and Detex offers a range of hardware designed specifically for healthcare uses. In addition, we offer complete systems made up of hardware that efficiently and effectively meets your more complex application requirements. When you select the exact components that suit your application, you know that they will integrate properly with each other and function well as a system.

We also offer preconfigured Detex EasyKits® to give you the advantage of simple installation with any hardware you already have in place, such as tailgate detection devices, door prop alarms, camera setups, or wander-guarding equipment for nurse stations.

## Advantex® quality

To withstand the rigors of constant jarring by staff or equipment being pushed through, Detex designs healthcare hardware with premium-grade Advantex quality. It's engineered with durable finishes and sleek, no-hook profiles that prevent catching on purses, uniforms or medical equipment. Advantex quality is an investment that pays off with lower maintenance and longer service.

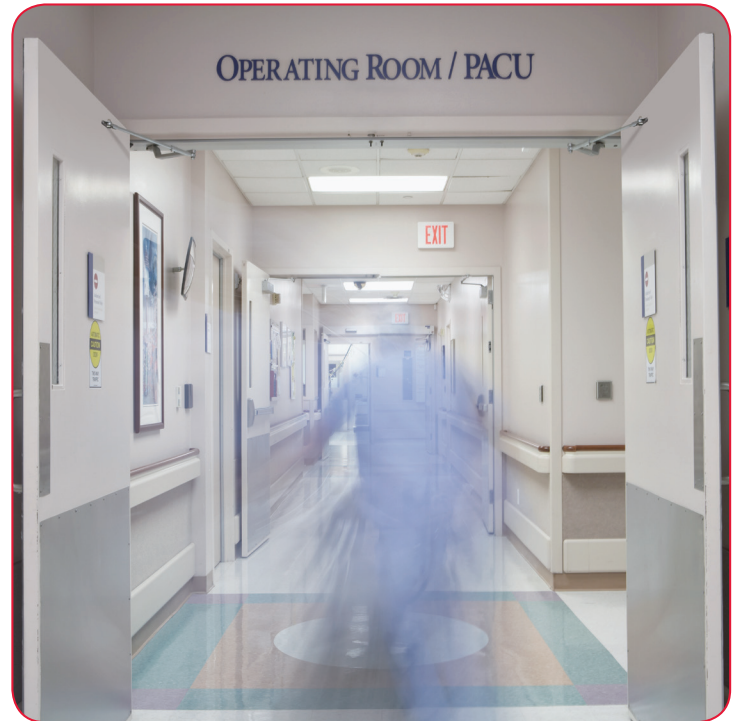

Hands-free access for medical buildings.

## Automatic Swing Door System

From exterior and interior doors for the public, to interior doors restricted to staff, the Detex Automatic Swing Door System allows reliable hands-free entry/exit.

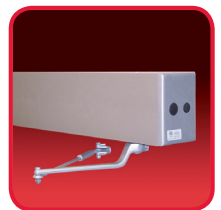

Detex is the only manufacturer to integrate all automatic door and associated controller components, pre-wired in one unit that's easy to install, wire and service.



- AO19 AOD features a heavy-duty, direct-drive motor that's a workhorse on the job, operating light or heavy doors in low energy applications.
- Advantex Panic Hardware provides delayed egress with latch retraction. Alarm sounds during 15-second delay to alert staff to unauthorized entry before door opens. Includes electrified options.
- Access Control permits authorized immediate entry using keypad or card readers.
- Wall Button automatically opens interior and exterior doors for the general public. Security locking and panic unlocking after hours.





Reliable protection for off-limits departments.

#### Restricted Access System

Detex puts dependable panic hardware in restricted secure areas—at birthing center entrances, pharmacies, surgical suites, and any other area where unauthorized entry must be controlled, and authorized entry must be easy, quick and reliable.

Any or all of these components can be combined as a Restricted Access System that meets specific enhanced levels of security in the most sensitive areas of your facility:

- Advantex Panic Hardware provides delayed egress with latch retraction. Alarm sounds during 15-second delay to alert staff to unauthorized entry before door opens.
- Access Control permits authorized immediate entry using keypad or card reader. Includes panic unlocking.
- Single Person Entry (Tailgate detection) allows only one authorized entry at a time.
- Door Prop Alarms signal that an entrance is standing open.



Panic hardware for courtyards, gardens, and other outdoor areas.

#### Outdoor Area System

Exclusive to Detex, our weatherized panic hardware is an ideal solution for protection of residents, patients, staff or visitors who spend time outside in secured areas.

Because our weatherized Outdoor Area System hardware is Advantex quality, it is extra durable in all weather environments and is available in a variety of finishes. Whether your application is simple or complex, custom or standard, you can order EasyKits that contain all parts to make installation easier.

- Weatherized Panic Device with delayed unlocking sounds alarm and notifies staff of exit attempt. Allows panic unlocking after 15-second delay.
- Access Control allows entry from outside with keypad or card reader.
- DX Bolts further secure outside area by preventing hinge cutting.
- Weatherized Door Prop Alarm warns that door or gate is being held open. Battery-powered or wired.





Staff only.

#### Tailgate Detection System

If your healthcare operation has certain entry doors where access must be limited to one identified entrant at a time, you want to be sure that no one is able to slip through undetected, behind an employee, during or after hours.

You may also need to protect departments inside your facility. Birthing centers, research labs or patient record offices must be off-limits to those who have no business there, and this hardware prevents unauthorized tailgate entry. The Tailgate Detection System is compatible with most access control technologies, is easy to retrofit, and has an integrated door prop alarm for extra security.

- AT5200 Tailgate Detection System employs infrared sensor beams to detect piggybackers, signaling a remote alarm, camera or security.
- Access Control EasyKit provides the components you need and are easy to install.
- Door Prop Alarms alert you to a door that has been deliberately propped open to permit unauthorized entry.



Centralized control in facility emergencies.

#### Lockdown System

Locking down external doors quickly is essential when threatening situations arise. Manual lockdown can take thirty to forty-five minutes or more, but with our Lockdown System it happens with the push of a button in the administrative offices, saving critical minutes. Making sure that unauthorized people don't gain entry, controlling access within the building, and allowing easy exit in an emergency can all be accomplished rapidly with centralized control.

- Lockdown System Components include durable Advantex panic hardware with electric latch retraction or electric dogging, remote control switches (central or multiple) for immediate lockdown, and power supplies.
- Auxiliary Security Equipment includes door prop alarms to alert staff of open exit doors, vandal-resistant breakaway trims, door position switches, and the ProxiPen proximity-based system for guard tour verification.
- Lockdown EasyKits include components for easy installation in your facility.



# Making rounds with ProxiPen

A high-tech tool for reliable reads at guard tour stations

Whether your healthcare facility is a single large building or a multi-building campus, the GCS® ProxiPen will help your operations. An innovative data collection and auto-ID system, the ProxiPen uses advanced proximity technology to autosense and read RFID tags. Wherever their location, the tags give visual and audible indications to confirm the information has been read when the ProxiPen comes within range.

Important for security checks, the ProxiPen is also used for mandatory checking, daily inspections and preventive maintenance, helping to lower liability and insurance costs.

Always working, whatever the weather  
Indoors or outdoors, the ProxiPen doesn't have to touch the tag, which can be concealed behind wallboard, plaster, paneling, mirrors or any other nonmetallic surface — a real plus in applications where aesthetics or vandalism are considerations. Outside tags are unaffected by water, ice or snow, so readings can be taken in any weather. The ProxiPen's tough, waterproof polycarbonate housing is compact, lightweight, and easy to handle.

Designed for efficiency

- ProxiPen delivers 50,000 data readings from one AA battery, which is user-changeable without tools or loss of data (preserved in non-volatile memory). Its high-memory capacity allows 4,063 readings, so it can be used in the field without the need for frequent downloading. Anti-tampering features discourage unauthorized battery removal.
- ProxiPen Kits include everything you need for quick set-up of a complete guard tour system, from tags and tag readers to TopGuard Patrol Software.
- TopGuard Patrol Software makes it simple to manage tours, download and evaluate collected data and prepare reports. An optional TopGuard Patrol Plus version provides extended capacity, more reporting options and other high-utility features.



TopGuard Patrol - Report	
Summary report	
All tours	
11/1/2012 12:00:00 AM ... 11/14/2	
Date	Time
DAU: ProxiPen 2001#00000168	
Downloaded 11/2/2012 08:33	
11/1/2012	23:01
(1) Offices 11/1/2012	23:02 [Pers
11/1/2012	23:02
11/1/2012	23:05

## More options at every entrance and exit

Only Detex offers you system options to fit your specific needs, from basic to more advanced. All of our hardware systems are field-proven to integrate and work, without compromise.

Indoors, outdoors, back and side doors, Detex has the right hardware for the life safety and security requirements that protect your employees and patients. From pharmacy doors to birthing centers, architectural doors to delivery doors, tailgate detection entrances to delayed egress side doors, every healthcare facility application is covered in our inventory.

- 1** Maximum Security System
- 2** Restricted Access System
- 3** Receiving Door System
- 4** Tailgate Detection System
- 5** Trash Removal Door System
- 6** Weatherized Outdoor Area System
- 7** Security Swing Door System
- 8** Lockdown System
- 9** Fire-rated System
- 10** Emergency Exit System
- 11** Windstorm Rated System
- 12** Access Control System
- 13** Employee Entrance System
- 14** Entry/ADA Swing Door System
- 15** Guard Tour

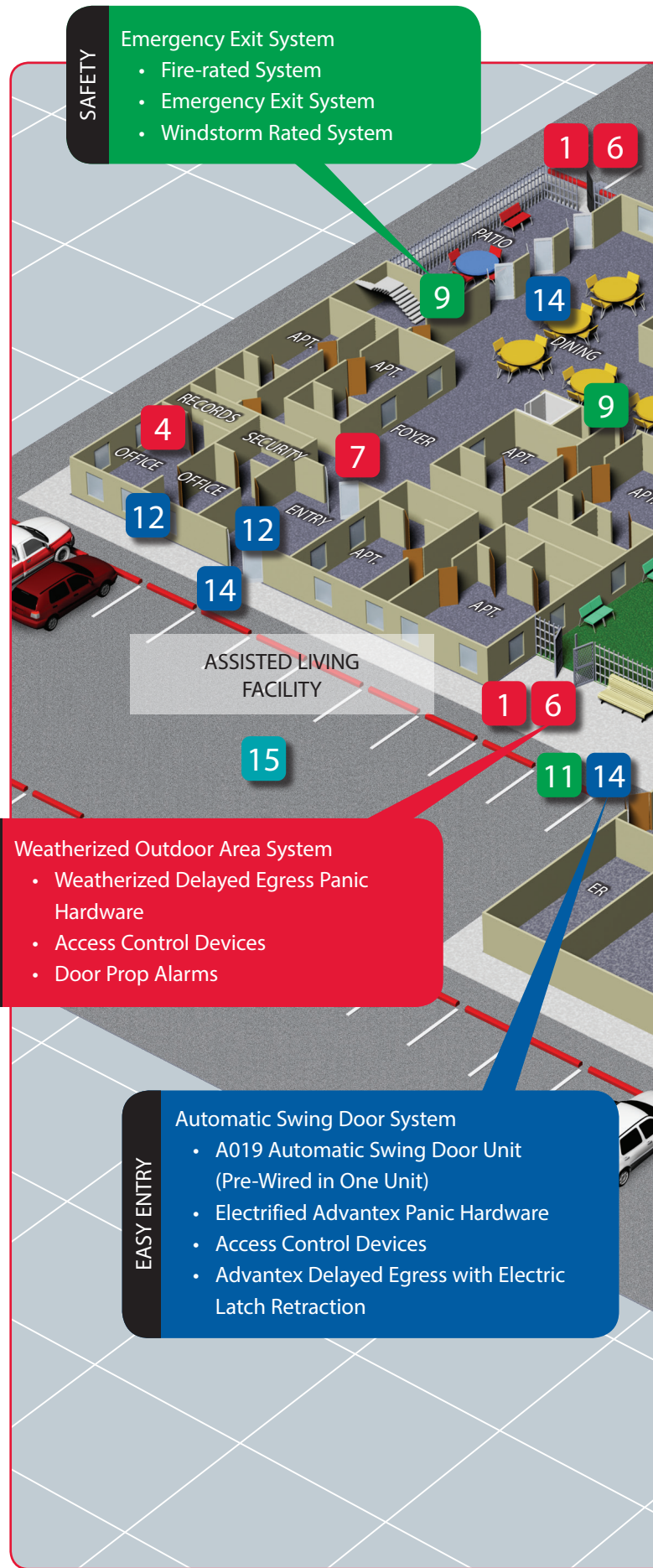



SECURITY

**Lockdown System**

- Advantex Hardware with Electrified Latch Retraction, Dogging
- Remote Control Switches
- Auxiliary Security Equipment

ACCESS CONTROL

**Security Swing Door System**

- A019 Automatic Swing Door Unit (Pre-Wired in One Unit)
- Electrified Advantex Panic Hardware
- Access Control Devices
- Advantex Delayed Egress with Electric Latch Retraction

**Restricted Access System**

- Advantex Alarmed Panic Hardware
- Access Control Devices
- Tailgate Detection
- Door Prop Alarms
- Advantex Delayed Egress with Electric Latch Retraction

**Tailgate Detection System**

- AT5200 Tailgate Detection
- Access Control EasyKit
- Door Prop Alarms

**GUARD TOUR**

**ProxiPen Readers**

- RFID Data Collection
- Proximity Technology
- TopGuard Patrol Software
- Maintenance Inspections

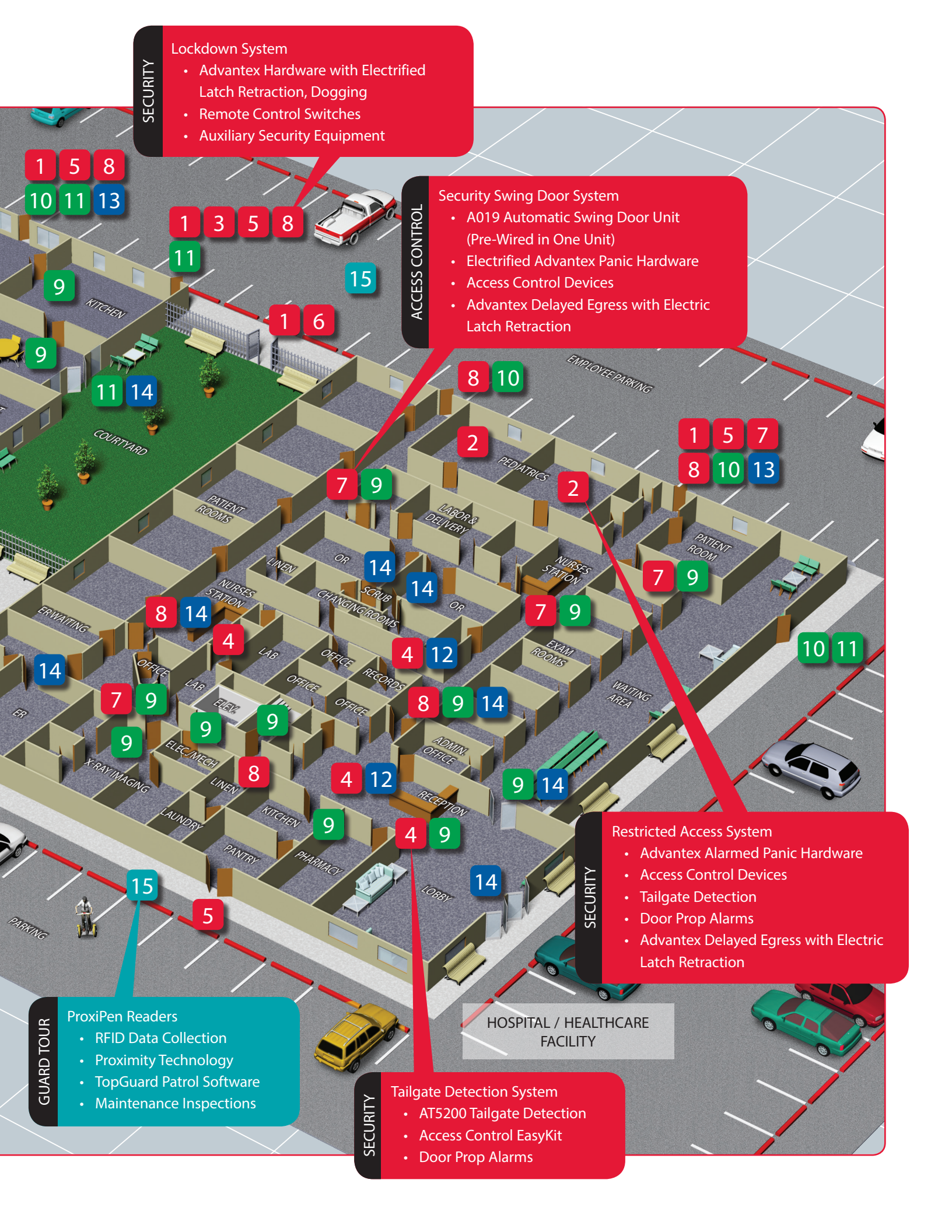

HOSPITAL / HEALTHCARE FACILITY



## Access control doors to security doors — Detex handles them all

A wide range of Detex products are at work in the healthcare industry, wherever safety, security and ease of maintenance are paramount. Whether your order is for new construction or retrofitting an older building, Detex life safety and security hardware can provide the right solution from an extensive inventory of products engineered to suit your requirements.

For front, side or back exterior doors, interior passages or outdoor gates, for electrified options or the simplicity of EasyKits, for the extra security of DX bolts or state-of-the-art guard tour systems, for Advantex designs that complement architectural styles — for any life safety and security hardware application at your healthcare facility, Detex has the answer. And anti-microbial coating is an option if you prefer.

As panic hardware takes on an even more critical role in protection for entrance and egress, the healthcare industry is recognizing the quality and variety that Detex brings to the job. Detex has become a driving force in the advancement of life safety and security hardware, meeting today's healthcare needs without compromise.

### Long life, low maintenance and repair costs

Durable and well-made, Detex products are designed to last a long time with fewer problems, and that means savings in maintenance and replacement costs. Because we constantly solicit input from our customers to ensure that our products are meeting our high standards in the field, we have learned that you truly appreciate the value of quality. Locksmiths like the ease of installation, maintenance people are pleased with the dependability, architects recognize the handsome design. They all put their trust in Detex for trouble-free performance.

As always, our customer support staff is ready to answer your questions about your specific healthcare applications.





Detex Corporation  
302 Detex Drive  
New Braunfels, TX 78130  
800-729-3839  
830-629-2900  
830-620-6711 (fax)

[www.detex.com](http://www.detex.com)  
[marketing@detex.com](mailto:marketing@detex.com)

