

PDCPD Large Diameter Butterfly Valve (28" - 48")

Specifications

Sizes: 28" – 48"
Models: Wafer Style
Operators: Gear
Bodies: PDCPD
Discs: PDCPD
Seats: EPDM, FKM
Stems: 403 Stainless steel
Max Working Press: 110psi
Max Working Temp: 175° F

Standard Features

- High corrosion resistance PDCPD body
- Lightweight – Considerably lighter than metallic valves of same size
- Wafer style body design
- Full seat liner design
 - Eliminates mating flange gaskets
- Spherical disc design
 - For maximum flow characteristics
- Non-wetted metal parts
 - No metal to media contact
- ISO 5211 F-series top flange
- 304 stainless steel stem
- Durable cast iron epoxy coated gear operator
- Class 6 bubble-tight shut-off

Options

- 2" square operating nut on gear operator

Sample Specification

All PDCPD butterfly valves sizes 28"– 48" shall be of the lined body design and feature a Class 6 bubble-tight seal, with only the liner and disc as wetted parts. Gear operators shall be self-locking worm gear design, with cast iron body and corrosion resistant epoxy finish. The disc shall be spherical design for long life. Liner shall be convex ring face design for lower bolt torque and be molded and formed around the body doubling as mating flange gaskets. Stem shall be 403 stainless steel, non-wetted and of two-piece design. Valves shall have ISO 5211 molded bolt pattern on top flange. All valves shall be rated to a maximum of 110psi at 70° F, as manufactured by Asahi/America, Inc.

Parts List

PARTS			
No.	DESCRIPTION	PCS.	MATERIAL
1	Body	1	PDCPD
2	Disc	1	PDCPD
3	Seat	1	FKM, EPDM
4	O-Ring (A)	11	FKM, EPDM
5	O-Ring (B)	3	FKM, EPDM
6	O-Ring (C)	1	NBR
7	O-Ring (D)	1	NBR
8	Stem (A)	1	Stainless Steel 403
9	Stem (B)	1	Stainless Steel 403
10	Key (A)	1	Carbon Steel
11	Key (B)	4	Carbon Steel
12	Bush	2	Bronze Casting (For EPDM Liner) PVDF (For FKM Liner)
13	Gasket (A)	1	Nonas Sheet
14	Stem Holder	1	Stainless Steel 304
15	Bolt (A)	6	Stainless Steel 304
16	Gear Box	1	Cast Iron (FC200 With Epoxy Coat)
17	Thrust Ring (A)	1	UHMWPE
18	Bolt (B)	8	Stainless Steel 304
3a	Stabilization Ring (A)	2	Stainless Steel 304
1a	Inserted Metal of Body	1	Carbon Steel (FCD450)
1b	Inserted Metal of Disc	1	Carbon Steel (FCD450)

PDCPD Large Diameter Butterfly Valve

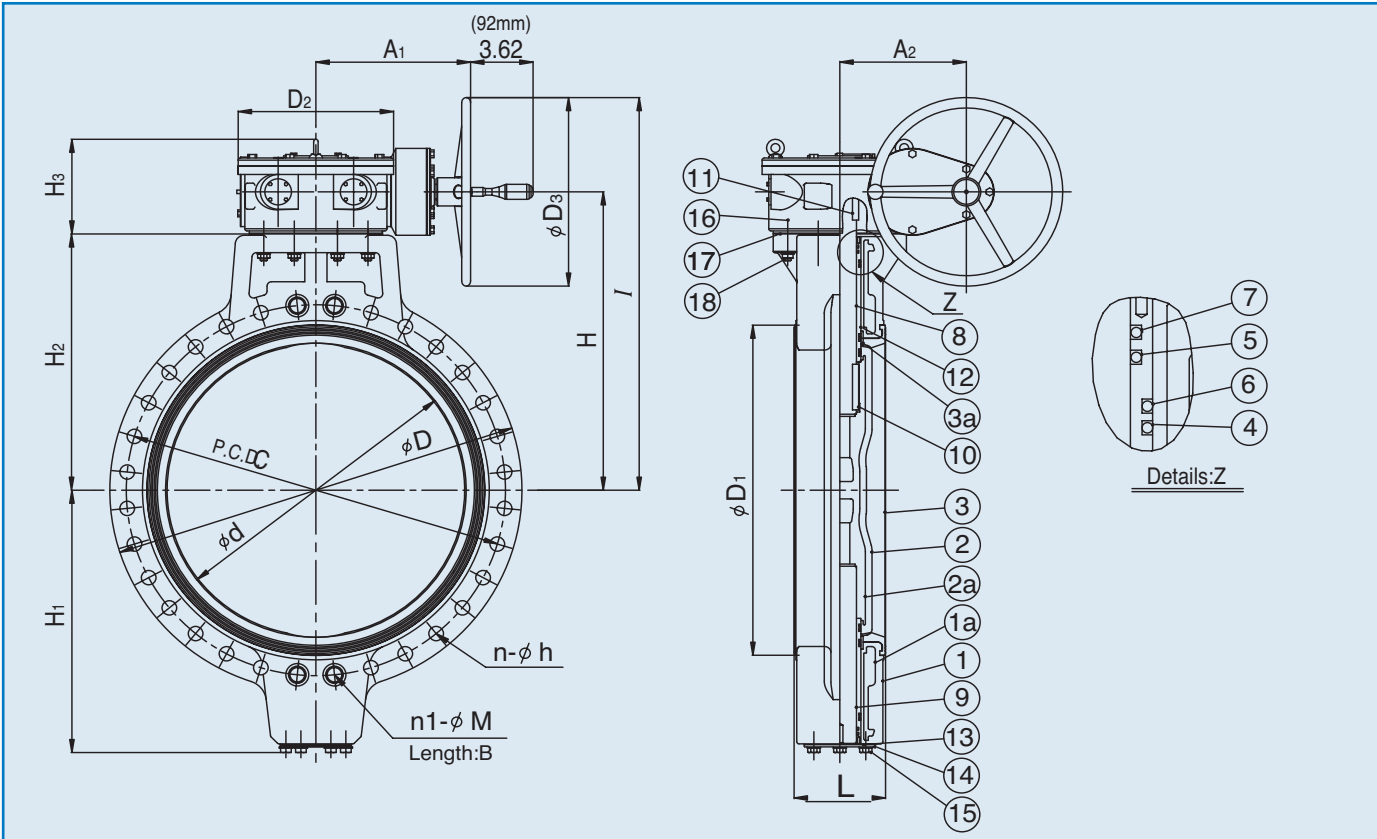

Dimensions (in.)

INCHES	mm	d	C	n	h	h1	M	B	D	D1	D2	D3	L	A1	A2	H1	H2	H3	H	I	Gear Box Model
28	700	26.38	34.00	24	1.38	4	1-1/4	1.38	36.54	29.92	13.78	17.13	8.11	15.83	11.22	23.19	23.23	9.76	26.97	35.31	BRF10
32	800	30.31	38.50	24	1.62	4	1-1/2	1.38	41.34	34.25	13.78	17.13	9.45	15.83	11.22	24.37	24.41	9.76	28.15	36.50	BRF10
36	900	34.25	42.75	28	1.62	4	1-1/2	1.38	45.98	38.50	13.78	25.00	9.45	15.83	11.22	27.72	27.76	9.76	31.50	44.00	BRF10
40	1000	38.19	42.75	32	1.62	4	1-1/2	1.65	50.00	42.52	18.11	25.00	11.81	22.20	9.53	29.49	29.52	10.39	33.27	45.55	BRF10
44	1100	42.52	51.75	36	1.62	8	1-1/2	1.77	54.33	47.05	-	25.00	11.81	22.24	9.02	30.71	33.07	12.72	39.84	52.36	BRF10
48	1200	46.06	56.00	40	1.62	8	1-1/2	1.77	58.58	51.18	-	25.00	13.78	22.24	9.02	33.46	35.04	12.72	41.81	54.33	BRF10

Cv Values

Press. vs. Temp (non-shock)/Weight (lbs.)

NOMINAL		Cv		
INCHES	mm	30°	60°	90°
28	700	3,600	13,000	32,000
32	800	4,200	17,000	43,000
36	900	5,600	22,000	55,000
40	1000	7,000	26,000	70,000
44	1200	6,450	36,550	86,000
48	1400	7,500	42,500	100,000

NOMINAL SIZE		Press. Vs. Temp.		Weight (Lbs)
INCHES	mm	30-120° F	121-175° F	
28	700	110psi	70psi	840
32	800	110psi	70psi	1015
36	900	110psi	70psi	1215
40	1000	110psi	70psi	1830
44	1200	110psi	97.5psi	2205
48	1400	110psi	97.5psi	2426

