

Classic

ceia An ISO 9001 Company

GSA Contract Holder

WALK-THROUGH METAL DETECTOR

- High level of Detection Uniformity
- Leading Edge Technology
- Quick installation
- Easy to use
- Suitable for portable applications
- No Maintenance required
- Affordable pricing



EASY TO
INSTALL

THE MOST USER FRIENDLY WALK-THROUGH METAL DETECTOR

The Classic is a Walk-Through Metal Detector designed and engineered to meet the specific security needs of public facilities such as schools, hotels, amusement parks and city halls. ▶

www.ceia-usa.com



Classic WALK-THROUGH METAL DETECTOR



The Classic Metal Detector combines the required Security with a high level of operating efficiency. The leading edge technology features a high flow rate of people through the gate with the minimum number of nuisance alarms, as personal items such as coins, keys and belt buckles can pass through the magnetic field without causing an alarm.

The Classic Metal Detector is compact and lightweight, making this portable unit adaptable to any surroundings. The patented cylinder design is aesthetically suitable for the most discrete applications.

This security equipment does not require any special training for normal use, the most "user friendly" walk-through metal detector in the industry.

CEIA Metal Detectors have been selected by leading security agencies worldwide to protect high-ranking government officials. The Classic conforms to all International Security Standards and is capable of detecting both magnetic and non-magnetic weapons.

When security, operating efficiency and affordable pricing are required, the CEIA Classic Metal Detector is the obvious solution.

MAIN FEATURES

DIGITALLY-ADJUSTABLE SENSITIVITY WITH A WIDE RANGE OF VALUES

ALL FUNCTIONS PROGRAMMABLE and controlled by a microprocessor

PROGRAMMING access protected by hardware key

MULTIPLE INSTALLATIONS: automatic synchronization between two or more metal detectors with a reciprocal distance of down to 2" (5 cm) without the use of cables

PROFESSIONAL HIGH INTEGRATION AND RELIABLE ELECTRONICS

CONTROL UNIT incorporated into the detector

No initial or periodic calibration

EASY MAINTENANCE: modular control unit for a rapid replacement

Color: light grey RAL 7040

INSTALLATION DATA

POWER SUPPLY: 100/115/230 VAC, +10/-20%, 45 ÷ 65 Hz, 20 VA max

OPERATING TEMPERATURE: -4°F to 158°F

STORAGE TEMPERATURE: -31°F to 158°F

RELATIVE HUMIDITY: 0 to 95% (without condensation)

ALARM MODES

VISIBLE SIGNALS High intensity display
Green and red metering signals proportional to the mass of the object detected

AUDIBLE SIGNALS High acoustic intensity alarm signal
Volume and tone of alarm signal can be programmed

CERTIFICATION AND CONFORMITY

Complies with Regulations relating to pacemakers, defibrillators or other vital support systems, pregnant women and magnetic storage media (floppy disks, audio cassettes, video cassettes and similar)

Complies to the current International Security Standards for Walk-Through Metal Detectors

Complies with EC Regulations and International Standards relating to Electrical Safety and Electromagnetic Compatibility (EMC)

ACCESSORIES

MBSU-1 Unit is a portable device designed to supply CEIA Metal Detectors in outdoor applications or in situations where mains power supply is unavailable.



STABILIZING PLATES

METAL DETECTOR DIVESTING TABLE: this article acts both as a spacer between the X-ray unit and the Metal Detector and as a temporary depository for metal personal effects



TRANSPORT BAG Protects the Metal Detector during transport and storage



TEST SAMPLES

APPLICATION FIELDS

- Government agencies
- Schools
- Hotels
- Amusement parks
- Public Events
- Night Clubs

THE CLASSIC/NAVY MODEL IS PARTICULARLY SUITABLE FOR ENVIRONMENTS WITH LIMITED HEADROOM, AND FEATURES AN ELECTRONICS UNIT IN A STAINLESS STEEL IP65 CONTAINER



GREEN AND RED METERING SIGNALS PROPORTIONAL TO THE METAL MASS DETECTED

UNDER THE ALARM THRESHOLD

- * Small metal mass
- *** Medium metal mass

OVER THE ALARM THRESHOLD

- ** Medium metal mass
- *** Large metal mass

DIMENSIONS

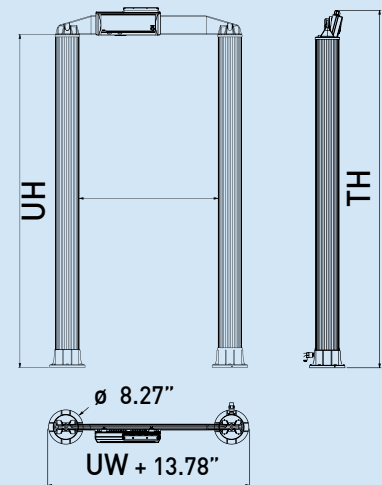

	CLASSIC	CLASSIC/NAVY
UW	28.35"/32.28"*	28.35"/32.28"*
UH	77.36"	72.24"
TH	84.72"	78.74"

* AVAILABLE ON REQUEST



CEIA USA Ltd - 9155 Dutton Drive, Twinsburg OH - 44087 USA
Phone: 330-405 3190 - Fax 330-405 3196 - e-mail: sales@ceia-usa.com

www.ceia-usa.com

CEIA USA reserves the right to make changes, at any moment and without notice, to the models (including programming), their accessories and options, to the prices and conditions of sale

Call 888-532-CEIA

DP040K0002v1000US-44807