

Transport Case for CEIA Elliptic Metal Detector Gate



GSA Contract Holder

CASE GENERAL FEATURES

Composition

- Aluminium Metal Frame
- High Resistance Composite walls
- Antishock construction
- PE shock absorbing filling
- Lockable handles
- Integrated wheels

Weight: 150 lbs (68 kg)

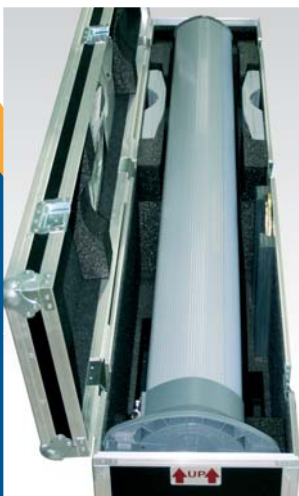

www.ceia-usa.com

EXAMPLE OF INSTALLATION



CASE CONSTRUCTION

- Flight case constructed in multilayered phenolic birch
- External covering in black embossed plastic laminate
- Finished with heavy-duty aluminium drawpieces
- Three cavity closures with anti-intrusion lock
- Cavity-mounted lid hinges
- Ten cavity-mounted handles
- Six heavy-duty pivoting wheels with brakes
- Six castor checkers
- Interior lined with moquette and modelled black Ethafoam

OVERALL DIMENSIONS

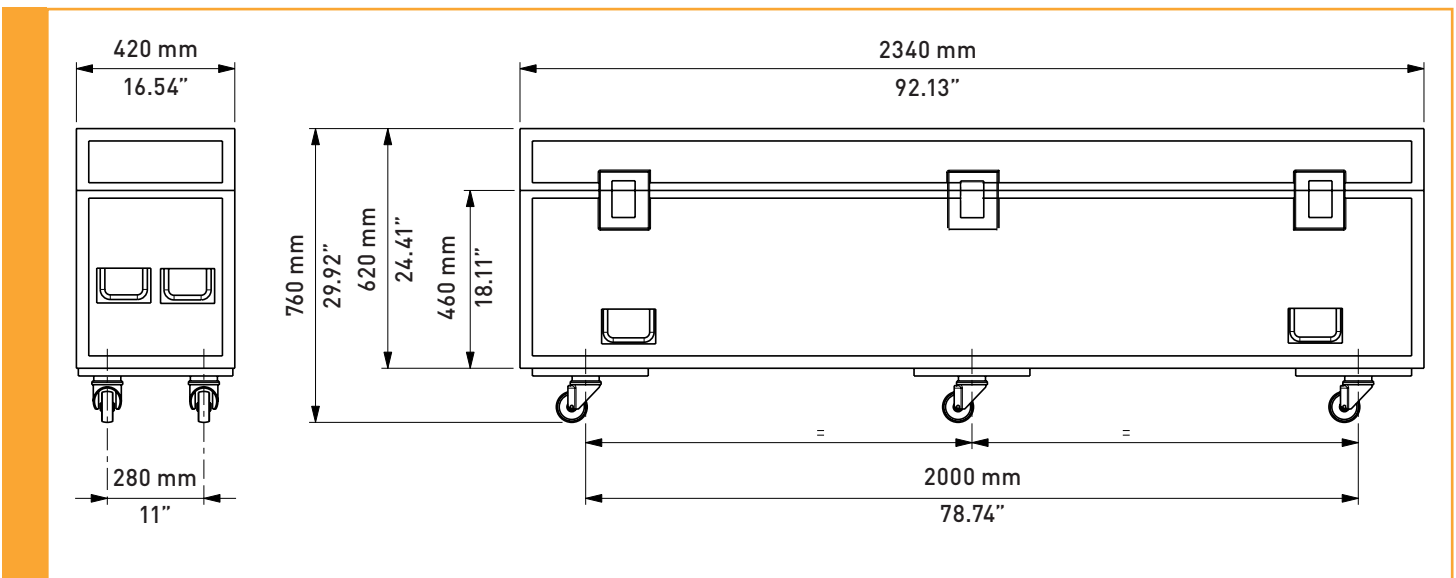

CEIA USA Ltd - 9155 Dutton Drive, Twinsburg OH - 44087 USA
 Phone: 330-405 3190 - Fax 330-405 3196 - e-mail: sales@ceia-usa.com

www.ceia-usa.com

Call 888-532-CEIA