

770 and 771 Security Command™ Keypads

Description

The DMP 770 and 771 Security Command keypads provide an attractive, user-friendly control with optional 2-button Panic keys for use with DMP Command Processor™ panels. Each keypad provides supervised or unsupervised operation, an easy-to-read 16-character fluorescent blue display, an AC LED, backlit keyboard, low profile styling, and a choice of designer colors to compliment a variety of room decors.

You can also connect a variety of burglary and non-powered fire devices to the four programmable expansion zones on the 770 and 771 keypads. Additionally, the 771 provides an internal Form C door strike relay for controlling magnetic locks or electric door strikes on protected entrances.

AC LED

The keypads contain an AC LED that turns off when AC power to the panel is off or while the panel resets.

771 Door Strike Relay

The 771 provides one Form C (dry contact) relay output for controlling magnetic locks or electric door strikes on protected doors. These devices connect to the Violet (N/C), Gray (Common), and Orange (N/O) conductors on the harness supplied with the 771 keypad. The relay contacts are rated for 1 Amp at 24 VDC.

Harness Color Code

Refer to Figure 1 for harness connections and color codes. The Form C relay output 3-wire Orange, Gray, and Violet harness is only available on the 771 model.

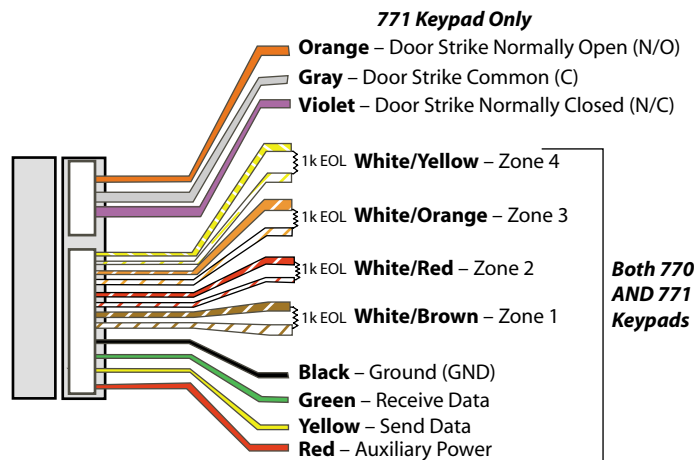

Figure 1: 770/771 Wiring Harness

Wiring Specifications

Several factors determine the performance characteristics of the DMP LX-Bus™ and keypad bus: the *length* of wire used, the *number* of devices connected, and the *voltage* at each device. When planning an LX-Bus™ and keypad bus installation, keep in mind the following four specifications:

1. DMP recommends using 18 or 22-gauge unshielded wire for all keypad and LX-Bus circuits. **Do Not** use twisted pair or shielded wire for LX-Bus and keypad bus data circuits. All 22-gauge wire must be connected to a power-limited circuit and jacket wrapped.
2. On Keypad bus circuits, to maintain auxiliary power integrity when using 22-gauge wire do not exceed 500 feet. When using 18-gauge wire do not exceed 1,000 feet. To increase the wire length or to add devices, install an additional power supply that is UL listed for Fire Protective Signaling, power limited, and regulated (12 VDC nominal) with battery backup.

Note: Each panel allows a specific number of supervised keypads. Add additional keypads in the unsupervised mode. Refer to the panel installation guide for the specific number of supervised keypads allowed.

3. Maximum distance for any one bus circuit (length of wire) is 2,500 feet regardless of the wire gauge. This distance can be in the form of one long wire run or multiple branches with all wiring totaling no more than 2,500 feet. As wire distance from the panel increases, DC voltage on the wire decreases. Maximum number of LX-Bus devices per 2,500 feet circuit is 40.

- Maximum voltage drop between the panel (or auxiliary power supply) and any device is 2.0 VDC. If the voltage at any device is less than the required level, add an auxiliary power supply at the end of the circuit. When voltage is too low, the devices cannot operate properly.

For additional information refer to the 710 Installation Sheet (LT-0310) and or the LX-Bus/Keypad Bus Wiring Application Note (LT-2031).

Mounting Options

For mounting 770 or 771 keypads on solid or uneven walls, you can use the DMP Model 776 Metal Keypad Backbox. The 776 is 1/2" deep with a baked enamel finish and provides one 3/4" wire entry hole on the back for convenient wiring.

For applications where conduit is required to the keypad, use the DMP Model 775 Metal Keypad Backbox. The 775 is 1-1/2" deep with three 1/2" and 3/4" knockouts located in the center back and centered on two sides for connecting conduit.

To provide additional keypad protection against tampering or unauthorized use, install the DMP Model 777 Plastic Keypad Cover to provide a wall-mounted clear 1/8" thick polycarbonate housing with lifting cover and integral locking mechanism. Refer to 777 Install Guide (LT-0175).

Additional Power Supply

If the current draw for all keypads connected to the panel exceeds the panel output, you can provide additional current by adding an auxiliary power supply. Connect all keypad Ground (common) wires to the power supply negative terminal.

Run a jumper wire from the power supply negative terminal to panel terminal 10. Connect all keypad power (+12 VDC) wires to the power supply positive terminal. Do NOT connect the power supply positive terminal to any panel terminal.

Note: The power supply must be UL Listed for use with Burglar Alarm Systems.

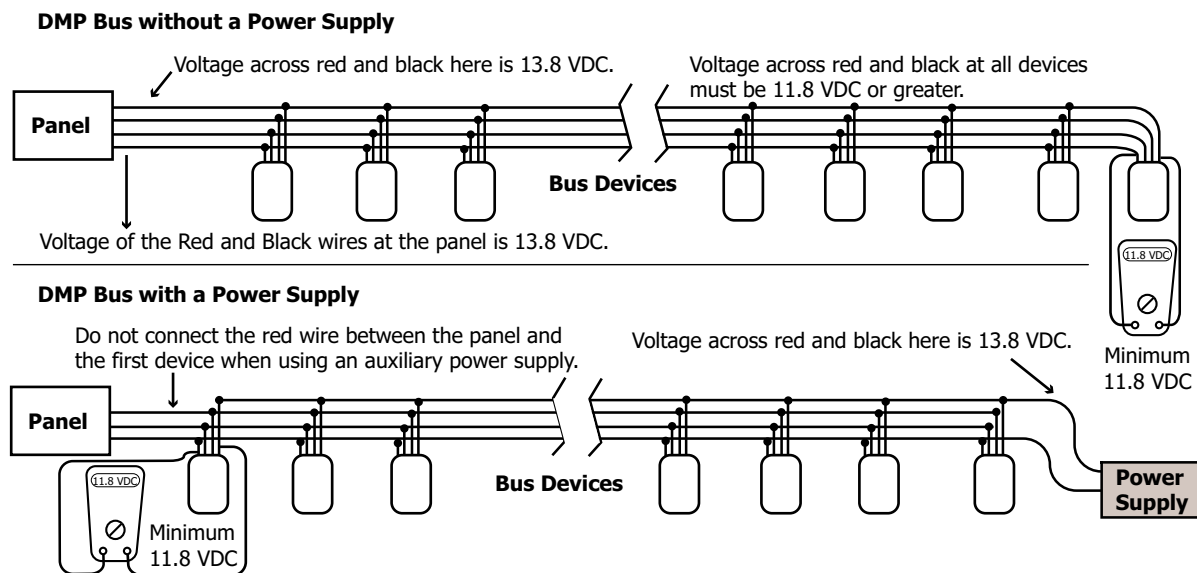

Figure 2: Power Supply and Maximum Voltage Drop

2-Button Panic Keys

The 770 and 771 keypads also provide an optional Panic key function that allows the user to easily send a Panic, Emergency, or Fire report to the central station. The user presses and holds two top row Select keys for two seconds until the keypad beeps. Figure 3 shows Panic key label placement.

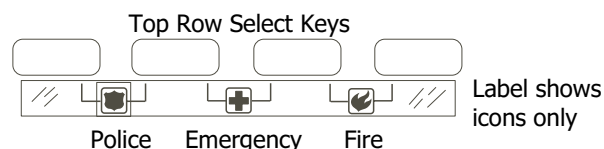

Figure 3: Panel Key Label Placement

At the beep, the panel sends the following zone alarm reports to the central station: **Panic** (left two Select keys) - Zone 19, non-medical **Emergency** (center two Select keys) - Zone 29, and **Fire** (right two Select keys) - Zone 39.

The Panic key function activates as soon as you apply power to the keypad. No additional zone programming is necessary. If the system owner intends to use the Panic keys, install the supplied icon label below the top row of Select keys. To disable the 2-button Panic keys, cut **J8** jumper located at the bottom left side of the keypad circuit board.

7/0 Panic Keys

The Security Command keypads also allow the user to initiate a Panic alarm by pressing the 7 and 0 (zero) keys simultaneously when zone 1 on the assigned keypad address is programmed as a Panic-type zone. Place a 1k Ohm End-of-Line resistor across the White/Brown pair of zone wires (Zone 1).

To disable the 7/0 Panic key feature, cut **J7** jumper located on the bottom left side of the keypad circuit board.

Unsupervised Operation

The 770 and 771 Security Command keypads also allow **unsupervised** operation to connect multiple keypads to one of the panel's available keypad addresses. This feature greatly expands the number of keypads you can install to give users the maximum flexibility in system operation. Unsupervised keypads communicate with the panel only when keys are pressed by the user and work on all DMP panels. See **Address Programming** below. Keypads must be supervised if they are programmed for Device Fail Output. Refer to the panel installation or programming guide for more information on using the Device Fail Output.

Address Programming

Use the slide switches numbered 1, 2, and 3 on the left side of the circuit board to set the keypad to one of the panel's eight available addresses. Move slide switch number 4 *down* for supervised operation and *up* for unsupervised operation. Multiple unsupervised keypads can be assigned the same address. See Figure 4 for keypad switch addressing.

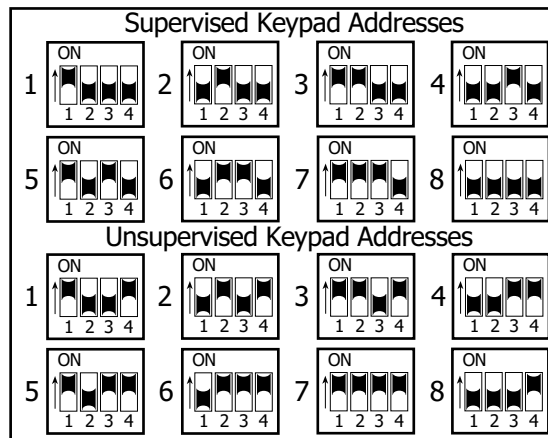

Figure 4: Addressing Switches

Table 1 lists the DMP panels and indicates the number of supervised keypads the panel supports.

DMP Command Processor Panel	Number of Supervised Keypads *
XRSuper6, XR20	4
XR5	2
XR40, XR200, XR2400F	8
* XR200-485	8
* XR200-485 panel supports 16 supervised keypads. The 770, 771 Keypads only support 8 supervised keypads.	

Table 1: DMP Panels and Supervised Keypads

Dimming the Keypad Display

As an added customer convenience, pressing and holding the COMMAND and Back Arrow keys for two or more seconds turns off the vacuum fluorescent display, keyboard backlighting, and Power LED. These indicators are restored whenever the keypad speaker is turned on or any key on the keyboard is pressed.

The keyboard backlighting turns off automatically after 30 seconds if no keys are pressed and the trouble buzzer is not active.

Self-Test Diagnostics

The 770 and 771 keypads allow you to test all system keypad functions. To test the keypads:

- Disconnect the red (+12 VDC), yellow, and green keypad wires from the panel.
- Twist the yellow and green keypad wires together. Reconnect the red wire to the panel.

To go to the next test, press the COMMAND key. To repeat a test, press the Back Arrow key.

TEST 1 DISPLAY TEST

This test begins immediately and scrolls a series of characters across the display allowing you to visually inspect each segment of the display.

TEST 2 KEY TEST

This allows you to check each key for proper operation. The display shows: **PRESS KEY—** . As you press and hold each key, its number displays as **KEY X** (X represents the key number).

TEST 3 ZONE TEST

This allows you to check each keypad zone for proper operation. The display shows: **L1 L2 L3 L4**. Following each zone number is the zone status. (O) = Open, (-) = OKAY, and (S) = Short.

TEST 4 FUNCTION TEST

This allows you to check the AC LED, relay, and keypad tone for proper operation. The display reads: **LED RLY TONE**. To test each function, press the select key beneath the name of the function. The keyboard backlight turns off during this test. The RLY (relay) function is only available on 771 keypads.

TEST 5 ADDRESS TEST

This test displays the keypad address selection. The display **ADDRESS 3 U** indicates the keypad being tested is set to address 3 and is also unsupervised. Supervised keypads show only the address number. To end the Address Test, press COMMAND.

Reconnecting the keypad wiring

Disconnect the red wire from the panel. Separate the yellow and green keypad wires and reconnect them to the panel. Connect the red wire to the panel. Press COMMAND to start normal keypad operation.

Additional Diagnostics

If a key is pressed and the keypad has not been polled by the panel within the past 5 seconds, the keypad displays **SYSTEM BUSY**.

Also, if at any time during normal operation a supervised keypad cannot detect polling from the panel for 90 seconds, the display shows: **SYSTEM TROUBLE**. This could indicate a broken green wire, reset jumper installed, or a problem with the keypad.

If a supervised keypad detects polling, but its particular address is not being polled, the display shows: **NON-POLLED ADDR**. To clear this display, check the keypad address selection or the number of keypad addresses you have assigned during system programming.

Specifications		Accessories	
Operating Voltage	8.0 VDC to 16 VDC	775	Keypad Conduit Backbox
Current Draw		776	Keypad Backbox
Standby:	100mA + 1.6mA per active zone	777	Protective Keypad Cover
Alarm:	100mA + 2mA + 20mA w/ annunciator ON	777G	Weatherproof Cover Gasket
771 Internal Relay	30mA when door strike is activated	777S	Cover Spacer
		779	Keypad Deskstand
		WR-0012	Replacement Harness
		WR-0512	Replacement 5-foot Harness



DMP
Digital Monitoring Products

800-641-4282

www.dmp.com

Made in the USA

INTRUSION • FIRE • ACCESS • NETWORKS

2500 North Partnership Boulevard

Springfield, Missouri 65803-8877