

Small Piece Ironer

Comet Executive™

CHICAGO®



America's Finest Compact Flatwork Finisher

The Comet Executive is the highest producing compact finisher available for use in a wide variety of restaurant, club and banquet operations looking for high output and quality finish. The Comet Executive's full 14" (350mm) diameter "deep chrome" heated roll produces 15 to 20% more finished linen per hour with the highest BTU/heat generation capacity of any compact ironer. Comet Executive features the heavy-duty construction, easy feeding canvas input ribbon loading and compression roll similar to Chicago's larger equipment. Full exhaust canopy with wraparound insulated heat shield keeps heat working inside the ironer instead of escaping into the laundry room. A 1/3 HP motor driven blower and touch control AC frequency inverter variable speed drive are standard on all models which are offered in a choice of high efficiency gas heated, ASME approved steam heated and reliable electric heated cylinders, to match the heat source that best suits the location.

Comet Executive

Dimensions and Utilities

NOTE:

1. Specifications subject to change without notice. Consult factory for certified construction floorplan.
2. Millimeter dimensions are in [].
3. All dimensions are +/- 1/2".
4. Utility connections are located as shown.

Side View

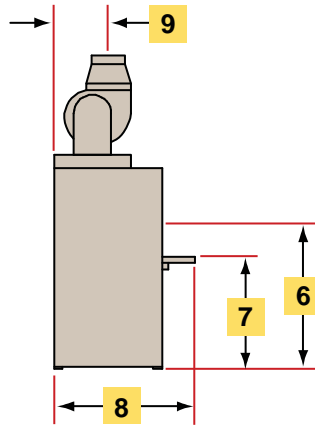

Front View

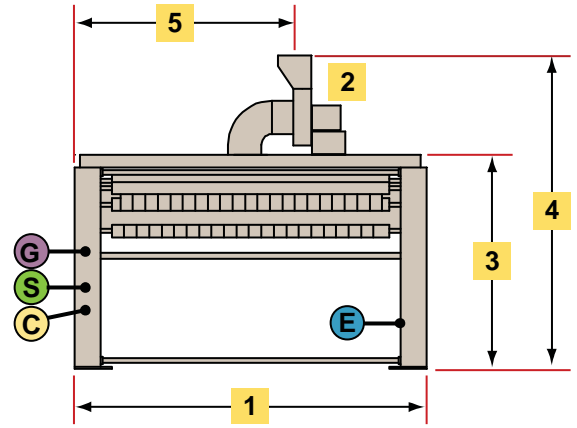

Comet Executive

56" | 66" | 80"

Electrical - Gas		AT 7" HT. [178]	1	75" [1905]	85" [2153]	99" [2508]
Electrical - Steam		AT 7" HT. [178]	2	8" VENT		
Electrical - Electric		AT 10-1/2" HT. [267]	3	52" [1308]		
Gas Connection		1/2" AT 28-1/2" HT. [724]	4	76" [1918]		
Steam Inlet		1/2" AT 20" HT. [508]	5	53" [1346]		
Condensate Return		1/2" AT 15" HT. [381]	6	35" [889]		
			7	27" [686]		
			8	34" [864]		
			9	13" [330]		

Features

Standard Features

- Heavy duty chrome plated oversized heated 14" (350mm) diameter cylinder available in 80" (2000mm), 66" (1600mm) or 56" (1400mm) useable width for wax-free operation
- Choice of gas, steam or electric heated cylinder
- 10-35 FPM speed range — fastest in its class
- Dries and irons tabletops, pillowcases, napkins and other linen — including 100% cotton, polyester/cotton and VISA® blends
- OEM upgraded Hi-Lyfe® ribbons for substantially longer textile life
- Gas heated models available for all types of gas

A Complete Range of Separating, Feeding, Ironing, Folding, and Sorting Options

Because Chicago specializes only in flatwork finishing equipment, it can offer the world's widest range of high production separating, feeding, ironing, folding and sorting equipment. Complete flatwork finishing systems range from automated multi-roll systems producing over 2000 pounds per hour, to compact ironers for small on-premise laundries.

Chicago's performance record is unmatched in thousands of installations in commercial, hospitality, health care, textile rental, institutional and on-premise laundries all over the world. An experienced Chicago professional will be pleased to make an objective equipment recommendation based

on your production, space, utility and budget requirements. Contact your local Chicago distributor or the factory sales assistance office for a no-obligation analysis of your needs.

Chicago's Customer Service department offers full technical and service support by telephone and on our website. We also offer overnight service for quick parts availability. Visit our website, www.chidry.com, to learn more about our complete line of flatwork finishing systems, including video of Chicago® equipment in action.

CHICAGO®



CHICAGO DRYER COMPANY

2200 North Pulaski Road
Chicago, Illinois 60639-3737 USA

Phone • 773.235.4430
Fax • 773.235.4439

Web • www.chidry.com
Email • chicago@chidry.com

Bulletin #7572