

COMMERCIAL PRODUCTS CATALOG

Mini Ball Valves

94 MBV SERIES



MINI BALL VALVE – APOLLO INTERNATIONAL™

Designed for commercial and light industrial use. Conventional port, constructed of heavy-duty forged brass, PTFE seats and gland follower with double viton o-rings, to prevent stem leakage.

FEATURES

- Reversible handle
- Blowout-proof stem
- Double Viton o-ring stem seals
- Large raised wrench flats
- Chrome plated brass ball
- Maximum 600 psig at 100°F, non-shock
- Temps from -40°F to 300°F
- ANSI Z21.15-2009 / CSA 9.1-2009 (1/2 psi) Manually Operated Gas Valves for Appliances.
- ASME B16.44-2002 Manually Operated Metallic Gas Valves for use in Above Ground Piping Systems (2 and 5 psig).
- MSS-SP110 compliant

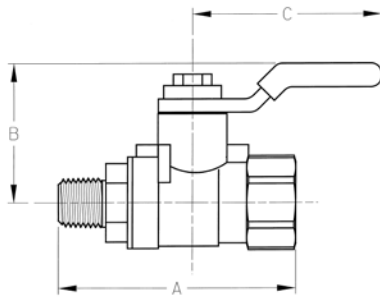

Model Number	Size (in.)	Dimensions (in.)			Port Ø	Wt. (lbs.)
		A	B	C		
94-MBV-01	1/4 FNPT x 1/8 MNPT	1.95	1.09	1.65	0.31	0.19
94-MBV-02	1/4 FNPT x 1/4 MNPT	1.95	1.09	1.65	0.31	0.20
94-MBV-03	1/4 FNPT x 1/4 FNPT	1.95	1.09	1.65	0.31	0.17
94-MBV-04	1/8 FNPT x 1/8 MNPT	1.95	1.09	1.65	0.31	0.16
94-MBV-05	1/8 FNPT x 1/8 FNPT	1.95	1.09	1.65	0.31	0.16

General Purpose Uni-Body Valves

9A-100 SERIES



HEAVY PATTERN UNI-BODY THREADED BALL VALVE

One piece bronze valve eliminates leak paths. Features static grounding devices and adjustable packing gland. Lever handle standard.

FEATURES

- Rated 600 psig CWP, non-shock
- 150 SWP
- Blowout-proof stem design

OPTIONS INCLUDE:

- Cam lock option (-30 suffix)
- Round handle option (-15 suffix)
- Latch lock handle option (-27 suffix)

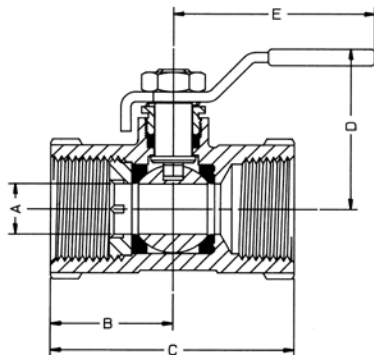

Model Number	Size (in.)	Dimensions (in.)				
		A	B	C	D	E
9A-101-01	1/4	0.37	1.34	2.59	1.68	3.87
9A-102-01	3/8	0.37	1.34	2.59	1.68	3.87
9A-103-01	1/2	0.37	1.34	2.59	1.81	3.87
9A-104-01	3/4	0.50	1.44	2.84	1.84	3.87
9A-105-01	1	0.62	1.72	3.28	2.00	4.87
9A-106-01	1-1/4	0.81	1.94	3.84	2.18	4.87
9A-107-01	1-1/2	1.00	2.06	4.00	2.68	5.50
9A-108-01	2	1.25	2.29	4.56	2.87	5.50