

Linen Transition Conveyor

The Bridge™

CHICAGO®



BRIDGE THE GAP...

...to Smoother Linen Flow, Reduced Manual Linen Handling and Better Finished Stack Quality



The Bridge linen transition conveyor neatly transfers stacks of folded linen from a large piece or towel folder onto a master linen conveyor system. After receiving stacked linen directly from a folder's discharge conveyor, the Bridge's motor-driven roll advances the stack across its heavy duty mini-conveyor.

Immediately, or after a slight delay if there is passing traffic on the master conveyor, a belt drive system moves both the linen stack and Bridge mini-conveyor to a position extended slightly above the master conveyor. Linen continues to be moved forward by motor-driven ribbons and is automatically unloaded onto the master conveyor as the Bridge retracts to its original position – ready for the next stack. The result is neatly and correctly positioned stacks of linen successfully merged into the flow of the master conveyor without tipping or colliding with linen from other production lines.

The Bridge

Dimensions and Utilities

CONNECTION(S)	DIA.	HEIGHT
E Electrical Connection	-	11" [279]

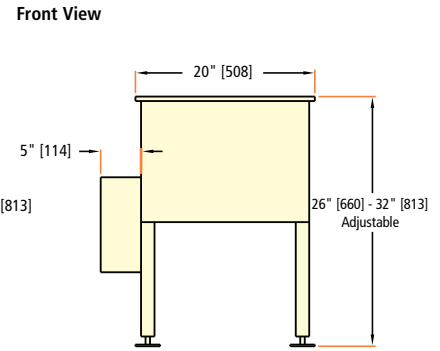
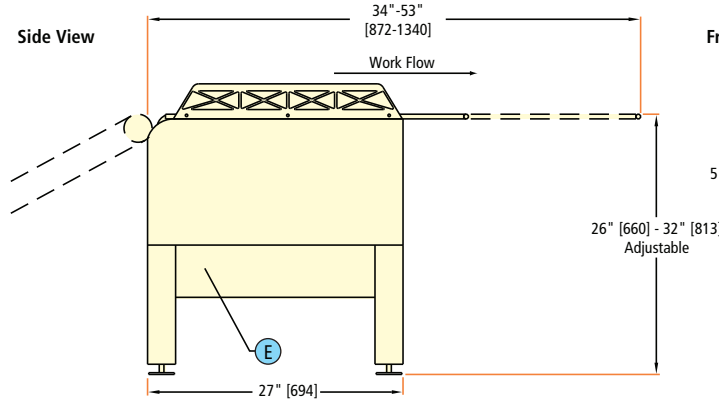
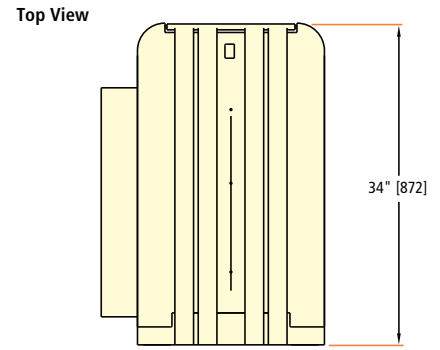

NOTE:

1. Specifications subject to change without notice. Consult factory for certified construction floor plan.
2. Millimeter dimensions are in [].
3. All dimensions are $\pm 1/2"$.
4. Utility connections are located as shown.

NOTE:

To accommodate king/queen sheets or oversized banquet linen, the Bridge's dimensions may increase slightly. Consult factory for details.

Features

- Powerful rack and pinion indexing method works with hardened and polished rod and ball bearing support guides
- Stacks are moved across the shortest, straightest path to the master conveyor without the need for an extra rotating mechanism
- Stacks are discharged with their long side oriented across the master conveyor so they occupy less running conveyor length and make better use of the master conveyor space
- Stacks are positioned on master conveyor in correct orientation for use with automatic tying machine
- Allows more finished stacks to be positioned, stored and moved on the master conveyor without disrupting linen coming from other folders
- All movements are activated by reliable photocell and controlled by **CHI** microprocessor and proximity sensors
- Adjustable legs allow proper mating with most conveyor heights
- Easy electrical connections can be made to Chicago large or small piece conveyor/stacker for ease of use with other machines
- Automatic linen "Traffic Control" senses items on master conveyor and regulates Bridge movements and timing of discharges. Optional control box for coordinating multiple Bridge systems available, (Consult factory for additional information and pricing)

A Complete Range of Separating, Feeding, Ironing, Folding and Sorting Options

CHICAGO offers a complete line of flatwork separators, feeders, ironers and folders for a well-matched finishing package for any size installation. Chicago's performance record is unmatched in thousands of installations in commercial, hospitality, health care, textile rental, institutional and on-premise laundries all over the world. An experienced Chicago professional will be pleased to make an objective equipment recommendation based on your production, space, utility and budget requirements.

Contact your local Chicago distributor or the factory sales assistance office for a no-obligation analysis of your needs.

Chicago's Customer Service department offers full technical and service support by telephone and on our website. We also offer overnight service for quick parts availability. Visit our website, www.chidry.com, to learn more about our complete line of flatwork finishing systems, including video of Chicago® equipment in action.



CHICAGO DRYER COMPANY
2200 North Pulaski Road
Chicago, Illinois 60639-3737 USA

Phone • 773.235.4430
Fax • 773.235.4439
Web • www.chidry.com
Email • chicago@chidry.com