

High-Production Small Piece Folder

**AIR** CHICAGO  
*EXPRESS*

**CHICAGO**<sup>®</sup>



## **A dedicated new maximum speed version of America's most popular small piece folder series that performs French or 1/2 folds on a variety of items**

Chicago introduces the best of both worlds—a new Air Chicago Series model with all the quality, reliability and accuracy of the original Air Chicago in a more streamlined format designed for laundries requiring high speed folding of items up to 35" (854mm) wide, including towels, gowns, pads, and a variety of other items. Narrow footprint saves space and allows one or multiple units to be installed in commercial or on-premise laundries with limited floorspace. For the first time, laundries can replace older design mechanical, less accurate towel folders with Air Chicago quality in the same footprint—while adding the industry leading accuracy of Chicago's patented air pulse folding and state-of-the-art CHI•Touch touchscreen operating, management, and diagnostic control. All backed by Chicago's factory and service support team who have helped make the Air Chicago series the most popular small piece folders in the market for over fifteen years.

# Air Chicago *Express*

## Dimensions and Utilities

### NOTE:

1. Specifications subject to change without notice. Consult factory for certified construction floorplan.
2. Millimeter dimensions are in [ ].
3. All dimensions are +/- 1/2".
4. Utility connections are located as shown.

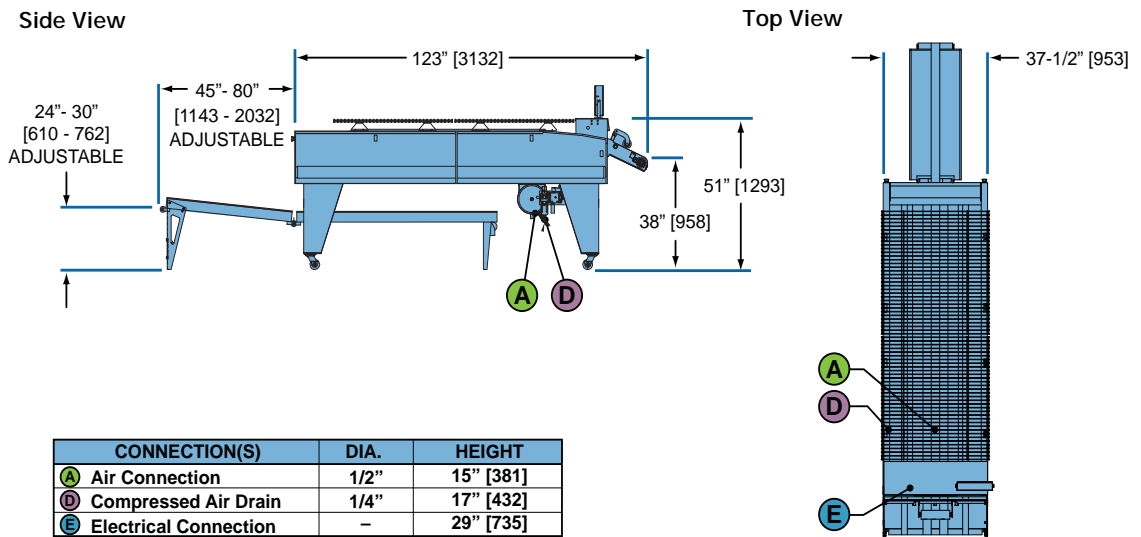

## Features

### Key Features Retained From Original Air Chicago

- Patented precision air-pulse folding and accuracy
- Never a mechanical slide or chop blade
- Makes French or 1/2 folds on a wide variety of items
- Inverter on stacker eliminates mechanical clutch and brake for improved accuracy and consistency
- Alternating air pulses to match item length
- Rear or front delivery

### New *EXPRESS* Features

- Faster throughput with continuously running high-speed conveyor
- Narrower footprint—fits as a direct replacement for older mechanical towel folders
- Stationary segmented air pulse bars
- Longer folding bed within compact footprint
- Improved accuracy and consistency on narrower towels
- Autotune™ (patent pending) automatically sets fold parameters for each item during programming
- Faster acting stacker doors
- Inverter controller exit conveyor for smooth and accurate starting and stopping
- Self-contained exit conveyor with adjustable discharge height

### CHI•Touch Control Screen Features

- PC-based touch screen control with the simplest and most complete set-up, operating, managing, and diagnostic software in the industry
- Allows all folding parameters to be set by a touch of the screen—including number of crossfolds, stack height, and finished item widths
- Tiered, secure coded access ensures only authorized users are permitted to adjust settings in established programs, or to review the detailed data bank, while keeping basic operating controls simple
- Screen also shows real time measurements and component activations and sequencing in diagnostic mode, as well as schematics for troubleshooting

## A Complete Range of Separating, Feeding, Ironing, Folding, and Sorting Options

Because Chicago specializes only in flatwork finishing equipment, it can offer the world's widest range of high production separating, feeding, ironing, folding and sorting equipment. Complete flatwork finishing systems range from automated multi-roll systems producing over 2000 pounds per hour, to compact ironers for small on-premise laundries.

Chicago's performance record is unmatched in thousands of installations in commercial, hospitality, health care, textile rental, institutional and on-premise laundries all over the world. An experienced Chicago professional will be pleased to make an objective

equipment recommendation based on your production, space, utility and budget requirements. Contact your local Chicago distributor or the factory sales assistance office for a no-obligation analysis of your needs.

Chicago's Customer Service department offers full technical and service support by telephone and on our website. We also offer overnight service for quick parts availability. Visit our website, [www.chidry.com](http://www.chidry.com), to learn more about our complete line of flatwork finishing systems, including video of Chicago® equipment in action.



**CHICAGO DRYER COMPANY**  
2200 North Pulaski Road  
Chicago, Illinois 60639-3737 USA

Phone • 773.235.4430  
Fax • 773.235.4439  
Web • [www.chidry.com](http://www.chidry.com)  
Email • [chicago@chidry.com](mailto:chicago@chidry.com)

Patented and patent pending

Bulletin #7557