



- Sized to display 3" x 7" signs and labels
- Built in Color Hi-Res CCTV Camera
- 540TVL 1/3" Sony Imager
- Fixed 3.6mm Wide Angle Lens
- DC 12V @ 92mA
- Securely mounts to any surface
- Adjustable camera angle; 24° total
- Countertop, wall, or ceiling mounting

Sign Camera

The Aigis Sign Camera is designed to discretely capture facial images of patrons while displaying a sign or label. Overhead CCTV cameras can be rendered ineffective if the subject wears a cap or hood. The Sign Camera can be installed at table-height and angled upward to capture facial images that were missed by other cameras.

The Sign Camera includes an adjustable mounting bracket that can be securely mounted and adjusted through 100°. The unit can be configured to mount to any countertop, wall or ceiling. Once installed, the camera can be turned left or right up to 12° off center for fine-tuning adjustments. The 3.6mm wide angle lens provides a wide field of view. The unit operates on 12VDC and consumes a total of 1.1 Watts

Specifications



Part Number	SCICH36-B
Camera Type	Color Hi-Res
Image Sensor	1/3" Sony Super HAD CCD
Signal System	NTSC
Effective Pixels	768 (H) x 494 (V)
Resolution	540TVL
Minimum Illumin	0.1Lux/F1.2
Dynamic Range	n/a
S/N Ratio	>48dB
Control Method	n/a
Electronic Shutter	1/60 - 1/100,000 sec
White Balance	Auto
AGC	Auto
BLC	Auto
Gamma Correction	0.45
Lens	3.6 mm
Power Supply	12VDC
Power Consumption	0.93 mA
Operating Temperature	-10°C ~ +50°C (+14°F ~ +122°F), 90% RH Max

DIMENSIONAL OUTLINES

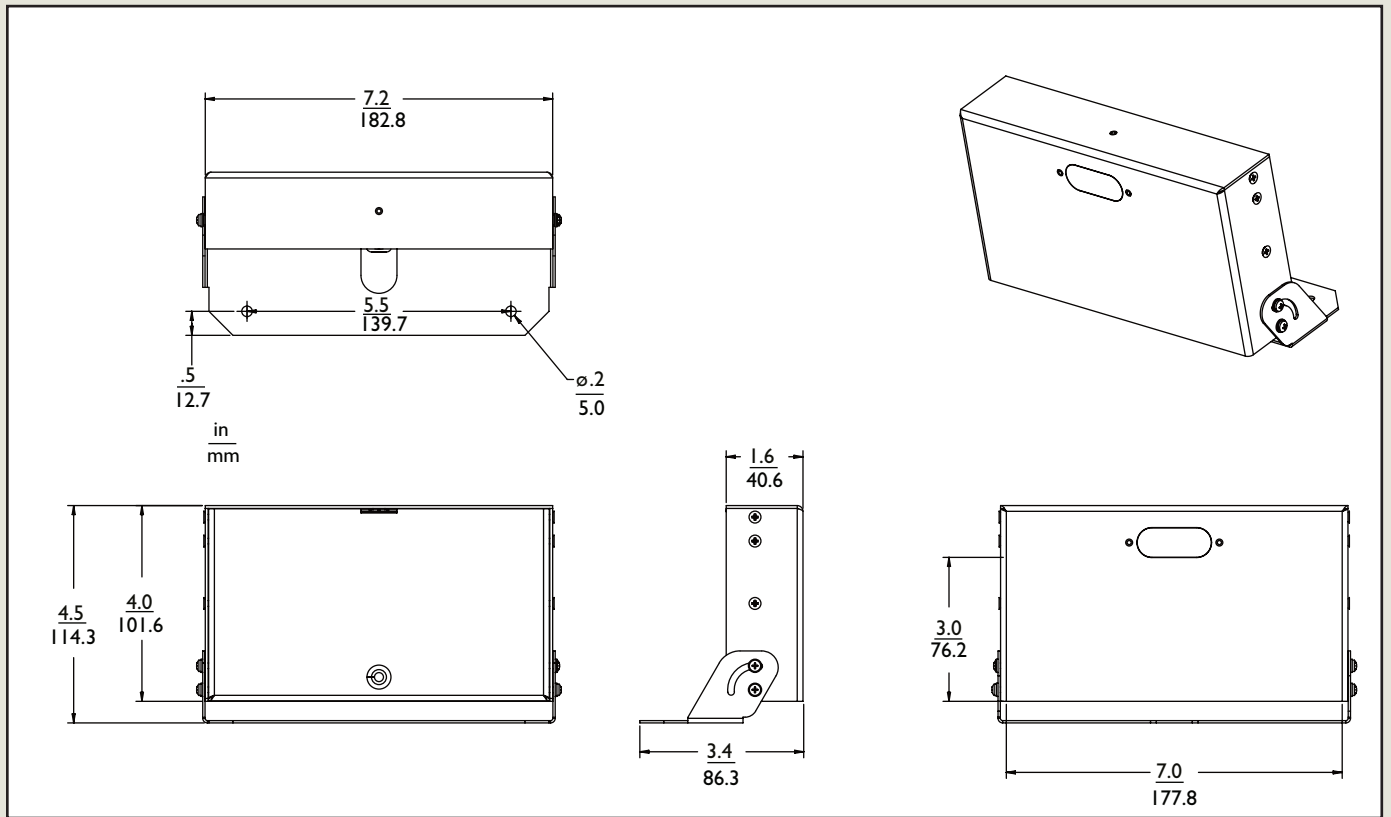

1950 Camino Vida Roble, Suite 150
 Carlsbad, CA 92008
 Tel: 760.438.7000 800.421.1587
 www.aigismech.com • www.linearcorp.com