

High Production Dual Input Cornerless Spreader Feeder

EDGE ULTRAMAXX™



The Ultimate Combination of Quality, Speed and Ergonomics Featuring the Proven and Patented Edge Technology Used in Thousands of Laundries Every Day

Ultra Maxx is the new high production cornerless spreader feeder designed to keep up with the very fastest operators and ironers processing large linen items of any size – including king size sheets. Chicago's unique and patented cornerless rapid dual input system is ergonomically correct and allows more throughput of sheets per hour with fewer operators than any other system. Ultra Maxx is designed to amplify the productivity of laundry personnel by using comfortable, yet space efficient, lateral separation of the fast moving input conveyors. Each operator effectively has their own machine to work with. Faster speed capability and 50% more storage capacity allow even the best operator to have fewer limitations and zero wait time.

Powerful vacuum laydown ensures a superior finish on everything from king size sheets to table linen. The system is controlled by Chicago's unique CHI•Touch PC control to squeeze every ounce of production and reliability out of the equipment. Ergonomic design means employees can work quickly without the strain normally placed on operators who have to work on a clip-type feeder of older design. An operator only has to lay one edge of a sheet onto one of the dual input conveyors. The sheet does not have to be placed square, straight, or centered because Ultra Maxx does the rest of the work by automatically finding corners as it locates, centers, and straightens the sheet's leading edge for spreading by servo motor/timing belt drive and vacuum laydown on both feeding and trailing edges. By not requiring manual location and loading of one or more sheet corners, Ultra Maxx provides high volume feeding with substantially reduced FTE hours by eliminating one or more operators compared to other high speed automated feeding methods.

Ultra Maxx

Dimensions and Utilities

CONNECTIONS	DIA.	HEIGHT
A Air Connection	1/2"	14" [355]
E Electrical Connection	--	78" [1990]

NOTE:

1. Specifications subject to change without notice. Consult factory for certified construction floorplan.
2. Millimeter dimensions are in [].
3. All dimensions are +/- 1/2".
4. Utility connections are located at rear.

Side View

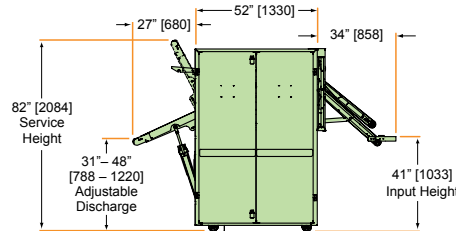

Top View

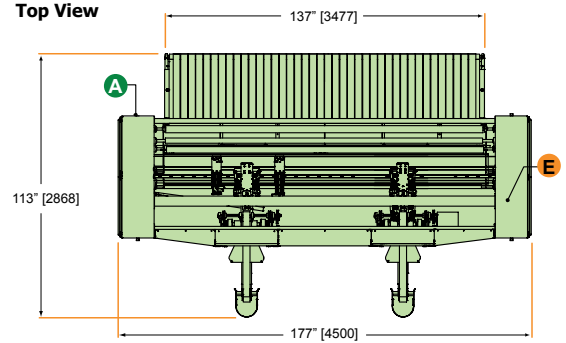

Front View

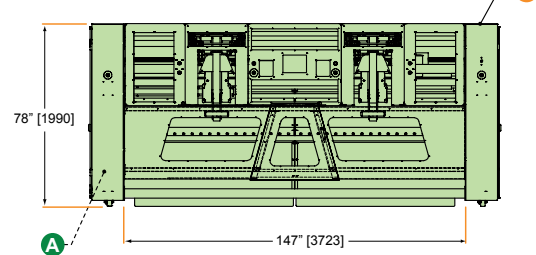

Features

Edge Technology Proven in Thousands of Laundries

- Patented high speed dual input cornerless feeding
- Handles any size large item including king and queen size sheets
- State-of-the-art Chi•Touch PC control
- The best of both worlds—two operators can produce as much linen every hour as the fastest available four station feeder that requires four or more operators to do the same work
- Powerful vacuum leading and trailing edge laydown for excellent quality
- Effortless operation reduces operator stress and repetitive body motions to keep production high
- Variable speed range of 20 to 160 FPM
- Available in 120" (3050mm) or 136" (3450mm) workable widths
- Automatic advancement of linen to upper spreading platform allows extended operator viewing time of items for stain/tear grading
- Optional Chicago Automatic Reject Processor stain/tear reject system buttons
- Automatic piece counters for each loading station provide accurate production numbers for each operator.
- Can also be operated efficiently with just one operator during off peak demand periods

New, High-Tech CHI•Touch Screen



The new **Chicago High Intelligence (CHI) Touch** PC-based control screen, with enhanced graphical user interface, gives the operator and supervisor more information at their fingertips with easier visual prompts, and greater flexibility than ever before. With the touch of the screen (eliminating the old style of key coding), the user can access program details, and view dynamic 3-D graphics to help quickly set up and begin their assignment. CHI•Touch is the industry's most intuitive, visually interactive, and user-friendly control screen.



A Complete Range of Separating, Feeding, Ironing, Folding, and Sorting Options

Because Chicago specializes only in flatwork finishing equipment, it can offer the world's widest range of high production separating, feeding, ironing, folding and sorting equipment. Complete flatwork finishing systems range from automated multi-roll systems producing over 2000 pounds per hour, to compact ironers for small on-premise laundries.

Chicago's performance record is unmatched in thousands of installations in commercial, hospitality, health care, textile rental, institutional and on-premise laundries all over the world. An experienced Chicago professional will be pleased

to make an objective equipment recommendation based on your production, space, utility and budget requirements. Contact your local Chicago distributor or the factory sales assistance office for a no-obligation analysis of your needs.

Chicago's Customer Service department offers full technical and service support by telephone and on our website. We also offer overnight service for quick parts availability. Visit our website, www.chidry.com, to learn more about our complete line of flatwork finishing systems, including video of Chicago® equipment in action.



CHICAGO DRYER COMPANY
2200 North Pulaski Road
Chicago, Illinois 60639-3737 USA

Phone • 773.235.4430
Fax • 773.235.4439
Web • www.chidry.com
Email • chicago@chidry.com