

Small Piece Folder that Sorts and Folds

Air Chicago Quattro

CHICAGO[®]



Introducing



Triple Sorting Flexibility

For laundries that desire automatic post-sorting ability, Air Chicago Quattro combines the convenience of automatic three-way sorting, folding, crossfolding, and stacking with the folding accuracy, speed, and dependability for which the Air Chicago Series is well-known. Air Chicago Quattro enables an operator to randomly feed up to three different size towels or gowns for folding. As items are loaded, the folder's input ramp can pause briefly (without interrupting other folding and conveyor functions), before **CHI** advances the item to the automatically adjustable folding bed for a crisp and accurate French fold. **CHI•Touch** PC Control automatically determines the item type, chooses and performs the correct fold pattern, and directs the folded item to one of three internal drop zones for stacking with like items in pre-selected stack heights. (Consult factory for stack size limitations.)

After each stack is completed, it is advanced to an attached discharge conveyor set up to deliver completed stacks to the front or rear of unit at the left or right side. An optional second discharge conveyor can be added to allow two-way work flow to front or rear.

Air Chicago Quattro

Dimensions and Utilities

NOTE:

1. Specifications subject to change without notice. Consult factory for certified construction floorplan.
2. Millimeter dimensions are in [].
3. All dimensions are +/- 1/2".
4. Utility connections are located as shown.

CONNECTION(S)	DIA.	HEIGHT
(A) Air Connection	1/2"	29-1/2" [749]
(D) Compressed Air Drain	1/4"	23" [584]
(E) Electrical Connection	-	31" [787]

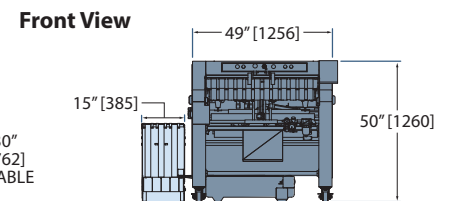
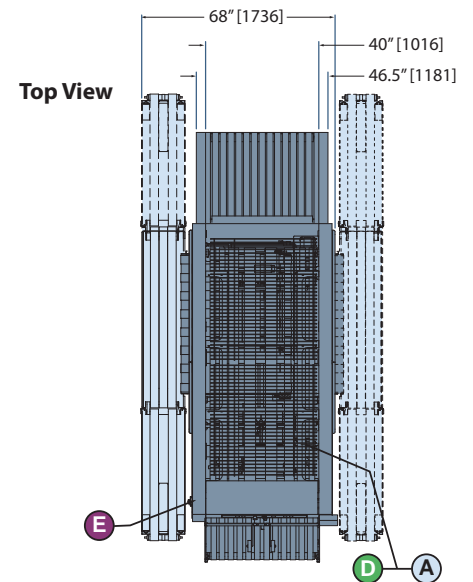
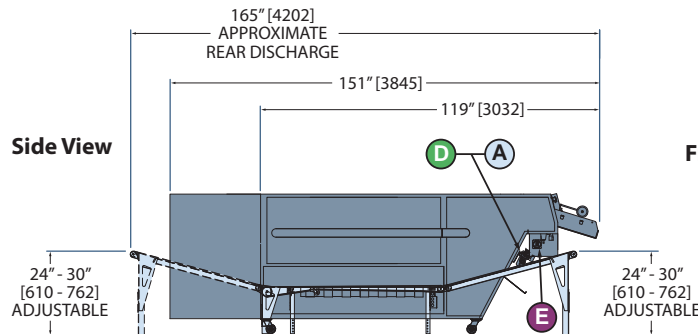

Reversing Conveyors

More Speed When You Need It

When auto sorting is not required because only one size is being processed, Air Chicago Quattro may be operated in a continuously running "non sort" mode (like a standard Air Chicago) to maximize speed and output. Most importantly, items are accurately folded to the precise tolerances that have made Air Chicago the industry standard by which all towel and gown folders are judged.

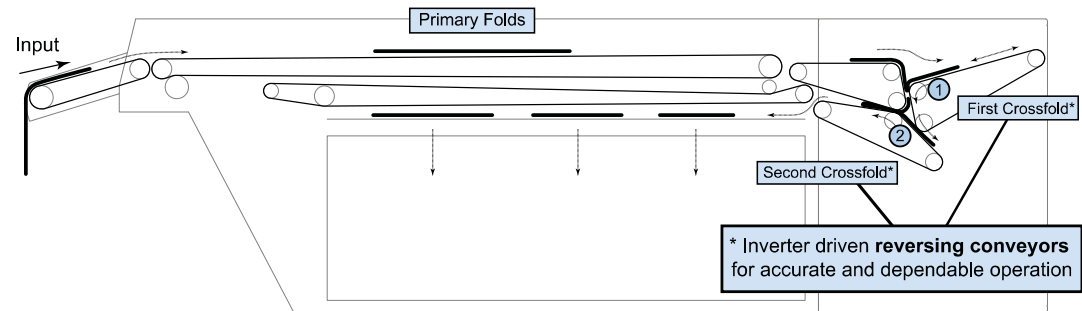

A Complete Range of Separating, Feeding, Ironing, Folding, and Sorting Options

Because Chicago specializes only in flatwork finishing equipment, it can offer the world's widest range of high production separating, feeding, ironing, folding and sorting equipment. Complete flatwork finishing systems range from automated multi-roll systems producing over 2000 pounds per hour, to compact ironers for small on-premise laundries.

Chicago's performance record is unmatched in thousands of installations in commercial, hospitality, health care, textile rental, institutional and on-premise laundries all over the world. An experienced Chicago professional will be pleased to make an objective

equipment recommendation based on your production, space, utility and budget requirements. Contact your local Chicago distributor or the factory sales assistance office for a no-obligation analysis of your needs.

Chicago's Customer Service department offers full technical and service support by telephone and on our website. We also offer overnight service for quick parts availability. Visit our website, www.chidry.com, to learn more about our complete line of flatwork finishing systems, including video of Chicago® equipment in action.



CHICAGO DRYER COMPANY
2200 North Pulaski Road
Chicago, Illinois 60639-3737 USA

Phone • 773.235.4430
Fax • 773.235.4439
Web • www.chidry.com
Email • chicago@chidry.com