

VDA80TVI

Full HD IR Outdoor Vandalproof Dome Camera



Key Features

- * HD video transmission up to 500M by Coaxial cable (Up to 300M by UTP)
- * No additional installation cost.
(Compatible with existing coaxial cables)
- * 1920X1080 25p/30p, 1280X720 50p/60p
- * Enhanced WDR performance
- * Quick and easy OSD control
- * 2D/3D DNR (Digital Noise Reduction)
- * Defog function
- * Dynamic digital zoom and PIP
- * Intelligent IR ,Smart IR
- * Pelco-C support
- * Privacy Masking (8 Polygon Area)
- * Supports 15 Languages
- * 12VDC

Dimensions

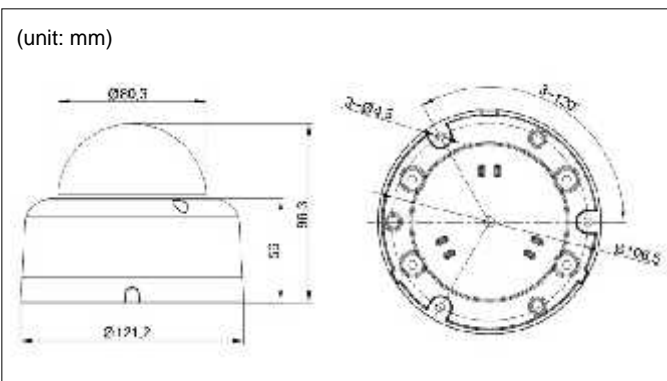

Specifications

MODEL	VDA80FTV-VIR
Sensor Device	1/2.9 inch 2.38MP CMOS Sensor
Total Pixels	2000(H) x1241(V) 2.48 Megapixel
Effective Pixels	1984(H) x1105(V) 2.19 MP
Scanning System	Progressive Scan
Horizontal	More than 1100 TVL
S/N Ratio	More than 52dB(AGC Off)
Min. Illumination	0 Lux (IR On)
Shutter Speed	1/30s Default,(Long Exposure Mode, ~1Sec)
Video Output	1920 x 1080 @25p/30P 1280 x 720 @50p/60P (Mode Select)
Video Output Format	TVI Output, 1Port CVBS
CVBS Output	1V p-p Composite. 75 Ohms
Digital Output	TVI Output
Day & Night	True Day & Night with ICR
Serial Port	Pelco-C support analog video only
Lens	2.8-11mm 3Mega Pixel VF DC Iris Lens 4mm/6mm(Optional)
Lens Control	DC Iris
IR Distance	20m
Power Source	DC12V Only
Operating Current	180mA (IR Off), 350mA (IR On)
Operating Temperature	-10°C ~ 50°C
Storage Temperature	-20C ~ 60C
Operating Humidity	(Humidity : 0%RH ~ 90%RH)
Measurement (mm)	121.2() x 96.3(H)
Weight (Approx.)	570g Appr.(Camera Only)
OSD	Video Mode / D&N / AWB / AE /Privacy Mask / Flickerless / Brightness / Sharpness / Mirror & Flip / DSS/DNR, etc.

*specifications are subject to change without prior notice for improvement.