

REGULATORS

B Series

Pressure Regulating Valve

Watson McDaniel reserves the right to change the designs and/or materials of its products without notice.
©2010 Watson McDaniel Company

DIRECT-OPERATED REGULATING VALVES

Model	B Series
Service	Water, Air, Oil, Other Gases & Liquids
Sizes	1/2", 3/4", 1", 1 1/4", 1 1/2", 2", 2 1/2", 3", 4"
Connections	NPT, 125# & 250# Flanged
Body Material	1/2"– 2 1/2" Bronze 3" & 4" Cast Iron
Disc	Neoprene (standard) - 200°F max Viton (optional) - 300°F max
Diaphragm	Neoprene/Nylon - 200°F max Viton (optional) - 300°F max
Max. Inlet Pressure	250 PSIG
Min. Inlet Pressure	10 PSIG
Max. Diff. Pressure	125 PSI
Min. Diff. Pressure	20% of Inlet Pressure

DESIGN PRESSURE/TEMPERATURE RATING – PMA/TMA

NPT	250 PSIG @ 400°F
125# FLG	125 PSIG @ 450°F
250# FLG	250 PSIG @ 450°F

TYPICAL APPLICATION

The **B Series** Pressure Regulating Valves are used for reducing pressure in air and water systems. These regulators are commonly found in industrial plants, apartment buildings, water supply systems, schools and underground water distribution systems.

FEATURES & OPTIONS

- Diaphragm, disc and cup packing available in Viton for 300°F service (optional)
- Balanced pressure regulator allows accurate control even when incoming pressure fluctuates
- Internally senses pressure – no external sensing line required
- Soft disc in Neoprene or Viton for Class-V shut-off rating

HOW TO SIZE/ORDER

From the Capacity chart, find the inlet pressure and required regulator outlet pressure. Follow across chart to nearest capacity of application service medium that meets or slightly exceeds demand requirements. Follow vertically up to determine appropriate size. When exact application values are not shown, interpolation between values is acceptable. From the Spring Ranges chart, select the ideal spring range that accommodates the required outlet set pressure. Confirm that system pressure requirements can be accommodated by valve. Example:

Application: 35 GPM of 70 PSIG Water reduced to 20 PSIG
Size/Model: 1" B-Series, 5-35 PSIG spring range



PRESSURE-ADJUSTING SPRING RANGES

Outlet Pressure (PSIG)	Spring No.
1-12	4*
5-35	3
20-70	2
40-125	1

* 1/2" – 1" only

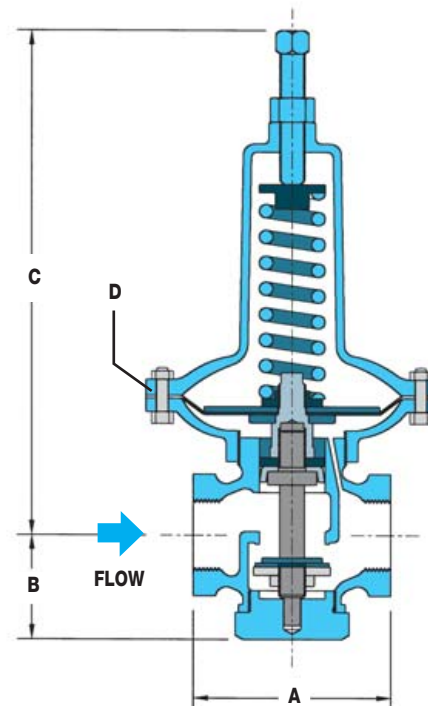

REGULATORS

B Series

Pressure Regulating Valves

DIMENSIONS & WEIGHTS – inches/pounds

Size	Face-to-Face A			B	C	D Spring Case Dia. (in.)	Weight (lbs)
	NPT Threaded	125# Flanged	250# Flanged				
1/2", 3/4"	3 ³ / ₈			1 ⁷ / ₈	9	5	7
1"	3 ⁵ / ₈			2 ¹ / ₄	9 ¹ / ₂	5	8
1 ¹ / ₄ "	4 ¹ / ₄			2 ³ / ₈	10 ¹ / ₂	6 ³ / ₄	13
1 ¹ / ₂ "	4 ³ / ₄			2 ¹ / ₂	10 ³ / ₄	6 ³ / ₄	15
2"	5 ⁷ / ₈			3 ³ / ₈	11 ⁵ / ₈	6 ³ / ₄	20
2 ¹ / ₂ "	6 ¹ / ₂			4 ¹ / ₄	12 ³ / ₄	6 ³ / ₄	30
3"		10 ¹ / ₄	11	4 ¹ / ₂	21 ¹ / ₂	9 ¹ / ₄	125
4"		13	13 ⁵ / ₈	5 ³ / ₄	23	9 ¹ / ₄	182

DIRECT-OPERATED
REGULATING VALVES

CAPACITIES – Water (GPM); Air (SCFM)

Inlet/Outlet Pressures (PSIG)

Inlet Press.	Outlet Press.	1/2"		3/4"		1"		1 ¹ / ₄ "		1 ¹ / ₂ "		2"		2 ¹ / ₂ "		3"		4"	
		Water	Air	Water	Air	Water	Air	Water	Air	Water	Air	Water	Air	Water	Air	Water	Air	Water	Air
10	5	5.5	25	10	45	13	60	22	100	33	150	55	250	88	400	132	600	176	800
	20	9.8	48	18	86	23	114	39	190	59	285	98	475	156	760	234	1140	312	1520
20	10	8.0	43	14	77	19	102	32	170	48	255	80	425	128	680	192	1020	256	1360
	15	5.5	30	10	54	13	72	22	120	33	180	55	300	88	480	132	720	176	960
30	5	12.5	68	23	122	30	162	50	270	75	405	125	675	200	1080	300	1620	400	2160
	10	11.3	63	20	113	27	150	45	250	68	375	113	625	180	1000	270	1500	360	2000
50	20	8.0	48	14	86	19	114	32	190	48	285	80	475	128	760	192	1140	256	1520
	5	16.8	98	30	176	40	234	67	390	101	585	168	975	268	1560	402	2340	536	3120
50	25	12.5	88	23	158	30	210	50	350	75	525	125	875	200	1400	300	2100	400	2800
	40	8.0	63	14	113	19	150	32	250	48	375	80	625	128	1000	192	1500	256	2000
70	10	19.3	128	35	230	46	306	77	510	116	765	193	1275	308	2040	462	3060	616	4080
	30	15.8	125	28	225	38	300	63	500	95	750	158	1250	252	2000	378	3000	504	4000
100	50	11.3	95	20	171	27	228	45	380	68	570	113	950	180	1520	270	2280	360	3040
	30	21.0	175	38	315	50	420	84	700	126	1050	210	1750	336	2800	504	4200	672	5600
100	50	17.5	165	32	297	42	396	70	660	105	990	175	1650	280	2640	420	3960	560	5280
	70	13.8	135	25	243	33	324	55	540	83	810	138	1350	220	2160	330	3240	440	4320
125	30	24.3	213	44	383	58	510	97	850	146	1275	243	2125	388	3400	582	5100	776	6800
	50	21.5	213	39	383	52	510	86	850	129	1275	215	2125	344	3400	516	5100	688	6800
150	100	12.5	140	23	252	30	336	50	560	75	840	125	1400	200	2240	300	3360	400	4480
	30	27.5	250	50	450	66	600	110	1000	165	1500	275	2500	440	4000	660	6000	880	8000
150	50	25.0	250	45	450	60	600	100	1000	150	1500	250	2500	400	4000	600	6000	800	8000
	100	17.5	205	32	369	42	492	70	820	105	1230	175	2050	280	3280	420	4920	560	6560
200	125	12.5	153	23	275	30	366	50	610	75	915	125	1525	200	2440	3000	3660	400	4880
	70	28.5	325	51	585	68	780	114	1300	171	1950	285	3250	456	5200	684	7800	912	10400
250	100	25.0	263	45	473	60	630	100	1050	150	1575	250	2625	400	4200	600	6300	800	8400
	125	21.5	223	39	401	52	534	86	890	129	1335	215	2225	344	3560	516	5340	688	7120
250	100	30.8	403	55	725	74	966	123	1610	185	2415	308	4025	492	6440	738	9660	984	12880
	125	28.0	393	50	707	67	942	101	1570	168	2355	280	3925	448	6280	672	9420	896	12560

Note: For capacities of other gases multiply the air capacities by the following factors: Argon-0.85 CO₂-0.81 Helium-2.69 Nitrogen-1.0